

Service Manual

Compact Plain Paper Fax (with Digital Answering System)

KX-FP207FX-S

KX-FP218FX-S

(for Eastern Europe)

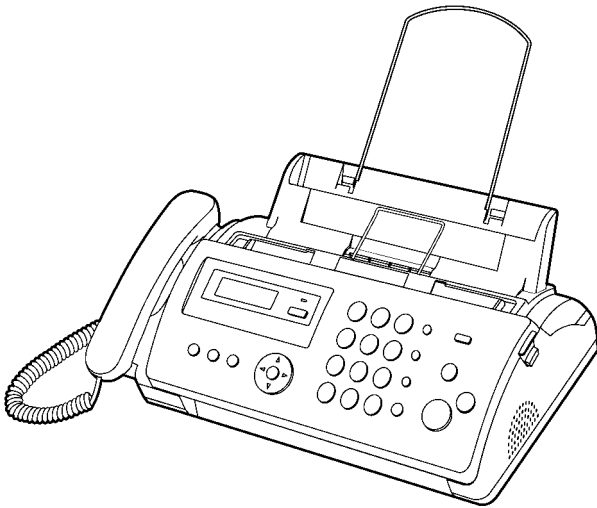

This pictured model is KX-FP207.

WARNING

This service information is designed for experienced repair technicians only and is not designed for use by the general public. It does not contain warnings or cautions to advise non-technical individuals of potential dangers in attempting to service a product. Products powered by electricity should be serviced or repaired only by experienced professional technicians. Any attempt to service or repair the product or products dealt with in this service information by anyone else could result in serious injury or death.

IMPORTANT SAFETY NOTICE

There are special components used in this equipment which are important for safety. These parts are marked by  in the Schematic Diagrams, Circuit Board Diagrams, Exploded Views and Replacements Parts List. It is essential that these critical parts should be replaced with manufacturer's specified parts to prevent shock, fire or other hazards. Do not modify the original design without permission of manufacturer.

IMPORTANT INFORMATION ABOUT LEAD FREE, (PbF), SOLDERING

If lead free solder was used in the manufacture of this product the printed circuit boards will be marked PbF. Standard leaded, (Pb), solder can be used as usual on boards without the PbF mark.

When this mark does appear please read and follow the special instructions described in this manual on the use of PbF and how it might be permissible to use Pb solder during service and repair work.

When you note the serial number, write down all 11 digits. The serial number may be found on the bottom of the unit.

Panasonic®

© 2006 Panasonic Communications Co., Ltd.
All rights reserved. Unauthorized copying and distribution is a violation of law.

TABLE OF CONTENTS

	PAGE		PAGE
1 Safety Precaution -----	3	15.1. Maintenance Items and Component Locations -	163
1.1. For Service Technicians-----	3	15.2. Gear Section-----	165
1.2. AC Caution-----	3	15.3. Jams-----	172
1.3. Personal Safety Precautions-----	4	15.4. Cleaning-----	174
1.4. Service Precautions-----	5	16 Miscellaneous -----	176
2 Warning -----	6	16.1. Terminal Guide of the ICs Transistors and	
2.1. About Lead Free Solder (PbF: Pb free)-----	6	Diodes-----	176
2.2. Insulation Resistance Test-----	7	16.2. How to Replace the Flat Package IC-----	178
2.3. Battery Caution-----	7	16.3. Test Chart-----	180
2.4. Disposal Cautions-----	7	17 Schematic Diagram -----	183
3 Specifications -----	8	17.1. Digital Board (PCB1) (KX-FP207FX)-----	183
4 General/Introduction -----	9	17.2. Digital Board (PCB1) (KX-FP218FX)-----	187
4.1. Optional Accessories-----	9	17.3. Analog Board (PCB2) (KX-FP207FX)-----	191
5 Features -----	9	17.4. Analog board (PCB2) (KX-FP218FX)-----	193
6 Technical Descriptions -----	10	17.5. Operation Board (PCB3) (KX-FP207FX)-----	195
6.1. Connection Diagram-----	10	17.6. Operation Board (PCB3) (KX-FP218FX)-----	196
6.2. General Block Diagram-----	11	17.7. Power Supply Board (PCB4)-----	197
6.3. Control Section-----	13	17.8. Interface Board (PCB5)-----	198
6.4. Facsimile Section-----	22	17.9. Sensor Board (PCB6)-----	199
6.5. Sensors and Switches-----	29	17.10. Film End SensorBoard (PCB7)-----	199
6.6. Modem Section-----	33	17.11. Motor Position Sensor Board (PCB8)-----	199
6.7. NCU Section-----	40	17.12. Hook Switch Board (PCB9)-----	200
6.8. ITS (Integrated telephone System) and		18 Printed Circuit Board -----	202
Monitor Section-----	43	18.1. Digital Board (PCB1)-----	202
6.9. Operation Board Section-----	45	18.2. Analog Board (PCB2)-----	204
6.10. LCD Section-----	46	18.3. Operation Board (PCB3)-----	206
6.11. Power Supply Board Section-----	47	18.4. Power Supply Board (PCB4)-----	208
7 Location of Controls and Components -----	50	18.5. Interface Board (PCB5)-----	209
7.1. Overview-----	50	18.6. Sensor Board (PCB6)-----	209
7.2. Control Panel-----	50	18.7. Film End Sensor Board (PCB7)-----	209
8 Installation Instructions -----	51	18.8. Motor Position Sensor Board (PCB8)-----	209
8.1. Installation Space-----	51	18.9. Hook Switch Board (PCB9)-----	210
8.2. Connections-----	52	19 Appendix Information of Schematic Diagram -----	210
8.3. Installing the Ink Film-----	53	20 Exploded View and Replacement Parts List -----	211
8.4. Installing the Paper Tray-----	54	20.1. Cabinet, Mechanical and Electrical Parts	
8.5. Paper Support-----	55	Location-----	211
8.6. Installing the Recording Paper-----	55	20.2. Replacement Parts List-----	221
9 Operation Instructions -----	56		
9.1. Setting Your Logo-----	56		
10 Test Mode -----	58		
10.1. DTMF Signal Tone Transmit Selection-----	59		
10.2. Button Code Table-----	60		
10.3. Print Test Pattern-----	61		
11 Service Mode -----	62		
11.1. Programing and Lists-----	62		
11.2. The Example of the Printed List-----	67		
12 Troubleshooting Guide -----	72		
12.1. Troubleshooting Summary-----	72		
12.2. Error Messages-Display-----	73		
12.3. Error Messages-Report-----	75		
12.4. Remote Programming-----	97		
12.5. Troubleshooting Details-----	100		
13 Service Fixture & Tools -----	136		
14 Disassembly and Assembly Instructions -----	137		
14.1. General Section-----	137		
14.2. Disassembly Flowchart-----	138		
14.3. Disassembly Procedure-----	140		
15 Maintenance -----	163		

1 Safety Precaution

1. Before servicing, unplug the AC power cord to prevent an electric shock.
2. When replacing parts, use only the manufacturer's recommended components.
3. Check the condition of the power cord. Replace if wear or damage is evident.
4. After servicing, be sure to restore the lead dress, insulation barriers, insulation papers, shields, etc.
5. Before returning the serviced equipment to the customer, be sure to perform the following insulation resistance test to prevent the customer from being exposed to shock hazards.

1.1. For Service Technicians

ICs and LSIs are vulnerable to static electricity.

When repairing, the following precautions will help prevent recurring malfunctions.

1. Cover the plastic part's boxes with aluminum foil.
2. Ground the soldering irons.
3. Use a conductive mat on the worktable.
4. Do not touch the IC or LSI pins with bare fingers.

1.2. AC Caution

For safety, before closing the lower cabinet, please make sure of the following precautions.

1. The earth lead is fixed with the screw.
2. The AC lead is connected properly to power supply board.
3. Wrap the earth lead around the core 5 times.
4. Wrap the AC lead around the core 5 times.

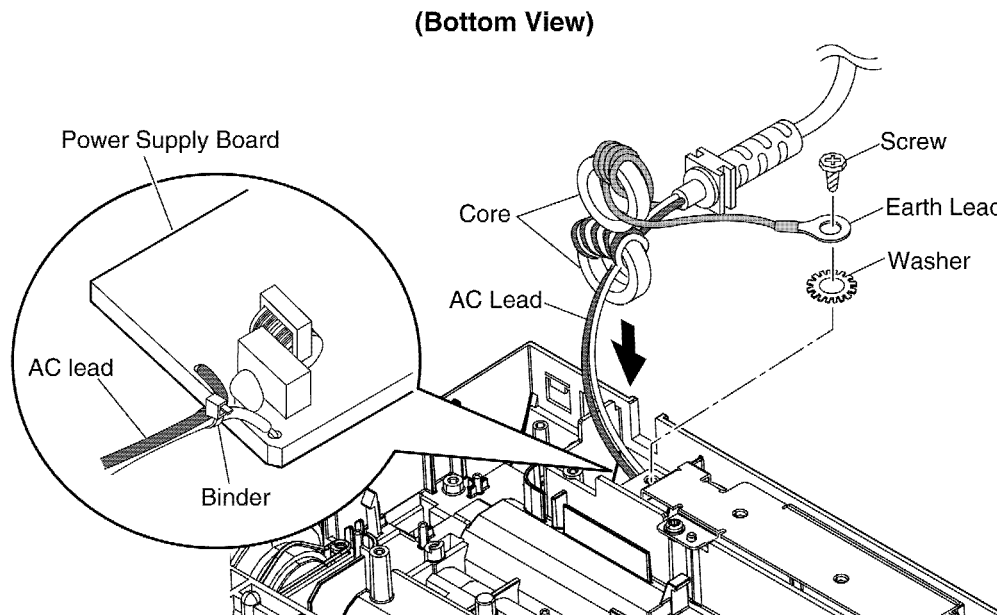

1.3. Personal Safety Precautions

1.3.1. Moving Sections of the Unit

Be careful not to let your hair, clothes, fingers, accessories, etc., become caught in any moving sections of the unit. The moving sections of the unit are the rollers and a gear. There is a separation roller and a document feed roller which are rotated by the document feed motor. A gear rotates the two rollers. Be careful not to touch them with your hands, especially when the unit is operating.

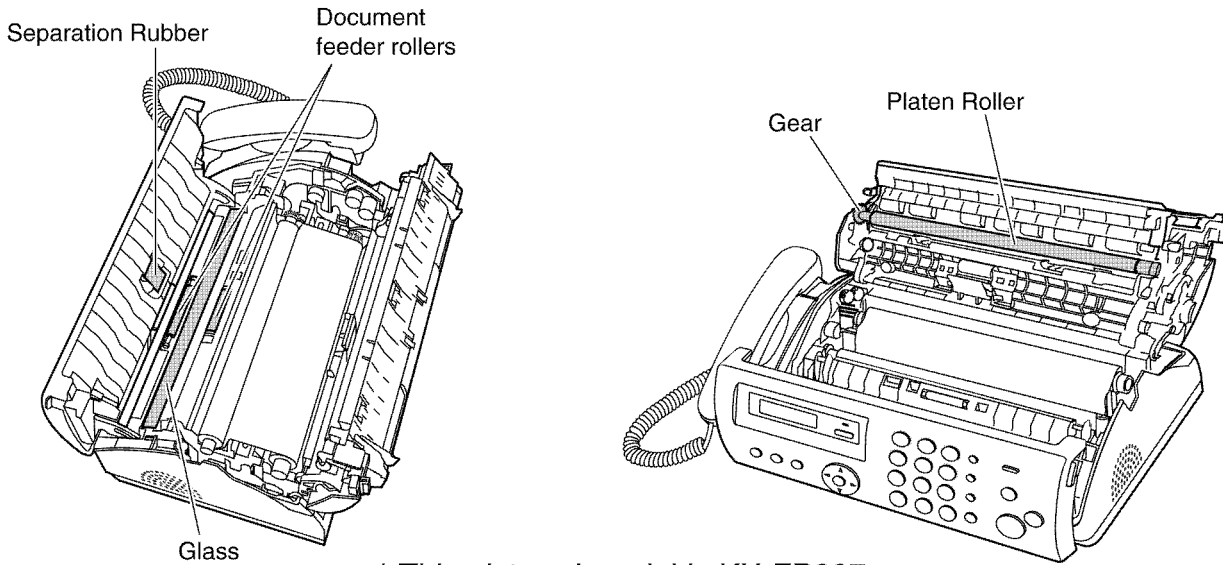

* This pictured model is KX-FP207.

1.3.2. Live Electrical Sections

All the electrical sections of the unit supplied with AC power by the AC power cord are live. Never disassemble the unit for service with the AC power supply plugged in.

CAUTION:

AC voltage is supplied to the primary side of the power supply unit. Therefore, always unplug the AC power cord before disassembling for service.

(Bottom View)

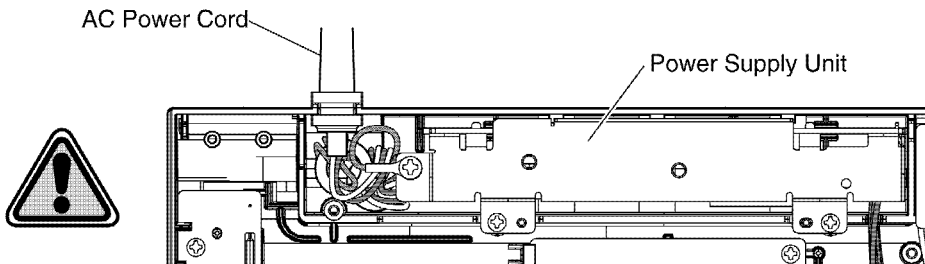

1.4. Service Precautions

1.4.1. Precautions to Prevent Damage from static Electricity

Electrical charges accumulate on a person. For instance, clothes rubbing together can damage electric elements or change their electrical characteristics. In order to prevent static electricity, touch a metallic part that is grounded to release the static electricity. Never touch the electrical sections such as the power supply unit, etc.

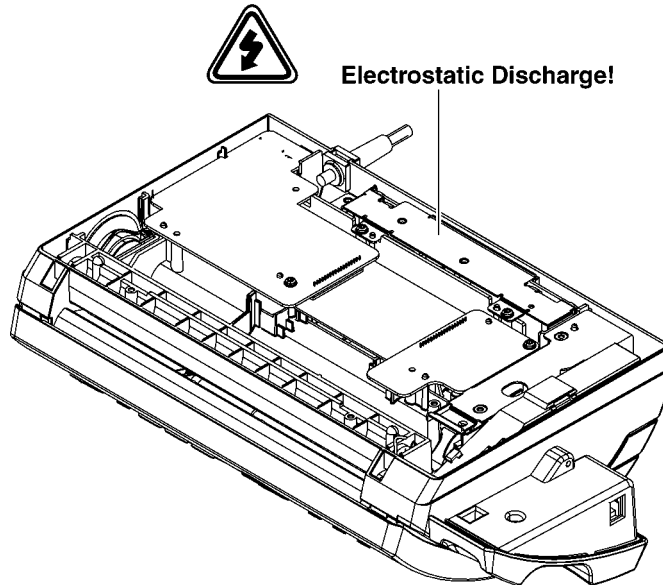

2 Warning

2.1. About Lead Free Solder (PbF: Pb free)

Note:

In the information below, Pb, the symbol for lead in the periodic table of elements, will refer to standard solder or solder that contains lead.

We will use PbF solder when discussing the lead free solder used in our manufacturing process which is made from Tin, (Sn), Silver, (Ag), and Copper, (Cu).

This model, and others like it, manufactured using lead free solder will have PbF stamped on the PCB. For service and repair work we suggest using the same type of solder.

Caution

- PbF solder has a melting point that is 50° ~ 70° F, (30° ~ 40°C) higher than Pb solder. Please use a soldering iron with temperature control and adjust it to 700° ± 20° F, (370° ± 10°C).
- Exercise care while using higher temperature soldering irons.: Do not heat the PCB for too long time in order to prevent solder splash or damage to the PCB.
- PbF solder will tend to splash if it is heated much higher than its melting point, approximately 1100°F, (600°C).
- When applying PbF solder to double layered boards, please check the component side for excess which may flow onto the opposite side (See figure, below).

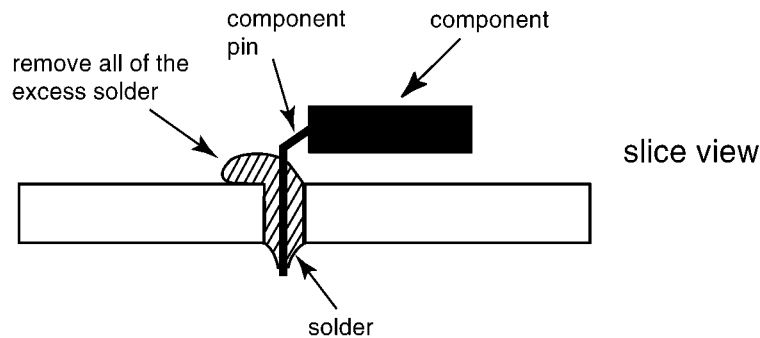

2.1.1. Suggested PbF Solder

There are several types of PbF solder available commercially. While this product is manufactured using Tin, Silver, and Copper, (Sn+Ag+Cu), you can also use Tin and Copper, (Sn+Cu), or Tin, Zinc, and Bismuth, (Sn+Zn+Bi). Please check the manufacturer's specific instructions for the melting points of their products and any precautions for using their product with other materials.

The following lead free (PbF) solder wire sizes are recommended for service of this product: 0.3mm, 0.6mm and 1.0mm.

0.3mm X 100g	0.6mm X 100g	1.0mm X 100g

2.2. Insulation Resistance Test

1. Unplug the power cord and short the two prongs of the plug with a jumper wire.
2. Turn on the power switch.
3. Measure the resistance value with an ohmmeter between the jumpered AC plug and each exposed metal cabinet part (screw heads, control shafts, bottom frame, etc.).

Note: Some exposed parts may be isolated from the chassis by design. These will read infinity.

4. If the measurement is outside the specified limits, there is a possibility of a shock hazard.

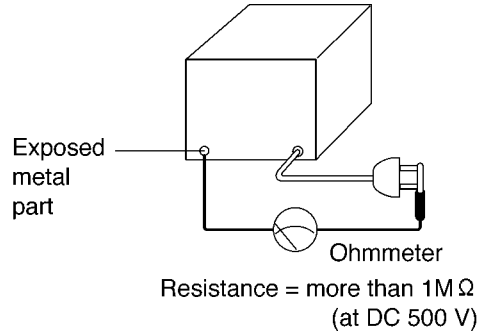

2.3. Battery Caution

Danger of explosion if battery is incorrectly replaced. Replace only with the same or equivalent type recommended by the manufacturer. Dispose of used batteries according to the manufacturer's instruction.

CAUTION:

The lithium battery is a critical component (type No. CR2032). Please observe for the proper polarity and the exact location when replacing it and soldering the replacement lithium battery in.

2.4. Disposal Cautions

2.4.1. Information on Disposal for Users of Waste Electrical & Electronic Equipment (private households)

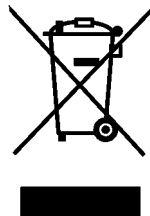

This symbol on the products and/or accompanying documents means that used electrical and electronic products should not be mixed with general household waste.

For proper treatment, recovery and recycling, please take these products to designated collection points, where they will be accepted on a free of charge basis. Alternatively, in some countries you may be able to return your products to your local retailer upon the purchase of an equivalent new product.

Disposing of this product correctly will help to save valuable resources and prevent any potential negative effects on human health and the environment which could otherwise arise from inappropriate waste handling. Please contact your local authority for further details of your nearest designated collection point. Penalties may be applicable for incorrect disposal of this waste, in accordance with national legislation.

For business users in the European Union

If you wish to discard electrical and electronic equipment, please contact your dealer or supplier for further information.

Information on Disposal in other Countries outside the European Union

This symbol is only valid in the European Union.

If you wish to discard this product, please contact your local authorities or dealer and ask for the correct method of disposal.

3 Specifications

Any details given in these instructions are subject to change without notice.

Applicable Lines:	Public Switched Telephone Network
Document Size:	Max. 216 mm in width, Max. 600 mm in length
Effective Scanning Width:	208 mm
Recording Paper Size:	A4: 210 mm × 297 mm
Effective Printing Width:	A4: 202 mm
Recording Paper Weight:	64 g/m ² to 80 g/m ²
Transmission Speed*¹ (KX-FP207):	Approx. 12 s/page (ECM-MMR)* ²
Transmission Speed*¹ (KX-FP218):	Approx. 8 s/page (ECM-MMR)* ²
Scanning Density:	Horizontal: 8 pels/mm Vertical: 3.85 lines/mm (standard resolution) 7.7 lines/mm (fine/photo resolution) 15.4 lines/mm (super fine resolution)
Photo Resolution:	64 levels
Scanner Type:	Contact Image Sensor
Printer Type:	Thermal Transfer on Plain Paper
Data Compression System:	Modified Huffman (MH), Modified READ (MR), Modified Modified READ (MMR)
Modem Speed (KX-FP207):	9,600 / 7,200 / 4,800 / 2,400 bps; Automatic Fallback
Modem Speed (KX-FP218):	14,400 / 12,000 / 9,600 / 7,200 / 4,800 / 2,400 bps; Automatic Fallback
Operating Environment:	5—35°C, 20—80 % RH (Relative Humidity)
Dimensions:	Approx. height 106 mm × width 356 mm × depth 200 mm
Mass (Weight):	Approx. 2.7 kg
Power Consumption:	Standby: Approx. 1.5 W Transmission: Approx. 15 W Reception: Approx. 40 W (When receiving a 20% black document) Copy: Approx. 40 W (When copying a 20% black document) Maximum: Approx. 135 W (When copying a 100% black document)
Power Supply:	220 - 240 V AC, 50 / 60 Hz
Fax Memory Capacity*³:	Transmission: Approx. 25 pages Reception: Approx. 28 pages (Based on the ITU-T No. 1 Test Chart in standard resolution, without using the Error Correction Mode.)
Voice Memory Capacity*⁴ (KX-FP218):	Approx. 18 minutes of recording time including greeting messages

*¹ Transmission speed depends on the contents of the pages, resolution, telephone line conditions and capability of the other party's machine.

*² Transmission speed is based on the ITU-T No. 1 Test Chart with original mode. If the capability of the other party's machine is inferior to your unit, the transmission time may be longer. (Refer to **ITU-T No.1 Test chart** (P.180).)

*³ If an error occurs during fax reception, such as a paper jam or if the recording paper runs out, the fax and subsequent faxes will be retained in memory.

*⁴ Recording time may be reduced by the calling party's background noise.

4 General/Introduction

4.1. Optional Accessories

Model No.	Description	Specification
KX-FA52E	Replacement Film ^{*1}	30 m × 2 rolls (Each roll will print about 90 A4-sized pages)

^{*1} To ensure the unit operates properly, we recommend using the Panasonic replacement film.

The ink film is not reusable. Do not rewind and use the ink film again.

5 Features

General

- LCD (Liquid Crystal Display) readout

Plain Paper Facsimile Machine

- 12 second transmission speed (KX-FP207)*
- 8 second transmission speed (KX-FP218)**
- A4, G3 compatible
- Automatic document feeder (up to 10 sheets)
- Quick scan
- Resolution: Standard/Fine/Super fine/Photo (64 level)
- Broadcast
- 20-sheet recording paper capacity
- Automatic fax/phone switching

* The 12 second speed is based upon the ITU-T No. 1 Test Chart on the condition that memory transmission is performed.

** The 8 second speed is based upon the ITU-T No. 1 Test Chart on the condition that memory transmission is performed.

Large Memory... Performed by DRAM

Approx. 28 pages of memory reception

Approx. 25 pages of memory transmission

Integrated Telephone System

- On-hook dialling
- Voice muting
- Redialling function
- 50-station telephone directory with Phonebook
- Caller ID service

This unit is compatible with the Caller ID service offered by your local telephone company. To use this unit's Caller ID features, you must subscribe to Caller ID service.

Important:

- This unit is designed in accordance with the ETS (European Telecommunication Standard) and only supports the basic CLIP (Calling Line Identification Presentation) features.
- This unit will only display the caller's telephone number and name.
- This unit will not support future additional telephone services.
- Depending on the service of the local telephone company, the date/time of the call or the caller's name may not be displayed.

Make sure the following ring count is set to 2 or more rings beforehand.

- For KX-FP207: FAX ring count (feature #06 on P.98) and TEL/FAX ring count (feature #78 on P.98)

- For KX-FP218: TAM ring count (feature #06 on P.98) FAX ring count (feature #06 on P.98) and TEL/FAX ring count (feature #78 on P.98)

- SP-Phone, TAM (KX-FP218)

Enhanced Copier Function

- Multi-copy function (up to 20 copies)
- Enlargement and reduction
- Collate
- 64-Level halftone

6 Technical Descriptions

6.1. Connection Diagram

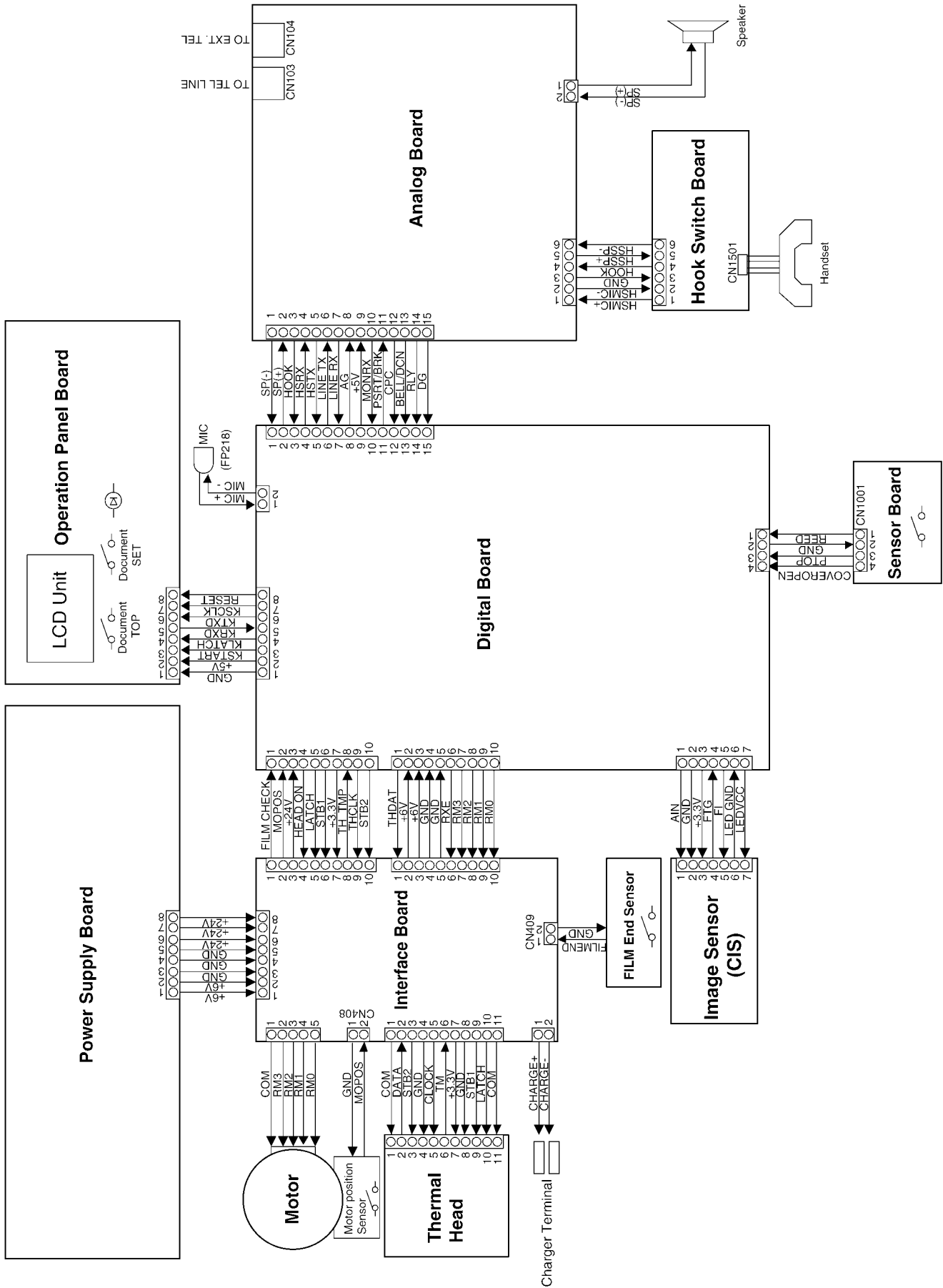

6.2. General Block Diagram

The following is an outline of each device IC on the digital board. (Refer to **General Block Diagram** (P.12)).

1. ASIC (IC501)
 - Composed mainly of an address decoder and a modem control.
 - Controls the general FAX operations.
 - Controls the operation panel I/F.
 - Controls the thermal head I/F and CIS I/F.
 - Performs the image processing.
 - CPU and Real time clock
 - Provides the reset pulse for each of the major ICs.
2. Flash ROM (IC506)
 - Contains all of the program instructions on the unit operations.
 - This memory is used mainly for the parameter working in the storage area.
3. Dynamic RAM (IC503)
 - This memory is used mainly for the parameter working in the storage area.
4. MODEM (IC505)
 - Performs the modulation and the demodulation for FAX communication.
5. Read Section
 - CIS image sensor to read transmitted documents.
6. Motor Driver (IC401)
 - Drives the transmission motor and the reception motor.
7. Thermal Head
 - Contains heat-emitting elements for dot matrix image printing.
8. Analogue Board
 - Composed of ITS circuit and NCU circuit.
9. Sensor Section
 - Composed of a cover open and film end switch, a document set switch, a document top switch, a paper top sensor and a motor position switch.
10. Power Supply Board Switching Section
 - Supplies +6V and +24V to the unit.
11. Flash Memory (IC507) (KX-FP218 Only)
 - This memory is used for voice prompt and TAM.

6.2.1. General Block Diagram

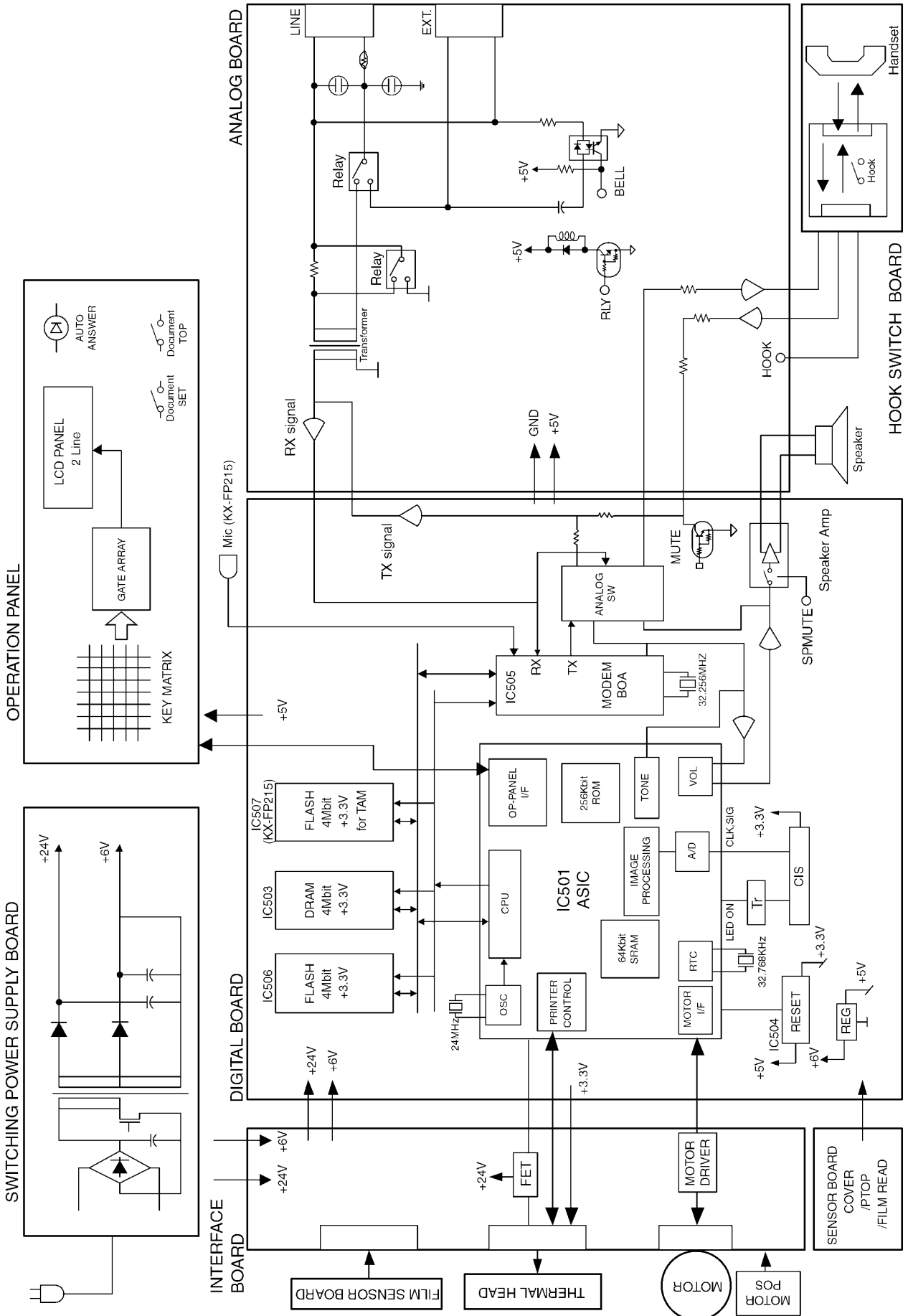

6.3. Control Section

6.3.1. Block Diagram

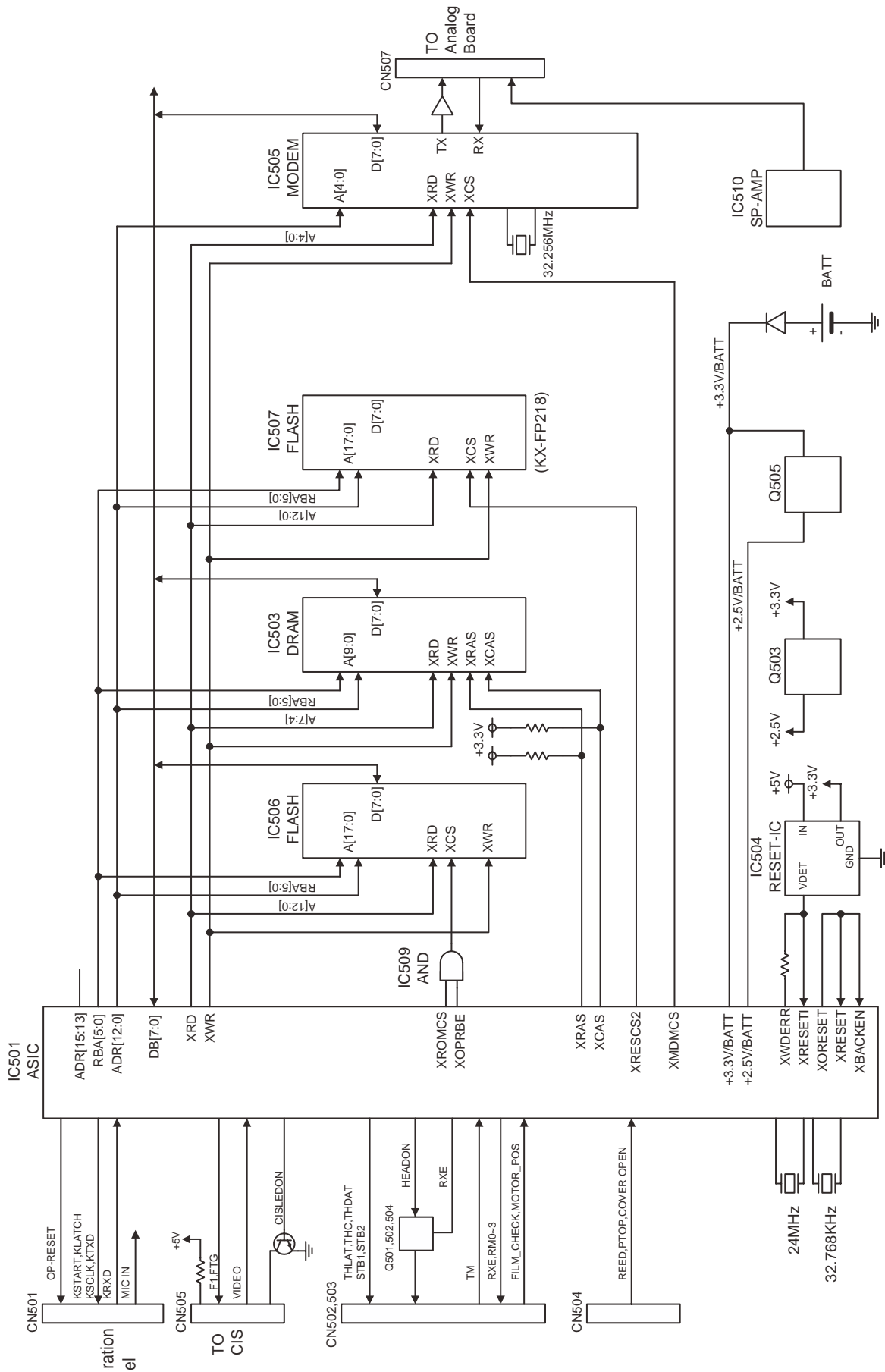

KX-FP207/218FX-S : CONTROL SECTION BLOCK DIAGRAM

6.3.2. Memory Map

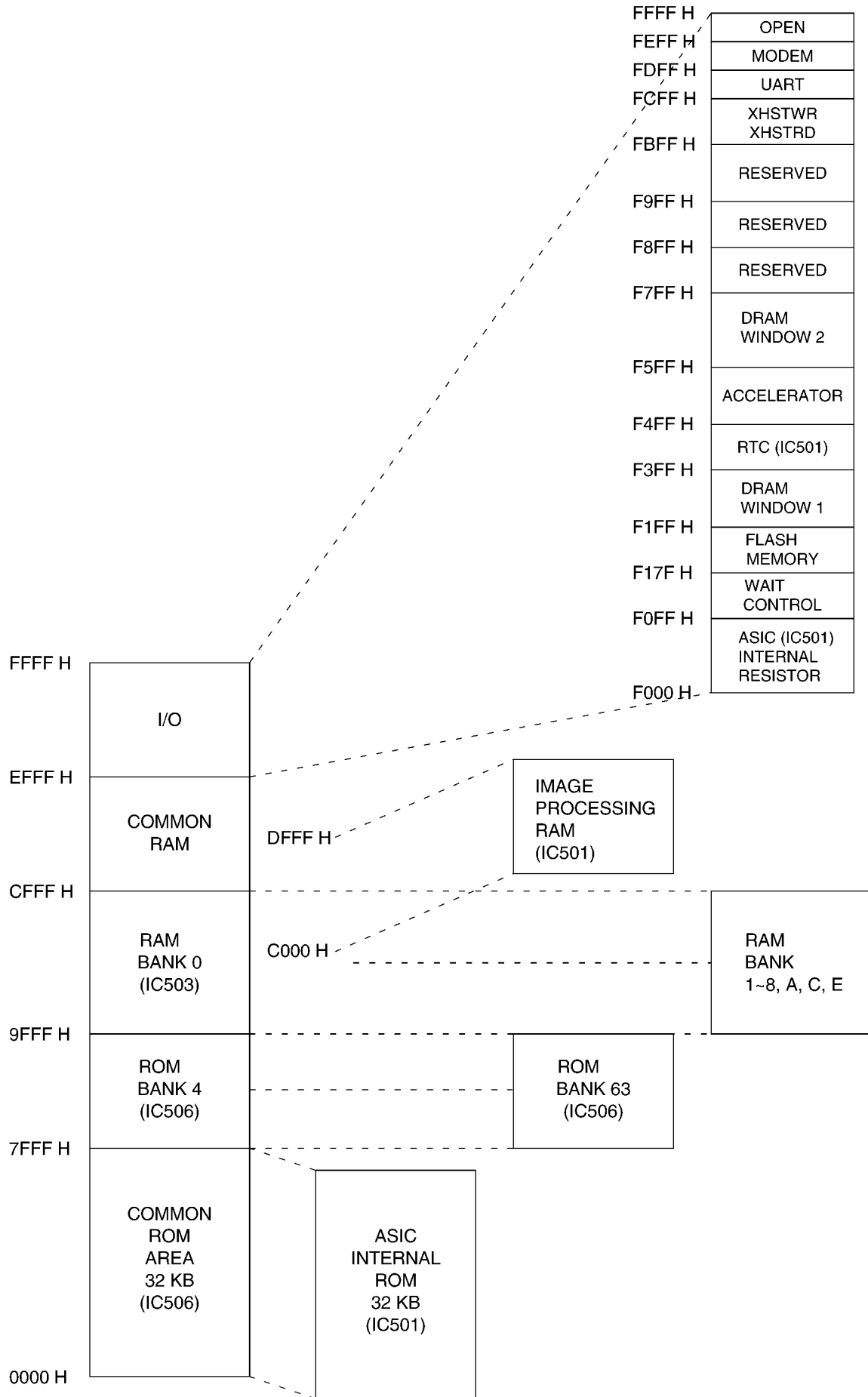

6.3.3. ASIC (IC501)

This custom IC is used for the general FAX operations.

1. CPU:
This model uses a Z80 equivalent to the CPU operating at 12 MHz. Most of the peripheral functions are performed by custom-designed LSIs. Therefore, the CPU only works for processing the results.
2. RTC:
Real Time Clock
3. DECODER:
Decodes the address.
4. ROM/RAM I/F:
Controls the SELECT signal of ROM or RAM and the bank switching.
5. CIS I/F:
Controls the document reading.
6. IMAGE DATA RAM:
This memory is programmed into the ASIC and uses 8 KB for the image processing. (See Fig. A.*)
7. THERMAL HEAD I/F:
Transmits the recorded data to the thermal head.
8. MOTOR I/F:
Controls the transmission motor which feeds the document.
Controls the receiving motor which feeds the recording paper.
9. OPERATION PANEL I/F:
Serial interface with Operation Panel.
10. I/O PORT:
I/O Port Interface.
11. ANALOGUE UNIT:
Electronic volume for the monitor.
Sends beep tones, etc.

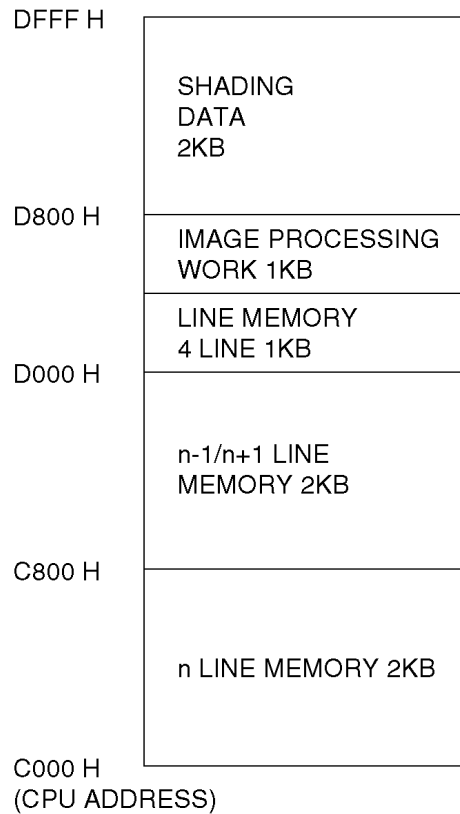

Fig. A

Note:

This memory is incorporated into the ASIC (IC501) and used for the image processing. Fig. A shows the memory map of the Image Data RAM.

Descriptions of Pin Distribution (IC501)

NO.	SIGNAL	I/O	POWER SUPPLIED VOLTAGE	DESCRIPTION
1	VSSA		GND	POWER SOURCE (ANALOG GND)
2	VDDA 3.3		3.3V	POWER SOURCE (ANALOG +3.3V)
3	AIN1	A	3.3V	CIS IMAGE SIGNAL INPUT (SIG)
4	AIN2	A	3.3V	THERMISTOR TEMPERATURE WATCH INPUT
5	AIN3	A	3.3V	LINE VOLTAGE DETECTION SIGNAL INPUT (DCIN)
6	AMON	A	3.3V	ANALOG SIGNAL MONITOR TERMINAL
7	VSS		GND	POWER SOURCE (GND)
8	X32OUT	O	3.3V/BATT	RTC (32.768KHz) CONNECTION
9	X32IN	I	3.3V/BATT	RTC (32.768KHz) CONNECTION
10	VDD (3.3V / B)		-----	POWER SOURCE (+3.3V/LITHIUM BATTERY)
11	XBACEN	I	3.3V/BATT	BACKUP ENABLE
12	XRAMCS	O	3.3V/BATT	NOT USED
13	VDD (3.3V / B)		-----	POWER SOURCE(+3.3V / LITHIUM BATTERY)
14	VDD (2.5V/B)		-----	POWER SOURCE (+2.5V / LITHIUM BATTERY)
15	FTG	O	3.3V	SH SIGNAL OUTPUT FOR CIS (SI)
16	F1	O	3.3V	01 SIGNAL OUTPUT FOR CIS (CLK)
17	F2/OP	O	3.3V	OUTPUT PORT (THON)
18	FR/OP	O	3.3V	OUTPUT PORT (MDMRST)
19	CPC	I	3.3V	INPUT PORT (CPC)
20	RVN	I	3.3V	INPUT PORT (REED)
21	IRDATXD/IOP	O	3.3V	OUTPUT PORT (CISLED)
22	IRDARXD/IOP80	I	3.3V	INPUT PORT (PTOP)
23	TXD/IOP	I	3.3V	INPUT PORT (FILMEND)
24	RXD/IOP	O	3.3V	OUTPUT PORT (HS-ALC)
25	XRTS/IOP	I	3.3V	INPUT PORT (HOOK)
26	XCTS/IOP	O	3.3V	OUTPUT PORT (SPMUTE)
27	VDD (2.5V)		-----	POWER SOURCE (+2.5V)
28	TONE1	A	3.3V	TONE OUTPUT
29	TONE2	A	3.3V	TONE OUTPUT
30	VOLUREF	A	3.3V	ANALOG REF VOLTAGE
31	VOLUOUT	A	3.3V	VOLUME OUTPUT
32	VOLUIN	A	3.3V	VOLUME INPUT
33	XNMI	I	3.3V	HIGH FIXED
34	FMEMDO/IOP	O	3.3V	OUTPUT PORT (CIS ON)
35	VDD (3.3V)		-----	POWER SOURCE (+3.3V)
36	VSS		GND	POWER SOURCE (GND)
37	VSS		GND	POWER SOURCE (GND)
38	VDD (3.3V)		-----	POWER SOURCE (+3.3V)
39	MIDAT/IOP	O	3.3V	PORT (DATA)
40	MICLK/IOP	O	3.3V	PORT (DR)
41	MILAT/IOP	O	3.3V	PORT (CD)
42	20KOSC/IOP	I/O	3.3V	PORT (TONEIEN)
43	XWAIT	I	3.3V	INPUT PORT (MPOS)
44	HSTRD/IOP	O	3.3V	OUTPUT (DCLK)
45	HSTWR/IOP	O	3.3V	OUTPUT PORT (XHSTWR)
46	XOPRBE	O	3.3V	MFCS
47	ADR15	O	3.3V	CPU ADDRESS BUS 15 (NOT USED)
48	ADR14	O	3.3V	CPU ADDRESS BUS 14 (NOT USED)
49	ADR13	O	3.3V	CPU ADDRESS BUS 13 (NOT USED)
50	VDD (2.5V)		-----	POWER SOURCE (+2.5V)
51	XOUT	O	3.3V	SYSTEM CLOCK (24MHz)
52	XIN	I	3.3V	SYSTEM CLOCK (24MHz)
53	VSS		GND	POWER SOURCE (GND)
54	VDD (3.3V)		-----	POWER SOURCE (+3.3V)
55	XTEST	O	3.3V	24MHz CLOCK
56	TEST1	I	3.3V	HIGH FIXED

NO.	SIGNAL	I/O	POWER SUPPLIED VOLTAGE	DESCRIPTION
57	TEST2	I	3.3V	HIGH FIXED
58	TEST3	I	3.3V	HIGH FIXED
59	TEST4	I	3.3V	HIGH FIXED
60	XMDMINT	I	3.3V	MODEM INTERRUPT
61	XMDMCS	O	3.3V	MODEM CHIP SELECT
62	XRAS/IOP	O	3.3V	DRAM (IC503) ROW ADDRESS STROBE
63	XCAS1/IOP	O	3.3V	DRAM (IC503) CULUM ADDRESS STROBE
64	XCAS2/IOP	I	3.3V	INPUT PORT (COVER)
65	XRESCS2	O	3.3V	FLASH CHIP SELECT (XRESCS2)
66	DB3	I/O	3.3V	CPU DATA BUS 3
67	DB2	I/O	3.3V	CPU DATA BUS 2
68	DB4	I/O	3.3V	CPU DATA BUS 4
69	DB1	I/O	3.3V	CPU DATA BUS 1
70	DB5	I/O	3.3V	CPU DATA BUS 5
71	VDD (3.3V)		-----	POWER SOURCE (+3.3V)
72	VSS		GND	POWER SOURCE (GND)
73	VSS		GND	POWER SOURCE (GND)
74	VDD (3.3V)		-----	POWER SOURCE (+3.3V)
75	DB0	I/O	3.3V	CPU DATA BUS 0
76	DB6	I/O	3.3V	CPU DATA BUS 6
77	DB7	I/O	3.3V	CPU DATA BUS 7
78	XROMCS	O	3.3V	ROM (IC502) CHIP SELECT
79	RD	O	3.3V	CPU RD
80	WR	O	3.3V	CPU WR
81	ADR0	O	3.3V	CPU ADDRESS BUS 0
82	ADR1	O	3.3V	CPU ADDRESS BUS 1
83	ADR2	O	3.3V	CPU ADDRESS BUS 2
84	ADR3	O	3.3V	CPU ADDRESS BUS 3
85	ADR4	O	3.3V	CPU ADDRESS BUS 4
86	ADR5	O	3.3V	CPU ADDRESS BUS 5
87	VSS		GND	POWER SOURCE (GND)
88	VDD (2.5V)		-----	POWER SOURCE (+2.5V)
89	ADR6	O	3.3V	CPU ADDRESS BUS 6
90	ADR7	O	3.3V	CPU ADDRESS BUS 7
91	ADR8	O	3.3V	CPU ADDRESS BUS 8
92	ADR9	O	3.3V	CPU ADDRESS 9
93	ADR10	O	3.3V	CPU ADDRESS 10
94	ADR11	O	3.3V	CPU ADDRESS 11
95	ADR12	O	3.3V	CPU ADDRESS 12
96	RBA0	O	3.3V	ROM/RAM BANK ADDRESS 0
97	RBA1	O	3.3V	ROM/RAM BANK ADDRESS 1
98	RBA2	O	3.3V	ROM/RAM BANK ADDRESS 2
99	RBA3	O	3.3V	ROM/RAM BANK ADDRESS 3
100	RBA4	O	3.3V	ROM/RAM BANK ADDRESS 4
101	RBA5	O	3.3V	ROM/RAM BANK ADDRESS 5
102	RBA6/IOP96	O	3.3V	A19
103	STB1	O	3.3V	STROBE SIGNAL OUTPUT TO THERMAL HEAD
104	STB2	O	3.3V	STROBE SIGNAL OUTPUT TO THERMAL HEAD
105	STB3	O	3.3V	STROBE SIGNAL OUTPUT TO THERMAL HEAD
106	XRESET	I	3.3V	RESET INPUT
107	VDD (3.3V)		-----	POWER SOURCE (+3.3V)
108	VSS		GND	POWER SOURCE (GND)
109	VSS		GND	POWER SOURCE (GND)
110	VDD (3.3V)		-----	POWER SOURCE (+3.3V)
111	XORESET	O	3.3V	NOT USED
112	VDD(5V)		-----	POWER SOURCE (+5V)
113	VSS		GND	POWER SOURCE (GND)

NO.	SIGNAL	I/O	POWER SUPPLIED VOLTAGE	DESCRIPTION
114	XRESETI	I	3.3V	RESET INPUT
115	WDERR	O	3.3V	WATCHED ERROR OUTPUT SIGNAL
116	THDAT	O	3.3V	RECORDED IMAGE OUTPUT (XTHDAT)
117	THCLK	O	3.3V	CLOCK OUTPUT FOR DATA TRANSFER (XTHCLK)
118	THLAT	O	3.3V	PULSE OUTPUT FOR DATA LATCH (XTHLAT)
119	STBNP	I	3.3V	INPUT PORT (TEST)
120	RM0/IOP	O	3.3V	OUTPUT PORT (OPRESET)
121	RM1/IOP	I/O	3.3V	(TEL RXEN)
122	RM2/IOP	I/O	3.3V	(HS RXEN)
123	RM3/IOP	I/O	3.3V	MDMTXEN
124	RXE/IOP	I	3.3V	INPUT PORT (BELL)
125	TMO	O	3.3V	MOTOR A PHASE
126	VDD (2.5V)		----	POWER SOURCE (+2.5V)
127	VSS		GND	POWER SOURCE (GND)
128	TM1/IOP	O	3.3V	MOTOR B PHASE
129	TM2/IOP	O	3.3V	MOTOR /A PHASE
130	TM3/IOP	O	3.3V	MOTOR /B PHASE
131	TXE/IOP	O	3.3V	MOTOR ENABLE SIGNAL
132	KSTART	O	3.3V	OPERATION PANEL CONTROL
133	KLATCH	O	3.3V	OPERATION PANEL CONTROL
134	KSCLK	O	3.3V	OPERATION PANEL CONTROL
135	KTXD	O	3.3V	OPERATION PANEL CONTROL
136	KRXD	I	3.3V	OPERATION PANEL CONTROL
137	FMEMCLK/IOP	O	3.3V	OUTPUT PORT (BREAK)
138	FMEMDI/IOP	O	3.3V	OUTPUT PORT (DR)
139	ADSEL1	O	3.3V	CHANNEL SELECT SIGNAL FOR AIN2
140	VDDA (2.5V)		2.5V	POWER SOURCE (ANALOG +2.5V)
141	VREFB	A	3.3V	A/D CONVERTER'S ZERO STANDARD VOLTAGE OUTPUT
142	VCL	A	3.3V	ANALOG PART STANDARD VOLTAGE SIGNAL
143	VREFT	A	3.3V	A/D CONVERTER'S FULL SCALE VOLTAGE OUTPUT
144	VSSA		GND	POWER SOURCE (ANALOG GND)

6.3.4. Flash Memory (IC506)

This 512KB ROM (FLASH MEMORY) carries a common area of 32KB and bank areas which each have 8KB (BK4~BK63). The addresses from 0000H to 7FFFH are for the common area and from 8000H to 9FFFH are for the bank areas.

6.3.5. Dynamic RAM (IC503)

The DRAM serves as CPU and receives memory.

The address is F200H~F3FFH (DRAM access window 1) and F600H~F7FFH (DRAM access window 2).

6.3.6. Reset Circuit (Watch dog timer)

The output signal (reset) from pin 4 of the voltage detect IC (IC504) is input to the ASIC (IC501) 114 pin.

Circuit Diagram

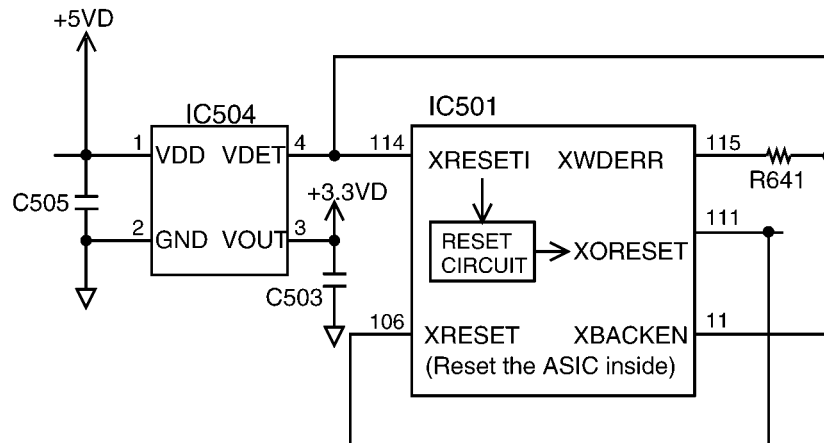

1. During a momentary power interruption, a positive reset pulse of 50~70 msec is generated and the system is reset completely.

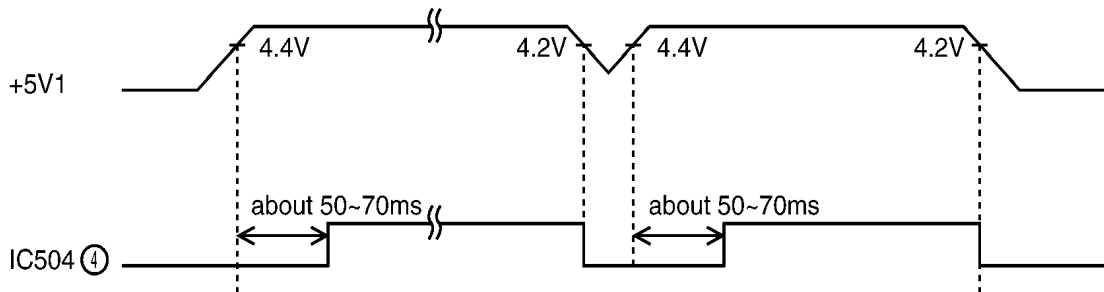

2. The watch dog timer, built-in the ASIC (IC501), is initialized by the CPU about every 1.5 ms. When a watch dog error occurs, pin 115 of the ASIC (IC501) becomes low level. The terminal of the 'WDERR' signal is connected to the reset line, so the 'WDERR' signal works as the reset signal.

6.3.7. RTC Backup Circuit

1. Function

This unit has a lithium battery (BAT501) which works for Real Time Clock IC (RTC: inside IC501). The RTC continues to work, backed up by a lithium battery even when the power switch is OFF. The user parameters for autodial numbers, the system setup data and others are in the FLASH MEMORY (IC506).

2. RTC Inside (IC501) Backup Circuit Operation

When the power switch is turned ON, power is supplied through Q505 to the RTC (inside IC501). At this time, the voltage at pin 14 of the IC501 is +2.5V. When the power switch is turned OFF, the BAT501 supplies power to RTC through D501 and Q505. The voltage at pin 14 of IC501 is about +2.2V. When the power switch is OFF and the voltage of +3.3V decreases, pin 14 of RTC (IC501) becomes roughly the same voltage as the battery voltage. RTC goes into the backup mode, in which the power consumption is lower.

Circuit Diagram

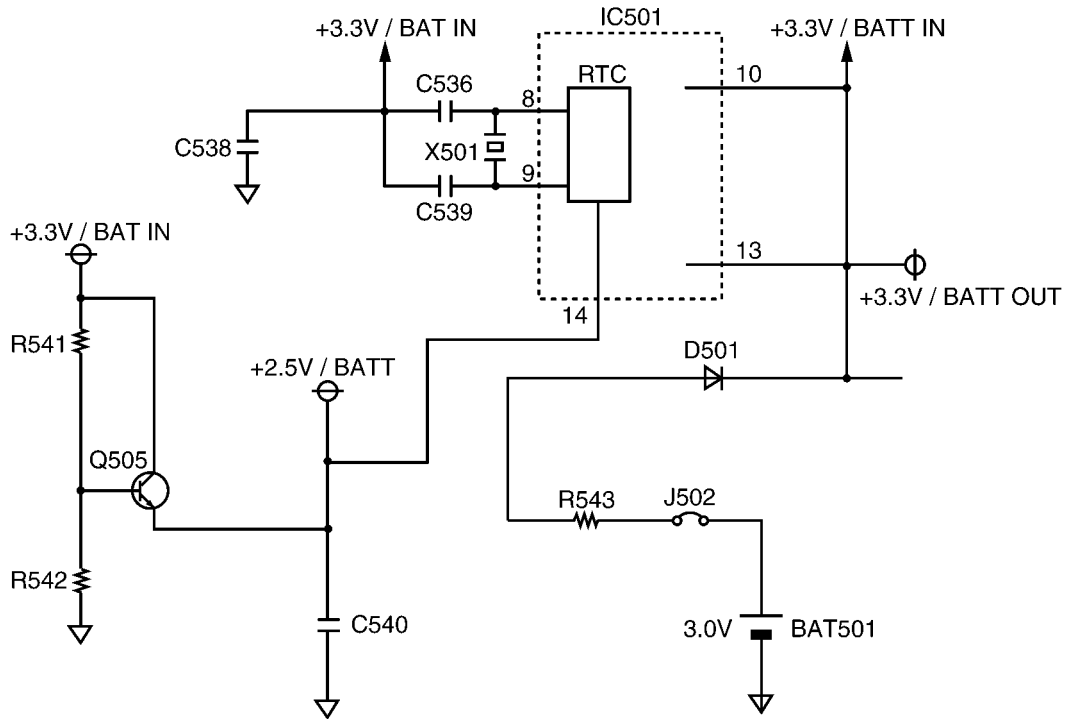

6.3.8. Supervision Circuit for the Terminal Head Temperature

1. Function

The thermistor changes the resistor according to the temperature and uses the thermistor's characteristics. The output of pin 139 of IC501 becomes a low level. Then when it becomes a high level, it triggers point A. In point C, according to the voltage output time, the thermal head's temperature is detected.

After the thermal head temperature is converted to voltage in B, it is then changed to digital data in the A/D converter inside IC501. The CPU decides the strobe width of the thermal head according to this value. Therefore, this circuit can keep the thermal head at an even temperature in order to stabilize the printing density and prevent the head from being overheated.

Circuit Diagram

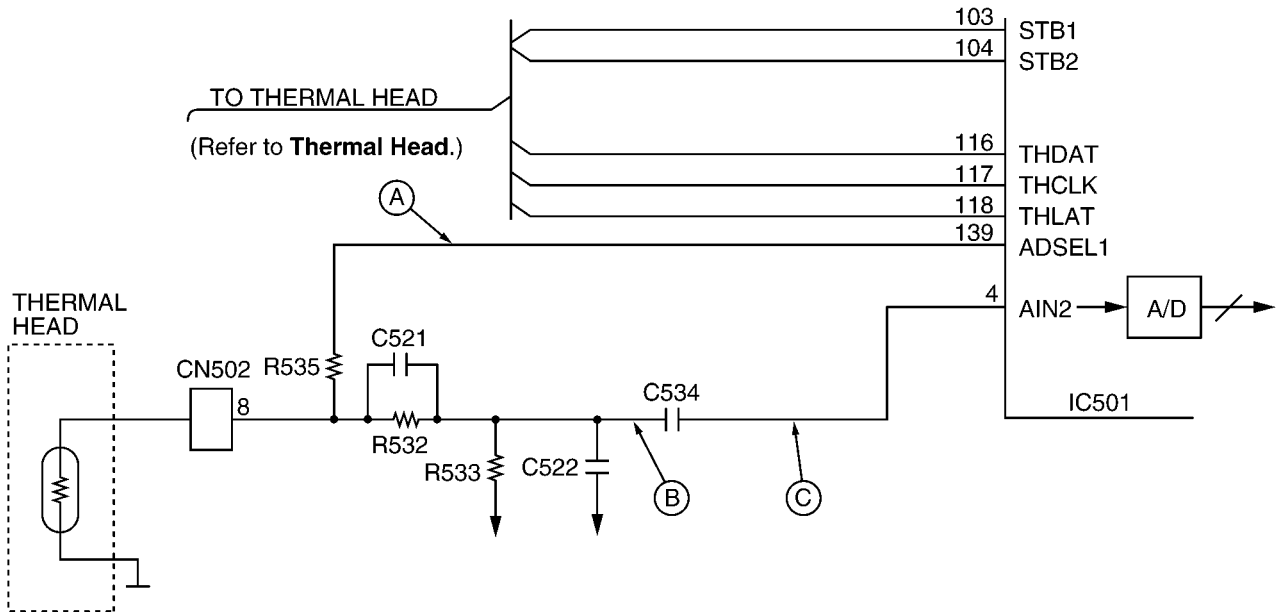

Timing Chart

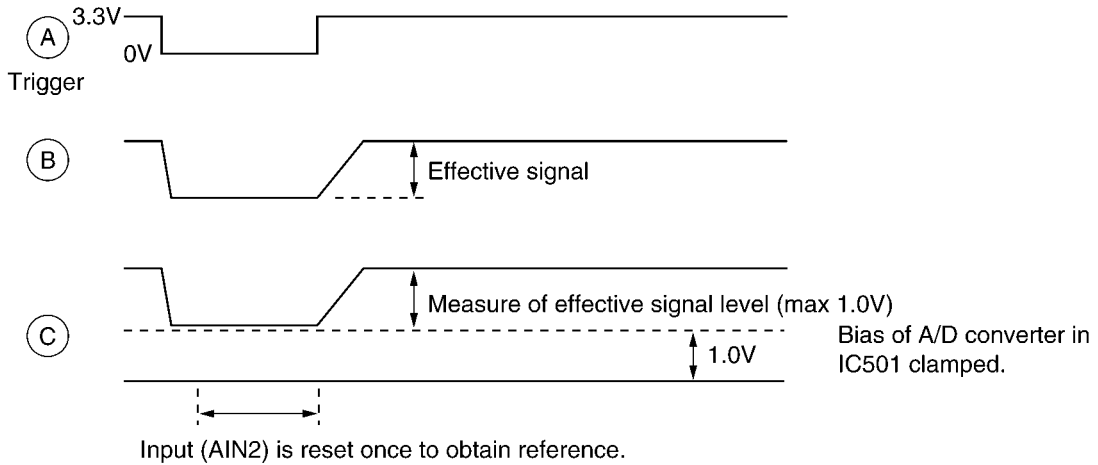

REFERENCE:
Thermal Head (P.24)

6.4. Facsimile Section

6.4.1. Image Data Flow During Facsimile Operation

Copy (Fine, Super-Fine, Half Tone)

1. Line information is read by CIS (to be used as the reference white level) via route1, and is input to IC501. Refer to **Block Diagram** (P.23)
2. In IC501, the data is adjusted to a suitable level for A/D conversion in the Analogue Signal Processing Section, and via route2 it is input to A/D conversion (8 bit). After finishing A/D conversion, the data is input to the Image Processing Section via route3. Then via route4 and route5, it is stored in RAM as shading data.
3. The draft's information that is read by CIS is input to IC501 via route1. After it is adjusted to a suitable level for A/D conversion via route2, the draft's information is converted to A/D (8 bit), and it is input to the Image Processing Section. The other side, the shading data which flows from RAM via route6 and route7, is input to the Image Processing Section. After finishing the draft's information image processing, white is regarded as "0" and black is regarded as "1". Then via routes4 and 5, they are stored in RAM.
4. The white/black data stored as above via routes6 and8 is input to the P/S converter. The white/black data converted to serial data in the P/S converter is input to the Thermal Head via route9 and is printed out on recording paper.

Note:

- Standard: Reads 3.85 times/mm
- Fine: Reads 7.7 times/mm
- Super-Fine: Reads 15.4 times/mm

Transmission

1. Same processing as **Copy** items 1 - 3.
2. The data stored in the RAM of IC501 is output from IC501 via routes6 and 10, and is stored in the system bus. Via route11, it is stored in the communication buffer inside DRAM (IC503).
3. While retrieving data stored in the communication buffer synchronous with the modem, the CPU (inside IC501) inputs the data to the modem along route12, where it is converted to serial analogue data and forwarded over the telephone lines via the NCU Section.

Reception

1. The serial analogue image data is received over the telephone lines and input to the modem via the NCU section, where it is demodulated to parallel digital data. Then the CPU (IC501) stores the data in the communication buffer DRAM (IC503) along route12.
2. The data stored in DRAM (IC503) is decoded by the CPU (IC501) via route12, and is stored in DRAM (IC503) via routes13 and 5.
3. Same processing as **Copy** item 4.

6.4.2. Block Diagram

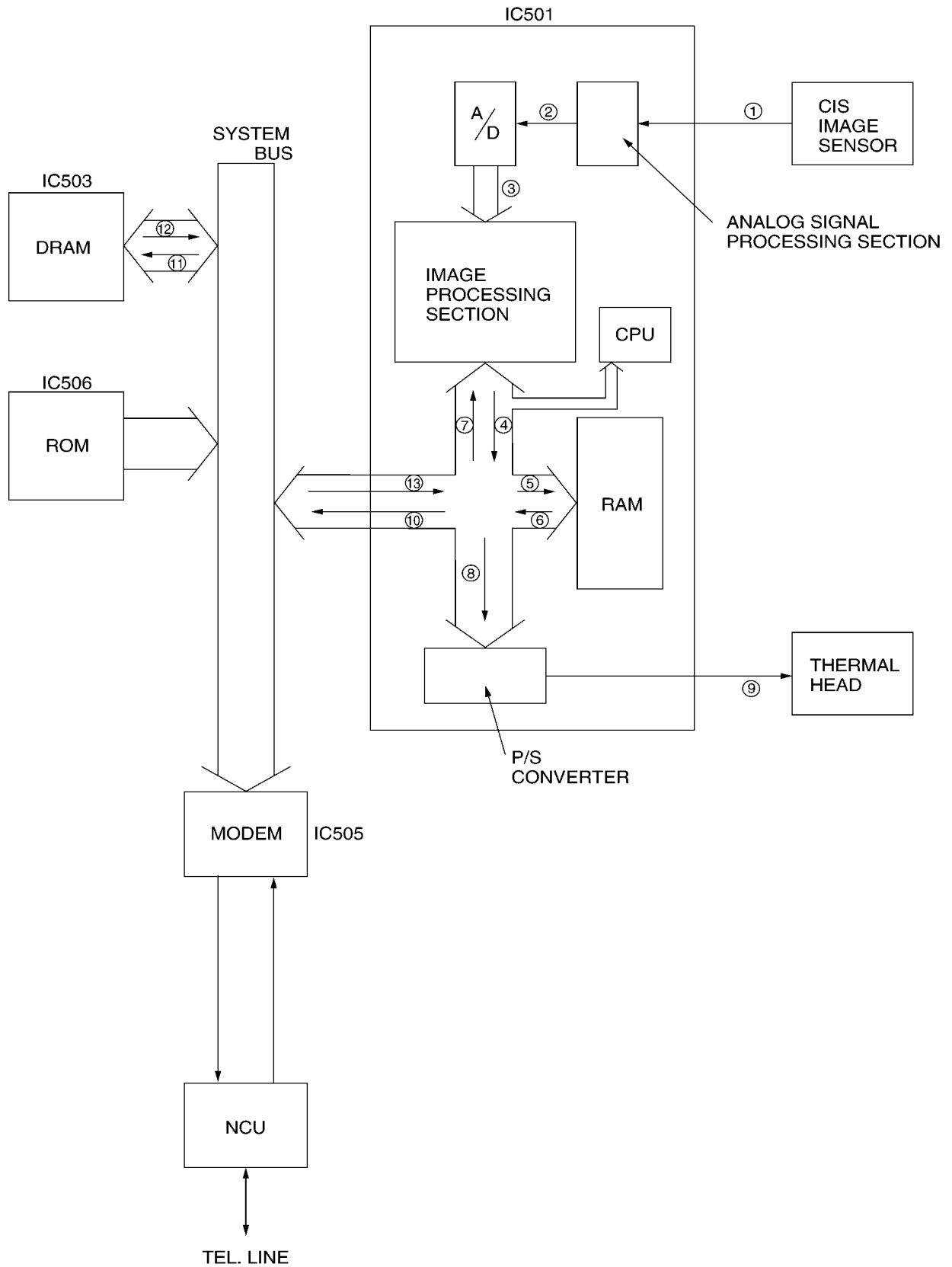

6.4.3. Thermal Head

1. Function

This unit utilizes the state of the art thermal printer technology.

The ink film is chemically processed. The ink film is comprised of two parts: an ink layer and a base film. When the thermal-head contacts this ink film, it emits heat momentarily, and the ink layer is melted and transferred to the paper. If this continues, letters and/or diagrams appear, and the original document is reproduced.

Composition of the receive record section (Thermal recording format)

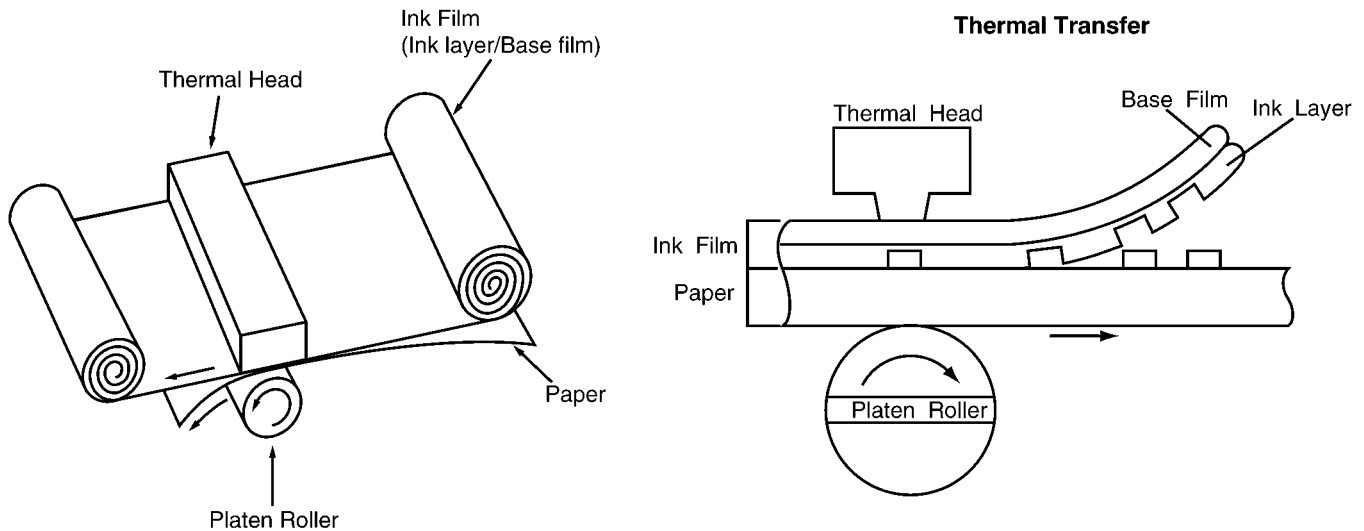

2. Circuit Operation

Refer to the block diagram and the timing chart on the following page.

There are 9 driver ICs aligned horizontally on the thermal head and each one of these ICs can drive 192 heat emitting registers. This means that one line is at a density of $192 \times 9 = 1728$ dots = (8 dots/mm).

White/Black (white=0, black=1) data in one line increments is synchronized at IC501 pin 117 (THCLK), and sent from IC501 pin 116 (THDAT) to the shift register of the ICs. The shift registers of the 9 ICs are connected in series, and upon the shift of dot increment 1728, all the shift registers become filled with data, and a latch pulse is emitted to each IC from IC501 pin 118 (THLAT). With this latch pulse, all the contents of the shift registers are latched to the latch registers. Thereafter, through the addition of strobos from the IC501 pins (103, 104) only black dot locations (=1) among latched data activates the driver, and the current passes to heat the emitting body causing heat emission.

Here, the two line strobos, STB1 and STB2, impress at intervals of 9.216 msec, as required for one-line printout.

The sequence is shown on the next page. [Moreover, for the strobe width, the thermistor value inside the thermal head is detected according to IC501 pin 4. Depending on that value, the strobe width is recorded in ROM (IC506).

Accordingly, the strobe width is determined.

When the thermal head is not used, the IC501 (17, THON) becomes low, Q502 turns OFF, Q401 turns OFF, and the +24 V power supply for the thermal head driver is not impressed to protect the IC.

Circuit Diagram

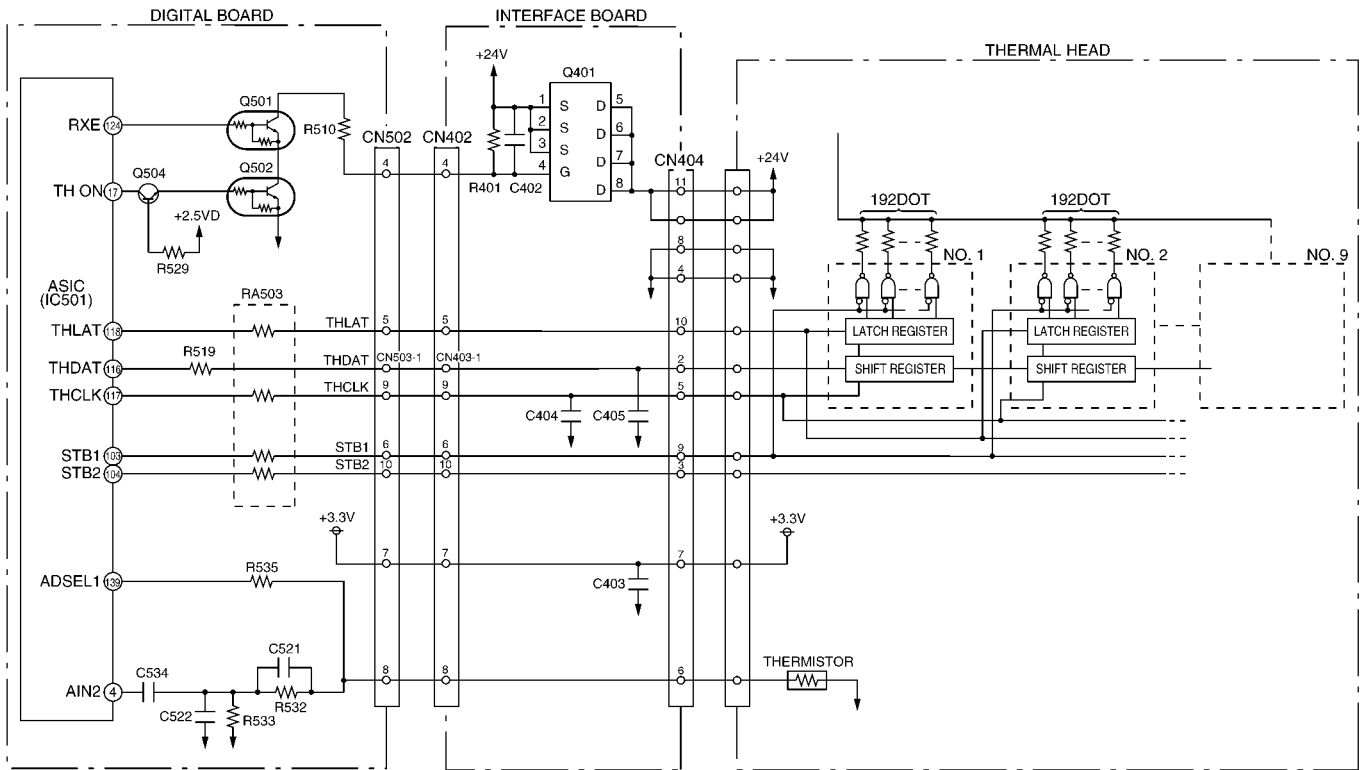

Timing Chart

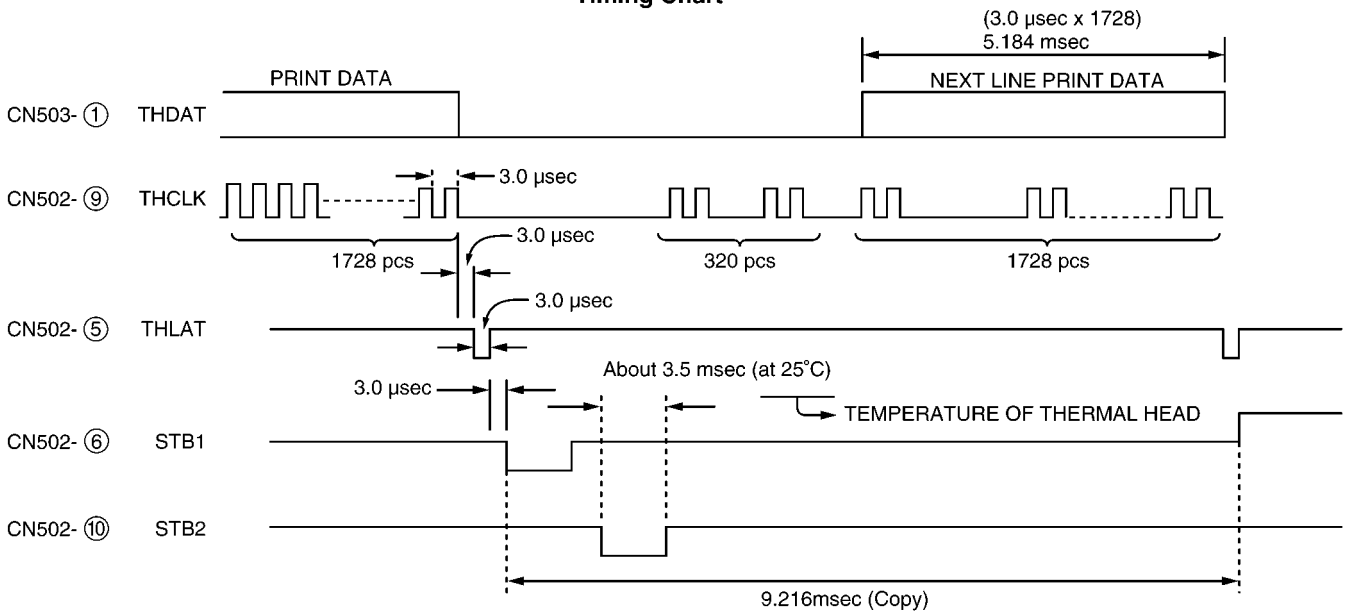

6.4.4. Scanning Block

The scanning block of this device consists of a control circuit and a contact image sensor made up of a celfoc lens array, an LED array, and photoelectric conversion elements.

Circuit Diagram

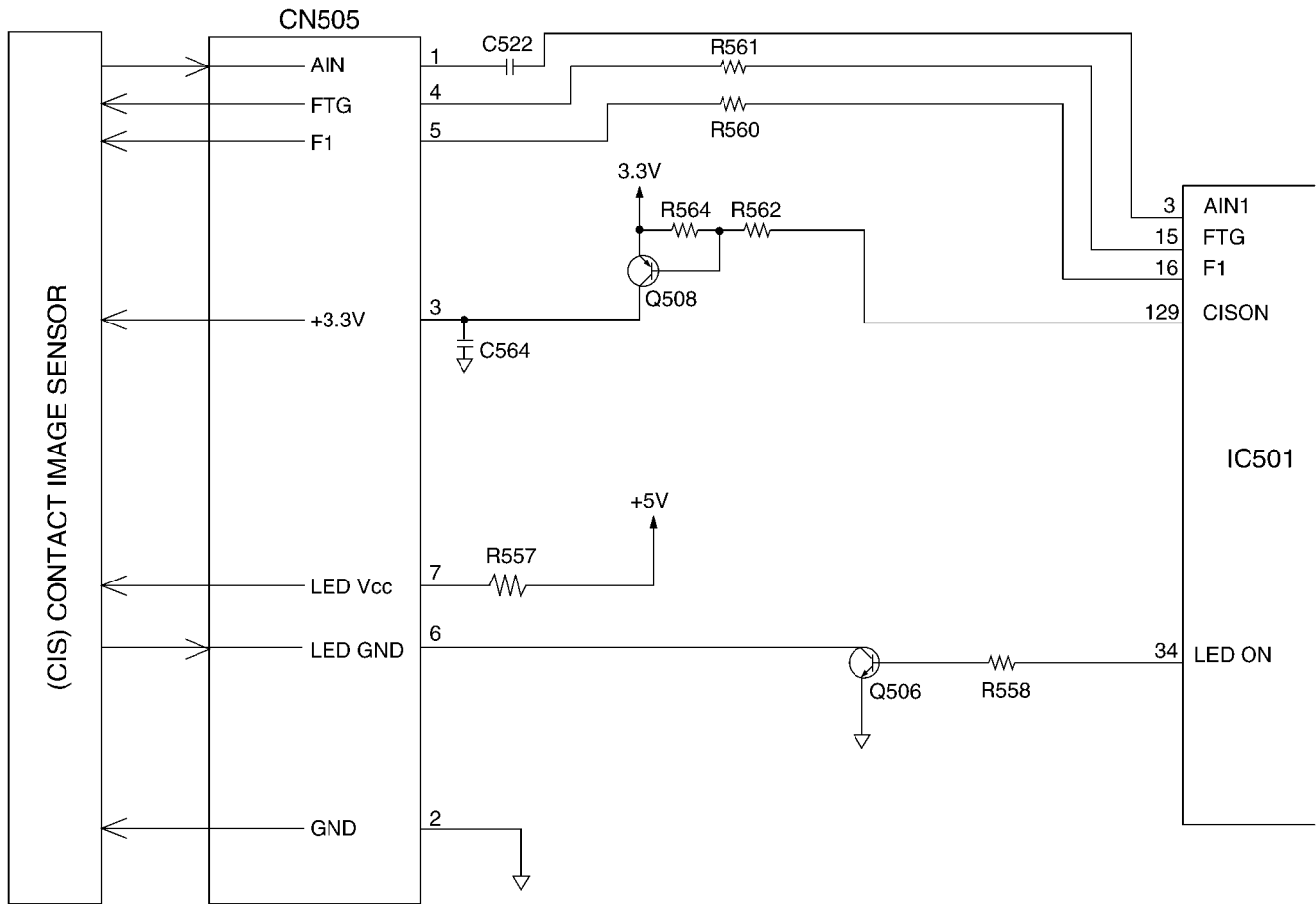

When an original document is inserted and the start button pressed, pin 34 of IC501 goes to a high level and the transistor Q506 turns on. This applies voltage to the LED array to light it. The contact image sensor is driven by each of the FTG-F1 signals output from IC501, and the original image illuminated by the LED array undergoes photoelectric conversion to output an analogue image signal (AIN). The analogue image signal is input to the system ASIC on AIN1 (pin 3 of IC501) and converted into 8-bit data by the A/D converter inside IC501. Then this signal undergoes digital processing in order to obtain a high-quality image.

6.4.5. Stepping Motor Drive Circuit

1. **Function**

The stepping motor works for both transmission and reception.

2. **Motor**

During motor driving, pin 124 of ASIC IC501 becomes a high level, and Q403, Q402 turns ON. As a result, +24V is supplied to the motor coil.

Stepping pulses are output from ASIC IC501 pins, 124, 120~123, causing driver IC401 pins, 14~11 to drive the Motor Coil. The motor coil is energized sequentially in 2 phase increments, which causes a 1-step rotation. A 1-step rotation feeds 0.13 mm of recording paper or document paper.

The timing chart is below.

Stepping Monitor Timing Chart

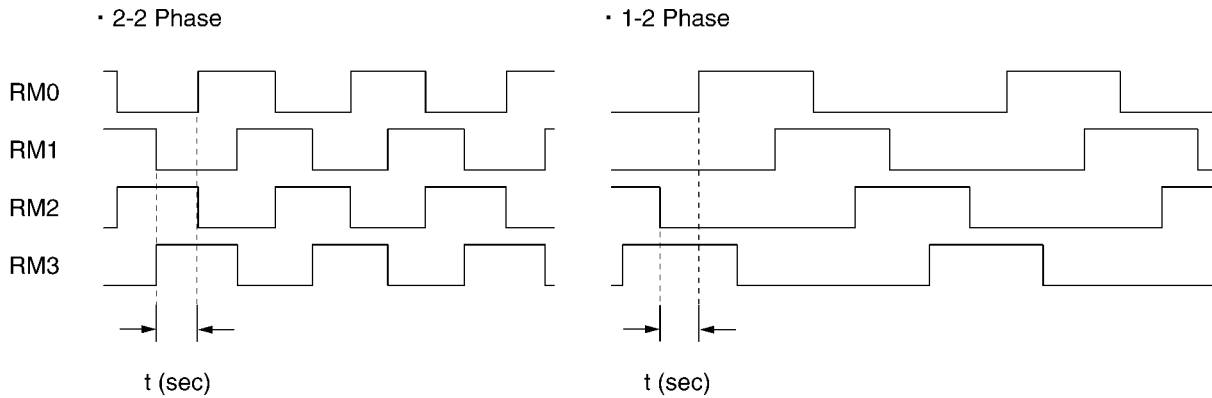

Stepping Motor Drive Mode

Function	Mode	Phase Pattern	Speed
Copy	Fine, Photo	1-2	432 pps (t=1/432)
	Super Fine	1-2	216 pps (t=1/216)
FAX Sending	Standard	2-2	432 pps (t=1/432)
	Fine, Photo	1-2	432 pps (t=1/432)
	Super Fine	1-2	216 pps (t=1/216)
FAX Receiving	Standard, Fine, Photo	1-2	432 pps (t=1/432)
	Super Fine	1-2	216 pps (t=1/216)
Paper Feed	——	1-2	432 pps (t=1/432)
Document Feed	——	1-2	432 pps (t=1/432)
Stand-by	——	All phases are currently off.	None

Circuit Diagram

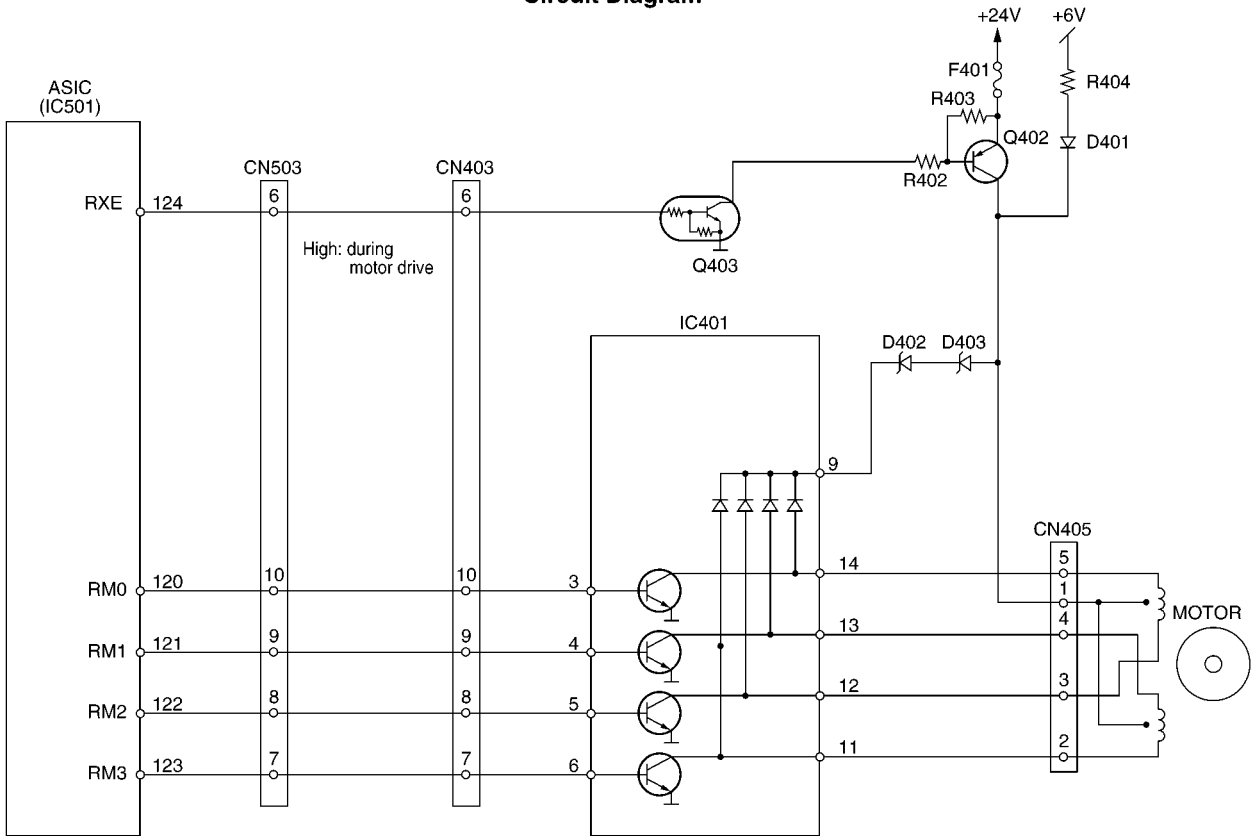

When the motor suspends while it is in the receive mode (about 70~80 msec), pin 124 of ASIC IC501 becomes a low level and Q403 turns OFF. Then Q402 also turns OFF, and instead of +24 V, +6 V is supplied through D401 so that the motor is held in place. When the system is in the stand-by mode, all of the motor drive transistors turn OFF. Consequently, the motor current stops.

6.5. Sensors and Switches

All of the sensor and switches are shown below.

Sensor Circuit Location	Sensor	Sensor or Switch Name	Error Message
Operation Panel	SW351	Document top sensor	[REMOVE DOCUMENT]
	SW352	Document set sensor	[CHECK DOCUMENT]
Sensor P.C.Board	SW1001	Cover Open sensor Paper Top sensor	[CHECK COVER] [PAPER JAMMED]
	SW1002	Film Detection sensor	[FILM EMPTY]
Film End Sensor P.C.Board	SW1003	Film End sensor	[CHECK FILM]
Gear Block	SW1004	Motor Position sensor	[CALL SERVICE2]
HOOK SW P.C.Board	SW1501	Hook switch	_____

Note:

See **Test Mode** (P.58). (#815: Sensor Check)

Sensor Locations

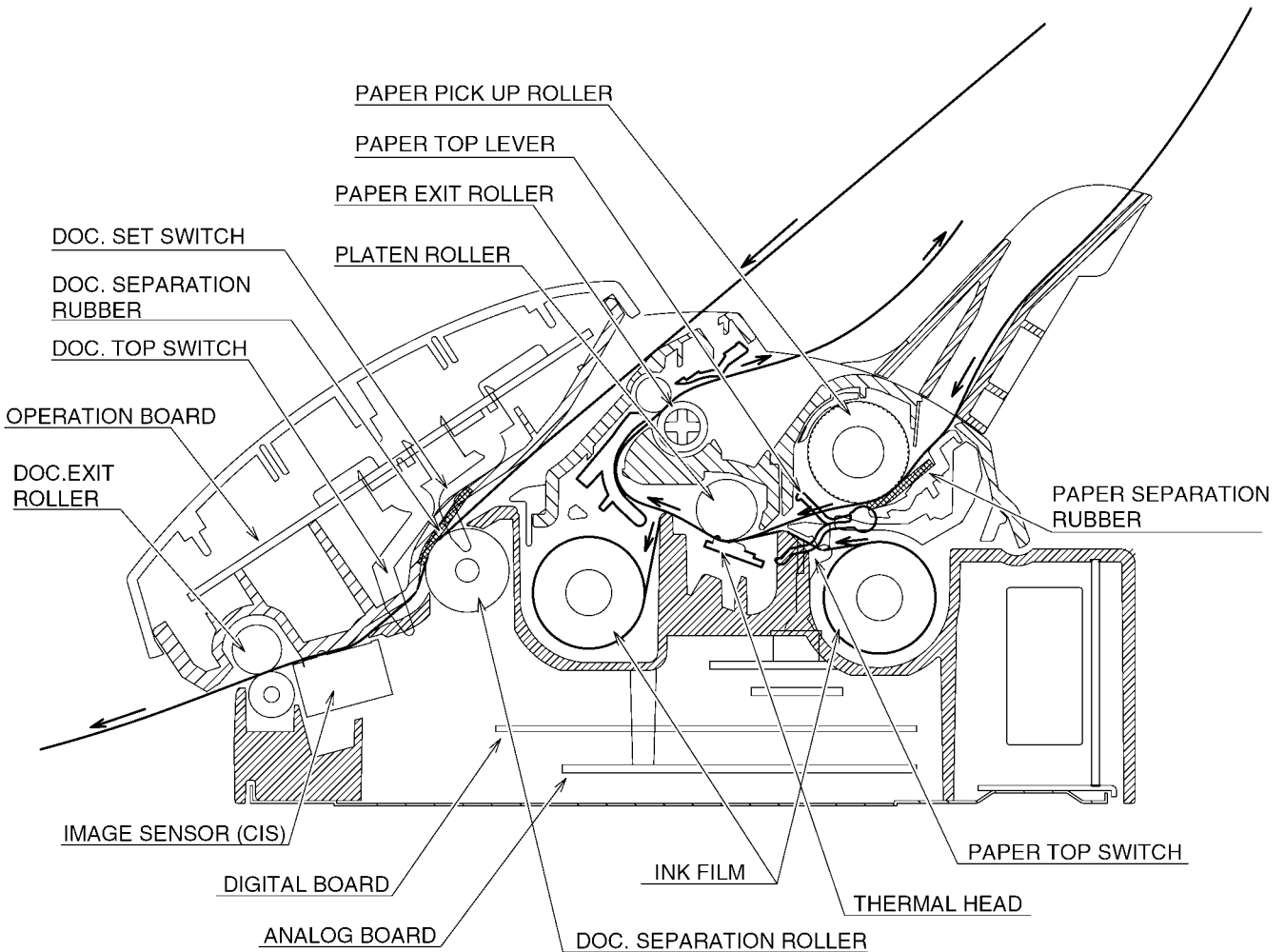

6.5.1. Document Top Sensor (SW351)

When a document is brought to the read position, the SW turns ON, and the input signal of IC301-6 pin (Operation Board) becomes a low level. When there is no document at the read position, the SW turns OFF, and the input signal of IC301-6 pin (Operation Board) becomes a high level.

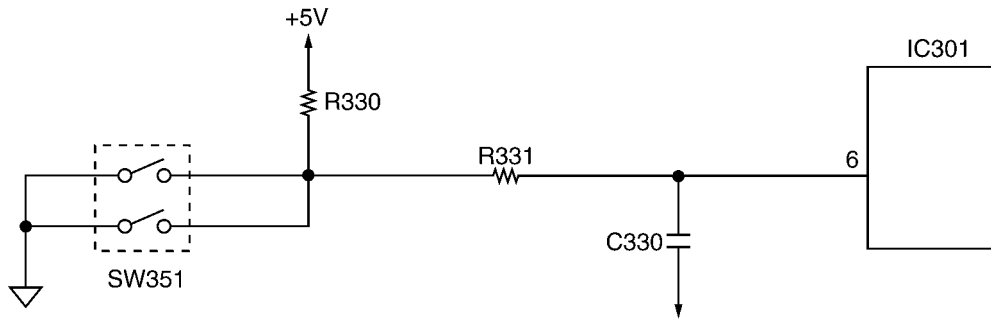

	SW	Signal (IC301-6 pin)
Out of the Read Position	OFF	High level
At the Read Position	ON	Low level

6.5.2. Document Set Sensor (SW352)

When a document is set, the SW turns ON, and the input signal of IC301-9 pin (Operation Board) becomes a low level. When there is no document, the SW turns ON, and the input signal of IC301-9 pin (Operation Board) becomes a high level.

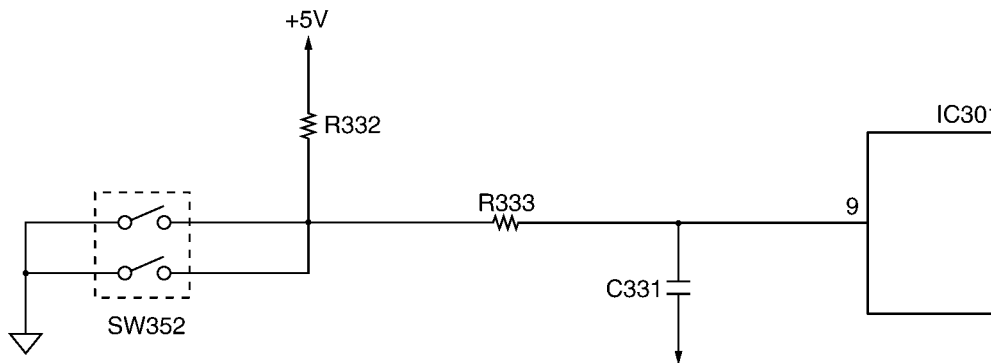

	SW	Signal (IC301-9 pin)
No document	OFF	High level
Set document	ON	Low level

6.5.3. Paper Top Sensor (SW1001)

When the recording paper is loaded on the print head or the recording paper cover is opened, the paper top sensor SW turns ON, and the input signal of IC501-21 pin (Digital Board) becomes a low level. Usually, the SW turns OFF, and the input signal of IC501-21 pin (Digital Board) becomes a high level.

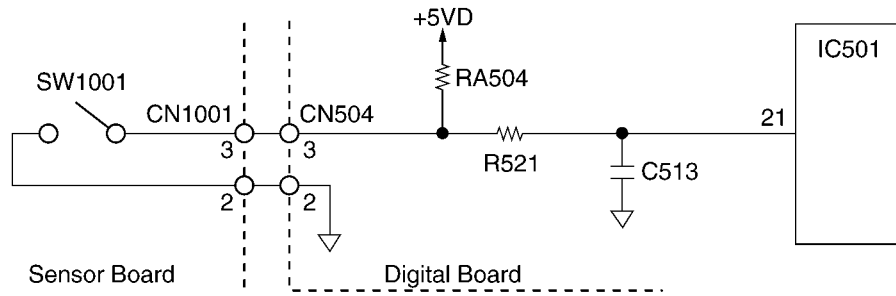

	SW	Signal (IC501-21 pin)
Set recording paper or paper cover is opened	ON	Low level
No recording paper or paper cover is closed	OFF	High level

6.5.4. Cover Open Sensor (SW1001)

When the u-TURN BLOCK is closed, the SW becomes ON, and the input signal of IC501-131 pin (Digital Board) becomes a low level. When the cover is opened, the SW becomes OFF, and the input signal of IC501-131 (Digital Board) pin becomes a high level.

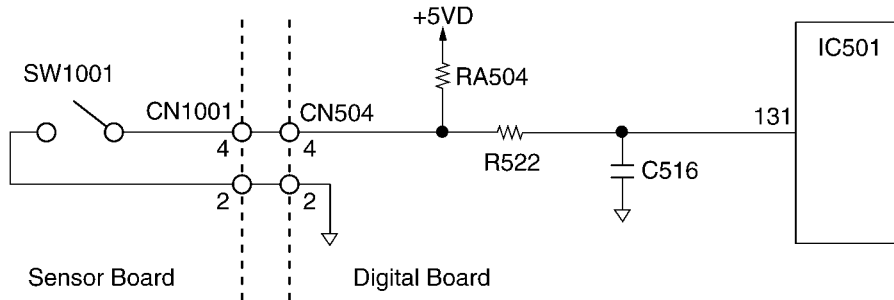

	SW	Signal (IC501-131 pin)
Cover is opened	OFF	High level
Cover is closed	ON	Low level

6.5.5. Film End Sensor (SW1003)

When a film is set, the SW turns ON, and the input signal of IC501-45 pin (Digital Board) becomes a low level. When there is no film, the SW turns OFF, and the input signal of IC501-45 pin (Digital Board) becomes a high level.

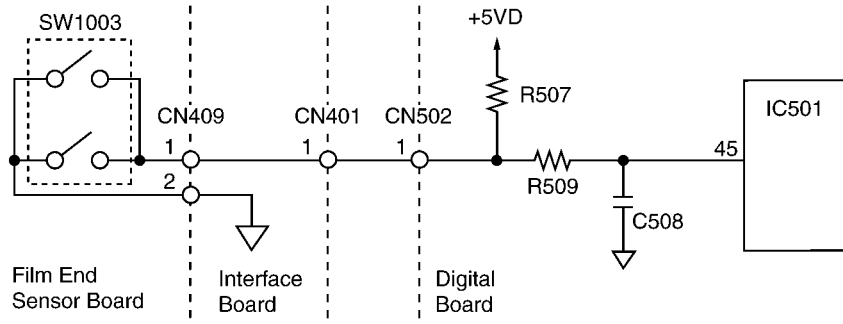

	SW	Signal (IC501-45 pin)
No film	OFF	High level
Set a film	ON	Low level

6.5.6. Motor Position Sensor (SW1004)

This sensor is a detection switch for recording the position of the CAM.

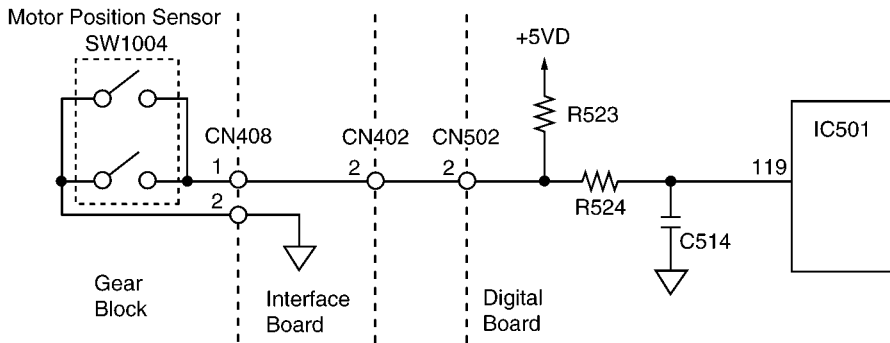

	Signal (IC501-119 pin)
Home position	Low level
Other	High level

6.5.7. Hook Switch (SW1501)

When the handset is lifted, the switch turns ON, and the signal at pin 43 of IC501 becomes low.

When the handset is returned, the switch turns OFF, and the signal at pin 43 of IC501 becomes high.

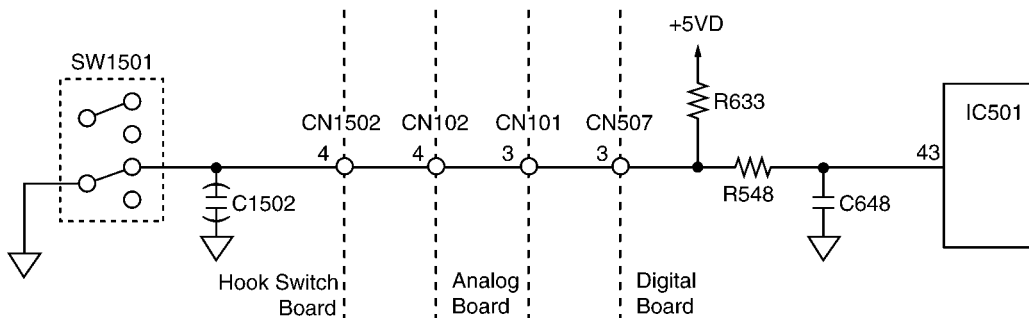

	SW	Signal (IC501-43 pin)
ON-Hook	OFF	High level
OFF-Hook	ON	Low level

6.6. Modem Section

6.6.1. Function

The unit uses a 1 chip modem (IC505) that serves as an interface between the control section for FAX transmission and reception and the telephone line. During a transmitting operation, the digital image signals are modulated and sent to the telephone line.

During a receiving operation, the analogue image signals which are received via the telephone line are demodulated and converted into digital image signals. The communication format and procedures for FAX communication are standardized by ITU-T. This 1 chip modem (IC505) has hardware which sends and detects all of the necessary signals for FAX communication.

It can be controlled by writing commands from the CPU (IC501: inside ASIC) to the register in the modem (IC505).

This modem (IC505) also sends DTMF signals, generates a call tone (from the speaker), and detects a busy tone and dial tones.

Overview of Facsimile Communication Procedures (ITU-T Recommendation):

1. ON CCITT (International Telegraph and Telephone Consultative Committee)

The No. XIV Group of ITU-T, one of the four permanent organizations of the International Telecommunications Union (ITU), investigates and make recommendations on international standards for facsimiles.

2. Definition of Each Group

- Group I (G1)

Official A-4 size documents without using formats which reduce the band width of a signal are sent over telephone lines. Determined in 1968.

Transmission for about 6 minutes at a scanning line density of 3.85 lines/mm.

- Group II (G2)

Using reduction technology in the modulation/demodulation format, an A-4 size document is sent at an official scanning line density of 3.85 lines/mm for about 3 minutes.

Methods to suppress redundancy are not used.

Determined in 1976.

- Group III (G3)

Method of suppressing redundancy in the image signal prior to modulation is used. An A-4 size document is sent within about one minute.

Determined in 1980.

- Group IV (G4)

Transmission is via the data network. A method is provided for suppressing redundancy in signals prior to transmission, and error-free reception of transmission is possible.

The scope of these facsimile applications is not limited simply to transmission of written statements. Through symbiotic linkages with other communication methods, it can be expected to expand to include integrated services.

3. Facsimile Call Time Series

As shown in the following diagram, the facsimile call time series is divided into five phases.

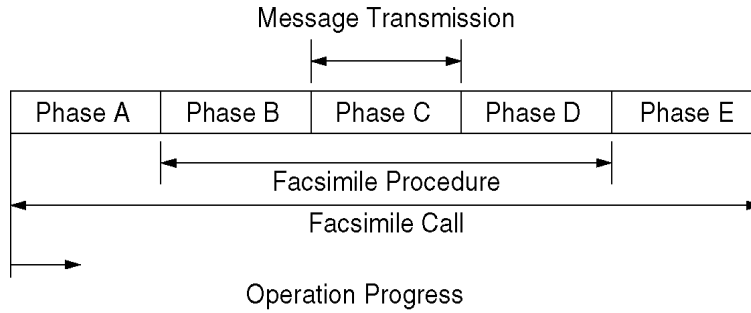

Phase A: Call setting

Call setting can be manual/automatic.

Phase B: Pre-message procedure

Phase B is a pre-processing procedure and sequence for confirming the status of the terminal, transmission route, etc., and for terminal control. It implements terminal preparation status, determines and displays terminal constants, confirms synchronization status, etc. and prepares for transmission of facsimile messages.

Phase C: Message transmission

Phase C is the procedure for the transmitting facsimile messages.

Phase D: Post message procedure

Phase D is the procedure for confirming that the message is completed and received. For continuous transmission, phase B or phase C is repeated for transmission.

Phase E: Call retrieval

Phase E is the procedure for call retrieval, that is for circuit disconnection.

4. Concerning Transmission Time

$$\text{Transmission Time} = \text{Control Time} + \text{Image Transmission Time} + \text{Hold Time}$$

Transmission time consists of the following.

Control time:

This is time at the start of transmission when the functions at the sending and receiving sides are confirmed, the transmission mode is established, and transmission and reception are synchronized.

Image transmission time:

This is the time required for the transmission of document contents (image data). In general, this time is recorded in the catalog, etc.

Hold time:

This is the time required after the document contents have been sent to confirm that the document was actually sent, and to check for telephone reservations and/or the existence of continuous transmission.

5. Facsimile Standards

Item	Telephone Network Facsimile
	G3 Machine
Connection Control Mode	Telephone Network Signal Mode
Terminal Control Mode	T. 30 Binary
Facsimile Signal Format	Digital
Modulation Mode	PSK (V. 27 ter) or QAM (V. 29) [or TCM(V.17) FP218]
Transmission Speed	300 bps (Control Signal) 2400, 4800, 7200, 9600bps FP218 (FAX Signal) 2400, 4800, 7200, 9600, 12000, 14400bps FP218 (FAX Signal)
Redundancy Compression Process (Coding Mode)	1 dimension: MH Mode 2 dimension: MR Mode (K=2.4) , MMR (FP218)
Resolution	Main Scan: 8 pel/mm Sub Scan: 3.85, 7.7l/mm
Line Synchronization Signal	EOL Signal
1 Line Transmission Time [ms/line]	Depends on the degree of data reduction. Minimum Value: 10, 20 Can be recognized in 40ms.

6. Explanation of Communication and Compression Technology

a. G3 Communication Signals (T. 30 Binary Process)

For G3 Facsimile communication, this is the procedure for exchanging control signals between the sending and receiving machines both before and after transmission of image signals.

Control signals at 300 bps FSK are: 1850 Hz...0, 1650Hz...1.

An example of a binary process in G3 communication is shown below.

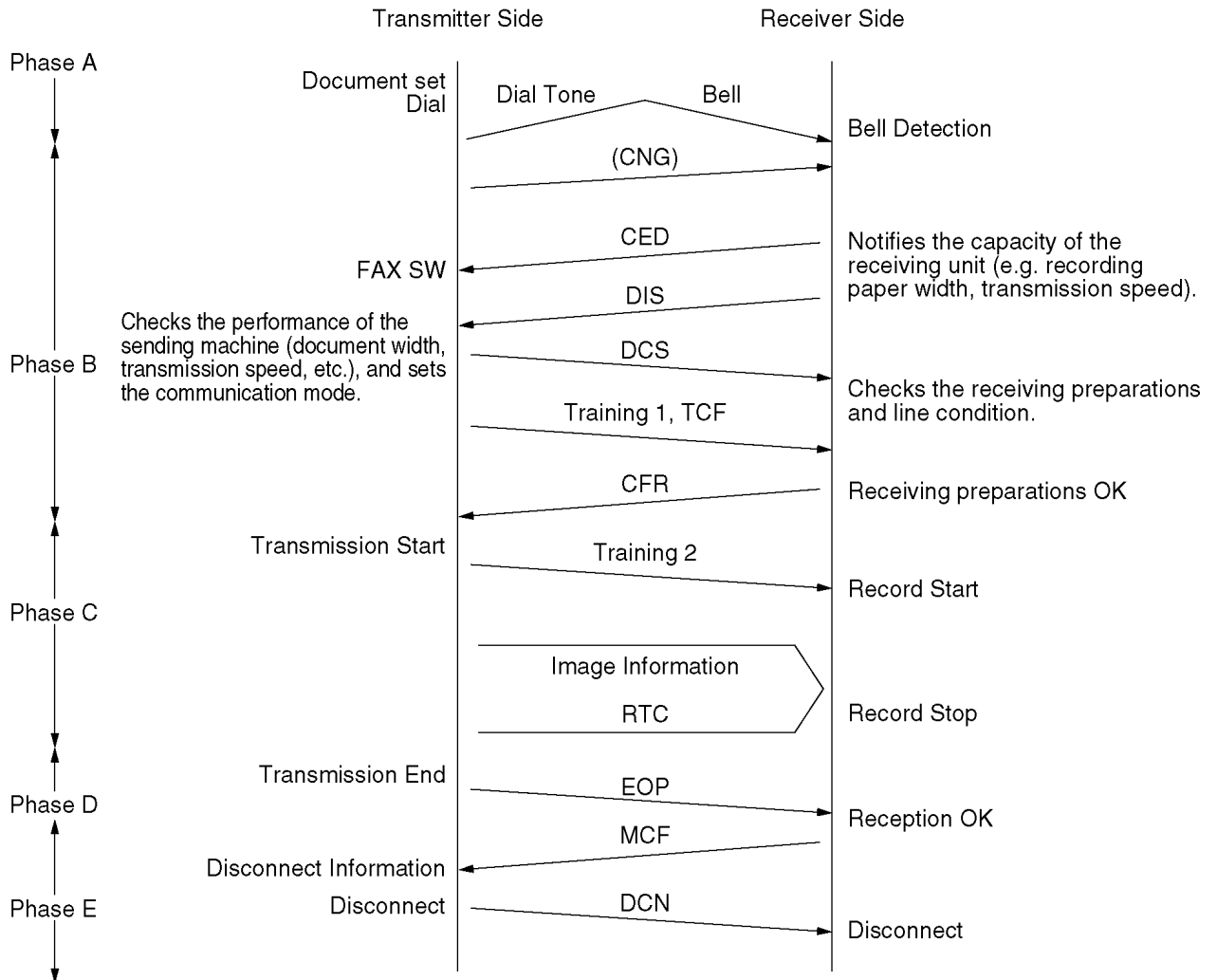

Explanation of Signals

Control signals are comprised mainly of 8-bit identification signals and the data signals added to them. Data signals are added to DIS and DCS signals.

Signal.....DIS (Digital Identification Signal)

Identification Signal Format.....00000001

Function:

Notifies the capacity of the receiving unit. The added data signals are as follows.

Signal.....DCS (Digital Command Signal)

Identification Signal Format.....X1000001

Example (Some models do not support the following items.):

Bit No.	DIS/DTC	DCS
1	Transmitter --- T.2 operation	
2	Receiver --- T.2 operation	Receiver --- T.2 operation
3	T.2 IOC = 176	T.2 IOC = 176
4	Transmitter --- T.3 operation	
5	Receiver --- T.3 operation	Receiver --- T.3 operation
6	Reserved for future T.3 operation features	
7	Reserved for future T.3 operation features.	
8	Reserved for future T.3 operation features.	
9	Transmitter --- T.4 operation	

Bit No.	DIS/DTC	DCS
10	Receiver --- T.4 operation	Receiver --- T.4 operation
11,12,13,14	Data signaling rate	Data signaling rate
0,0,0,0	V.27 ter fall back mode	2400 bit/s, V.27 ter
0,1,0,0	V.27 ter	4800 bit/s, V.27 ter
1,0,0,0	V.29	9600 bit/s, V.29
1,1,0,0	V.27 ter and V.29	7200 bit/s, V.29
0,0,1,0	Not used	14400 bit/s, V.33
0,1,1,0	Reserved	12000 bit/s, V.33
1,0,1,0	Not used	Reserved
1,1,1,0	V.27 ter and V.29 and V.33	Reserved
0,0,0,1	Not used	14400 bit/s, V.17
0,1,0,1	Reserved	12000 bit/s, V.17
1,0,0,1	Not used	9600 bit/s, V.17
1,1,0,1	V.27 ter and V.29 and V.33 and V.17	7200 bit/s, V.17
0,0,1,1	Not used	Reserved
0,1,1,1	Reserved	Reserved
1,0,1,1	Not used	Reserved
1,1,1,1	Reserved	Reserved
15	R8×7.7 lines/mm and/or 200×200 pels/25.4mm	R8×7.7 lines/mm and/or 200×200 pels/25.4mm
16	Two-dimensional coding capability	Two-dimensional coding capability
17, 18	Recording width capabilities	Recording width
(0, 0)	1728 picture elements along scan line length of 215 mm ± 1%	1728 picture elements along scan line length of 215 mm ± 1%
(0, 1)	1728 picture elements along scan line length of 215 mm ± 1%	2432 picture elements along scan line length of 303 mm ± 1%
	2048 picture elements along scan line length of 255 mm ± 1%	
	2432 picture elements along scan line length of 303 mm ± 1%	
(1, 0)	1728 picture elements along scan line length of 215 mm ± 1%	2048 picture elements along scan line length of 255 mm ± 1%
	2048 picture elements along scan line length of 255 mm ± 1%	
(1, 1)	Invalid	Invalid
19, 20	Maximum recording length capability	Maximum recording length
(0, 0)	A4 (297 mm)	A4 (297 mm)
(0, 1)	Unlimited	Unlimited
(1, 0)	A4 (297 mm) and B4 (364 mm)	B4 (364 mm)
(1, 1)	Invalid	Invalid
21, 22, 23	Minimum scan line time capability of the receiver	Minimum scan line time
(0, 0, 0)	20 ms at 3.85 l/mm: $T_{7.7} = T_{3.85}$	20 ms
(0, 0, 1)	40 ms at 3.85 l/mm: $T_{7.7} = T_{3.85}$	40 ms
(0, 1, 0)	10 ms at 3.85 l/mm: $T_{7.7} = T_{3.85}$	10 ms
(1, 0, 0)	5 ms at 3.85 l/mm: $T_{7.7} = T_{3.85}$	5 ms
(0, 1, 1)	10 ms at 3.85 l/mm: $T_{7.7} = 1/2 T_{3.85}$	
(1, 1, 0)	20 ms at 3.85 l/mm: $T_{7.7} = 1/2 T_{3.85}$	
(1, 0, 1)	40 ms at 3.85 l/mm: $T_{7.7} = 1/2 T_{3.85}$	
(1, 1, 1)	0 ms at 3.85 l/mm: $T_{7.7} = T_{3.85}$	0 ms
24	Extend field	Extend field
25	2400 bit/s handshaking	2400 bit/s handshaking
26	Uncompressed mode	Uncompressed mode
27	Error correction mode	Error correction mode
28	Set to "0".	Frame size 0 = 256 octets 1 = 64 octets
29	Error limiting mode	Error limiting mode
30	Reserved for G4 capability on PSTN	Reserved for G4 capability on PSTN
31	T.6 coding capability	T.6 coding enabled
32	Extend field	Extend field
33	Validity of bits 17, 18	Recording width
(0)	Bits 17, 18 are valid	Recording width indicated by bits 17, 18
(1)	Bits 17, 18 are invalid	Recording width indicated by this field bit information
34	Recording width capability 1216 picture elements along scan line length of 151 ± mm 1%	Middle 1216 elements of 1728 picture elements
35	Recording width capability 864 picture elements along scan line length of 107 ± mm 1%	Middle 864 elements of 1728 picture elements
36	Recording width capability 1728 picture elements along scan line length of 151 ± mm 1%	Invalid
37	Recording width capability 1728 picture elements along scan line length of 107 ± mm 1%	Invalid
38	Reserved for future recording width capability.	

Bit No.	DIS/DTC	DCS
39	Reserved for future recording width capability.	
40	Extend field	Extend field
41	R8×15.4 lines/mm	R8×15.4 lines/mm
42	300×300 pels/25.4 mm	300×300 pels/25.4 mm
43	R16×15.4 lines/mm and/or 400×400 pels/25.4 mm	R16×15.4 lines/mm and/or 400×400 pels/25.4 mm
44	Inch based resolution preferred	Resolution type selection "0": neritic based resolution "1": inch based resolution
45	Metric based resolution preferred	Don't care
46	Minimum scan line time capability for higher resolutions "0": $T_{15.4} = T_{7.7}$ "1": $T_{15.4} = 1/2T_{7.7}$	Don't care
47	Selective Polling capability	Set to "0".
48	Extend field	Extend field

Note 1 - Standard facsimile units conforming to T.2 must have the following capability: Index of cooperation (IOC)=264.

Note 2 - Standard facsimile units conforming to T.3 must have the following capability: Index of cooperation (IOC)=264.

Note 3 - Standard facsimile units conforming to T.4 must have the following capability: Paper length=297 mm.

Signal	Identification Signal Format	Function
Training 1	_____	A fixed pattern is transmitted to the receiving side at a speed (2400 to 14400 bps) designated by DCS, and the receiving side optimizes the automatic equalizer, etc., according to this signal.
TCF (Training Check)	_____	Sends 0 continuously for 1.5 seconds at the same speed as the training signal.
CFR (Confirmation to Receive)	X0100001	Notifies the sending side that TCF has been properly received. If TCF is not properly received, FTT (Failure To Train) X0100010 is relayed to the sender. The sender then reduces the transmission speed by one stage and initiates training once again.
Training 2	_____	Used for reconfirming the receiving side like training 1.
Image Signal	Refer to the next page.	_____
RTC (Return to Control)	_____	Sends 12 bits ($0...01 \times 6$ times) to the receiver at the same speed as the image signal and notifies completion of transmission of the first sheet.
EOP (End of Procedure)	X1110100	End of one communication
MCF (Message Confirmation)	X0110001	End of 1 page reception
DCN (Disconnect)	X1011111	Phase E starts.
MPS (Multi-Page Signal)	X1110010	Completion of transmission of 1 page. If there are still more documents to be sent, they are output instead of EOP. After MCF reception, the sender transmits an image signal of the second sheet.
PRI-EOP (Procedural Interrupt-EOP)	X1111100	If there is an operator call from the sender, it is output after RTC.
PIP (Procedural Interrupt Positive)	X0110101	This is output when an operator call is received.

b. Redundancy Compression Process Coding Mode

This unit uses one-dimensional MH format.

Modified Huffman (MH) Code		
Run length	Code for White Line	Code for Black Line
0	00110101	000011011
1	000111	010
2	0111	11
3	1000	10
4	1011	011
5	1100	0011
6	1110	0010
7	1111	00011
8	10011	000101
9	10100	000100
10	00111	0000100
11	01000	0000101
12	001000	0000111
13	000011	00000100
14	110100	00000111
15	110101	000011000
16	101010	0000010111
17	101011	0000011000
18	0100111	0000001000

(a) Document

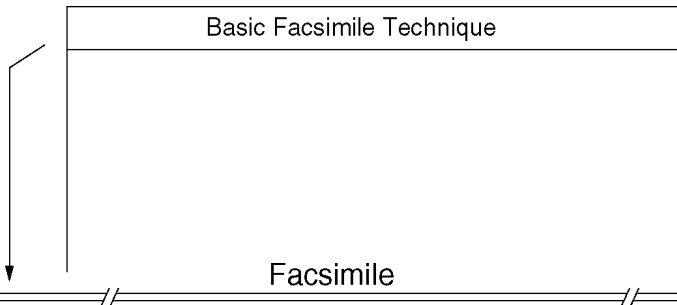

(b) Part of document

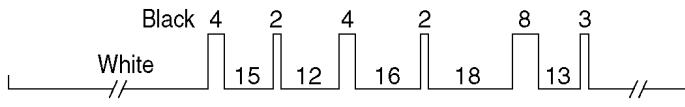

(c) Run length and image signals equivalent to (b)

(d) Codification of (c) according to MH formula

00110111101010 (White 400) 011 (Black 4) 110101 (White 15) 11 (Black 2) 001000 (White 12) 011 (Black 4) 101010 (White 16)

11 (Black 2) 0100111 (White 18) 000101 (Black 8) 000011 (White 13) 10 (Black 3)

(c) Total bit number before MH codification (497 bit)

(d) Total bit number after MH codification (63 bit)

6.6.2. Modem Circuit Operation

The modem (IC505) has all the hardware satisfying the CCITT standards mentioned previously.

When the ASIC IC501 (61) is brought to a low level, the modem (IC505) is chip-selected and the resistors inside IC are selected by the select signals from ASIC (IC501) ADR0-ADR4. The commands are written through the data bus, and all the processing is controlled by the ASIC (IC501) according to CCITT procedures. The INT signal dispatched from IRQn (pin 100 of IC505) to ASIC (IC501) when the transmission data is accepted and the received data is demodulated, the ASIC (IC501) implements post processing. This modem (IC505) has an automatic application equalizer.

With training signal 1 or 2 during G3 reception, it can automatically establish the optimum equalizer. The modem (IC505) operates using the 32.256 MHz clock (X503).

1. Facsimile Transmission

The digital image data on the data bus is modulated in the modem (IC505), and sent from pin 56 via Analogue SW IC508, amplifier IC511 and the NCU section to the telephone line.

Refer to **Check Sheet for Signal Route** (P.123).

2. Facsimile Reception

The analogue image data which is received from the telephone line passes through the NCU section and enters pin 47 of the modem (IC505). The signals that enter pin 47 of the modem (IC505) are demodulated in the board to digital image signals, then placed on the data bus.

In this case, the image signals from the telephone line are transmitted serially. Hence, they are placed on the bus in 8 bit units. Here, the internal equalizer circuit reduces the image signals to a long-distance receiving level.

This is designed to correct the characteristics of the frequency band centered about 3 kHz and maintain a constant receiving sensitivity. It can be set in the service mode.

Refer to **Check Sheet for Signal Route** (P.123).

3. DTMF Transmission (Monitor tone)

The DTMF signal generated in the modem (IC505) is output from pin 56, and is then sent to the circuit on the same route as used for facsimile transmission.

Refer to **Check Sheet for Signal Route** (P.123).

(DTMF Monitor Tone)

Refer to **Check Sheet for Signal Route** (P.123).

4. Call Tone Transmission

This is the call signal which is generated in the ASIC (IC501) and sent to the speaker.

Refer to **Check Sheet for Signal Route** (P.123).

5. Busy/Dial Tone Detection

The path is the same as FAX receiving. When it is detected, the carrier detect bit of the resistor in the modem (IC505) becomes 1, and this status is monitored by the ASIC (IC501).

6. Caller ID Detection

The caller ID signal which is received from the telephone line/passes through IC101 pin (2-1). And it enters pin 50 of the modem (IC505).

6.7. NCU Section

6.7.1. General

NCU is the interface with the telephone line. It is composed of Bell detection circuit, Pulse dial circuit, Line amplifier and sidetone circuits. The following is a brief explanation of each circuit.

6.7.2. EXT. TEL. Line Relay (RL101)

1. Circuit Operation

Normally, this relay switches to the external telephone side (break) and switches to the tel line side (make) while OFF-HOOK.

{ IC501 (130) High Level → CN507 (14) High Level } → CN101 (14) High Level → Q111 ON → RLY101 (make)

6.7.3. Bell Detection Circuit

1. Circuit Operation

The signal waveform for each section is indicated below. The signal (low level section) input to pin 23 of ASIC IC501 on the digital board is illustrated.

Between the Tip and Ring

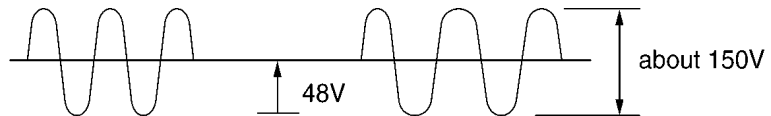

Between PC103 (1) and (2)

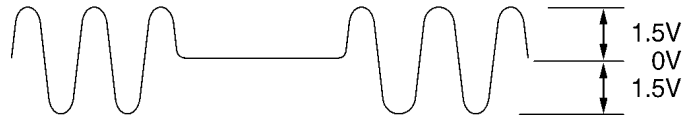

PC103 (4)/ASIC IC501 (23)

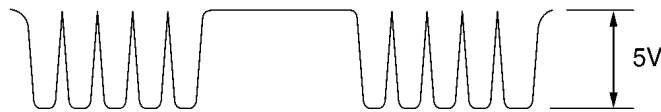

TEL LINE → PC103 (1, 2 → 4) → IC501 (23): Bell

6.7.4. Pulse Dial Circuit and ON/OFF Hook Circuit

IC501 (130) → LOW LEVEL (MAKE) → Q111 ON (MAKE) → RL101 ON (MAKE) → TEL LINE

IC501 (130) → HIGH LEVEL (BREAK) → Q111 OFF (BREAK) → RL101 OFF (BREAK) → TEL LINE

6.7.5. Line Amplifier and Side Tone Circuit

1. Circuit Operation

The reception signal output from the line transformer T101 is input to pin (2) of IC101 via C110 and R109 and then the signal is amplified at pin (2) of IC101 and sent to the reception system at 0dB.

The transmission signal is output from CN101 (6) and transmitted to T101 via R120 and R119. If the side tone circuit is not applied, the transmission signal will return to the reception amplifier via C110 and R109. When the side tone circuit is active, the signal output from IC101 pin (1) passes through R114, R113, C113 and R112 and goes into the amplifier IC101 pin (3). This circuit is used to cancel the transmission return signal.

Side Tone Circuit

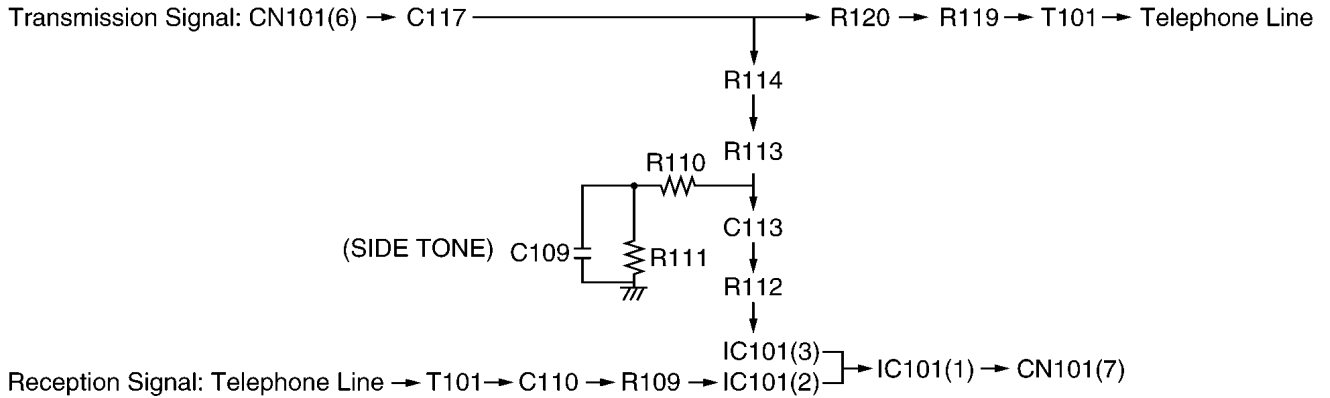

6.7.6. Calling Line Identification Circuit

1. Function

This unit is compatible with the Caller ID service offered by your local telephone company. To use this feature, you must subscribe to a Caller ID service. The data for the Caller ID from the telephone exchange is sent during the interval between the first and second rings of the bell signal. The data from the telephone exchange is a modem signal which is modulated in an FSK (Frequency Shift Keying) format. Data "0" is a 1200 Hz sine wave, and data 1 a 2200 Hz sine wave.

There are two type of the message format which can be received: i.e. the single data message format and multiple data message format.

The multiple data format allows to transmit the name and data code information in addition to the time and telephone number data.

When there is multiple data in the unit, the name or telephone number are displayed.

2. Circuit Operation:

The Caller ID signal input from TEL LINE is processed with MODEM (IC505).

Refer to **Check Sheet for Signal Route** (P.123) for the route of Caller ID signal.

Timing Chart

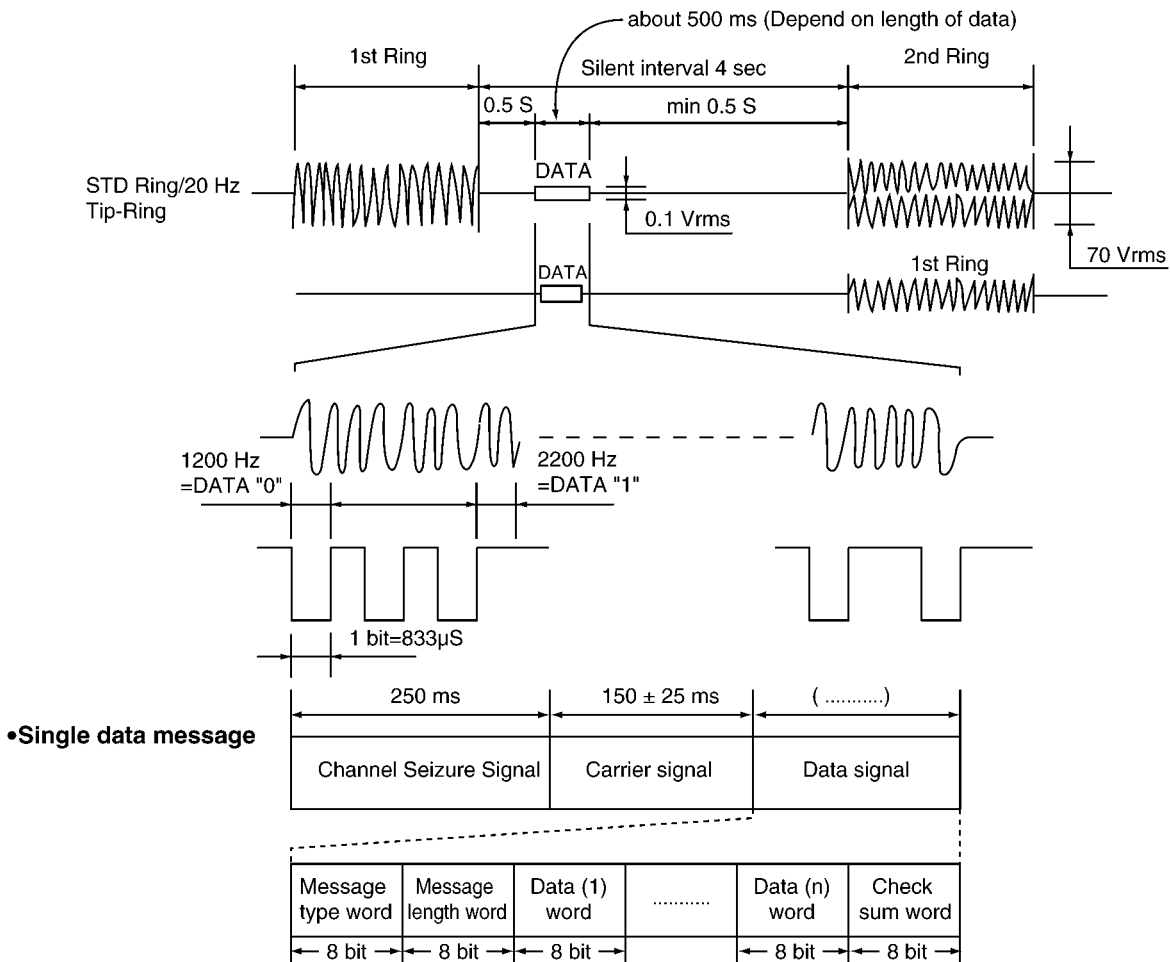

- 1 word = All 8 bit data
- Message Type Word = Fixed value "00000100"
- Message Length Word = number of the data word
- Data word = The data value (month, day, hour, minute, telephone number)

· Multiple data message

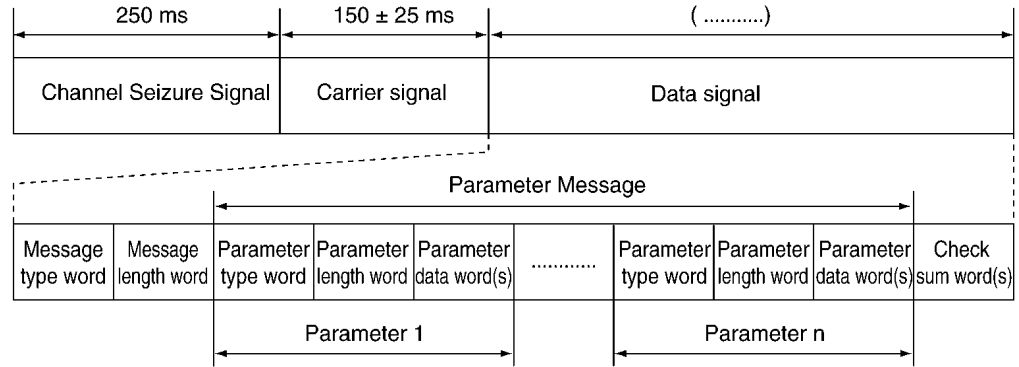

- 1 word = All 8 bit data
- Message Type = Fixed value "10000000"
- Message Length Word = number of the Parameter Message word
- Parameter Type Word = Kind of data (ex. the time, phone number)
- Parameter Length Word = number of the Parameter data word
- Parameter Word (s) = the data value

6.8. ITS (Integrated telephone System) and Monitor Section

6.8.1. General

The general ITS operation is performed by the special IC505 which has a handset circuit. The alarm tone, the key tone, and the beep are output from the ASIC IC501 (digital board). During the pulse dial operation, the monitor tone is output from the ASIC IC501.

6.8.2. Telephone Monitor (KX-FP207)

1. Function

This is the function when you are not holding the handset and can hear the caller's voice from the line.

2. Signal path

Refer to **Check Sheet for Signal Route** (P.123).

6.8.3. Speakerphone Circuit (KX-FP218)

1. Function

The circuit controls the automatic switching of the transmitted and received signals, to and from the telephone line, when the unit is used in the hands-free mode.

2. Circuit Operation

The speakerphone can only provide duplex.

3. Signal path

Refer to **Check Sheet for Signal Route** (P.123).

6.8.4. Handset Circuit

1. Function

This circuit controls the conversation over the handset, i.e. the transmitted and received voices to and from the handset.

2. Signal path

Refer to **Check Sheet for Signal Route** (P.123).

6.8.5. Monitor Circuit for Each Signals

1. Function

This circuit monitors various tones, such as **1** DTMF tone, **2** Alarm/Beep/Key tone/Bell.

2. Signal path

Refer to **Check Sheet for Signal Route** (P.123).

6.9. Operation Board Section

The unit consists of a LCD (Liquid crystal display), KEYS and LEDs (light-emitting diodes). They are controlled by the Gate Array (IC301) and ASIC (IC501: on the Digital BOARD).

The key matrix table is shown below.

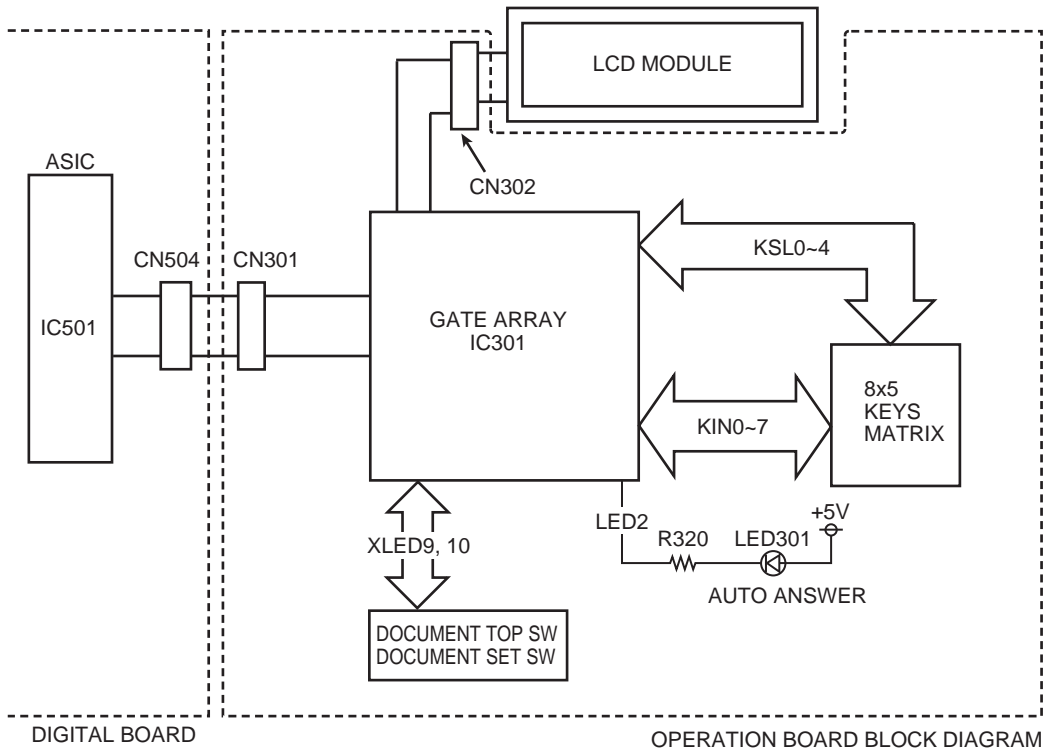

Key Matrix

	KIN0	KIN1	KIN2	KIN3	KIN4	KIN5	KIN6	KIN7
KSL0	SW327 REDIAL/PAUSE	SW331 CALLER ID	SW323 3	SW319 2	SW315 1	SW311 →	(SW306) ERASE	SW301 ←
KSL1	SW328 R	SW332 STOP	SW324 6	SW320 5	SW316 4	SW312 ↑	(SW307) MEMO	SW302 BROADCAST
KSL2	SW329 MUTE	SW333 COPY	SW325 9	SW321 8	SW317 7	SW313 SET	(SW308) CHECK	SW303 PRINT REPORT
KSL3	/	/	/	/	/	/	(SW310) PLAYBACK	SW305 AUTO ANSWER
KSL4	SW330 MONITOR (FP207) SP-PHONE (FP218)	SW334 FAX/START	SW326 #	SW322 0	SW318 *	SW314 ↓	(SW309) REC	SW304 MENU

SW306~310 are for KX-FP218.

XLED

	XLED10	XLED9
	DOCUMENT SET	DOCUMENT TOP

LED

	LED2	LED3	LED4
	AUTO ANSWER	/	/

6.10. LCD Section

The Gate Array (IC301) works only for writing the ASCII code from the data bus (D4~D7). V0 is supplied for the crystal drive. R310, R311, R312 and R314 are density control resistors.

Consequently, in this unit, the timing (positive clock) is generated by the LCD interface circuitry in the gate array (IC301).

Circuit Diagram

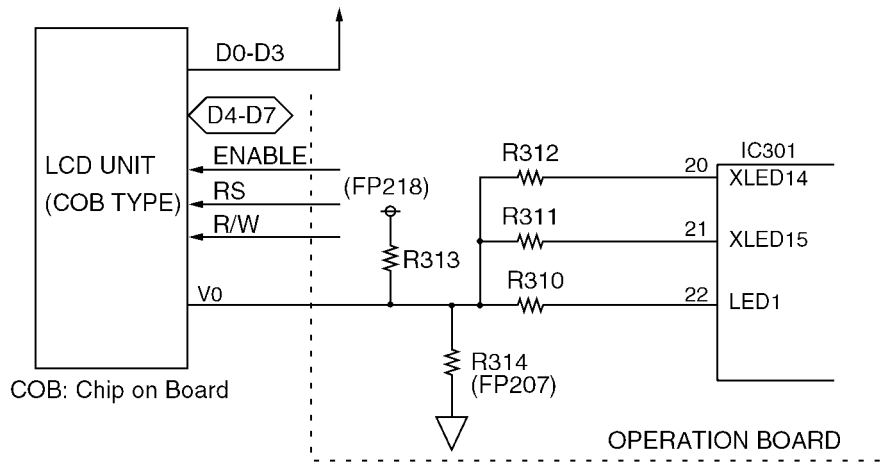

Timing Chart

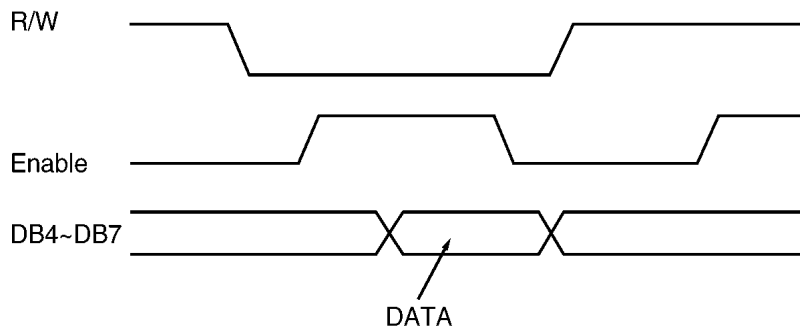

Display mode	Density	Normal	Dark
2 lines (X1.0)	LED1 (IC301-22pin)	H	L
	XLED15 (IC301-21pin)	L	L
	XLED14 (IC301-20pin)	Hi-Z	L
X1.5	LED1	H	H
	XLED15	Hi-Z	L
	XLED14	Hi-Z	Hi-Z

6.11. Power Supply Board Section

This power supply board uses the switching regulator method.

Block Diagram

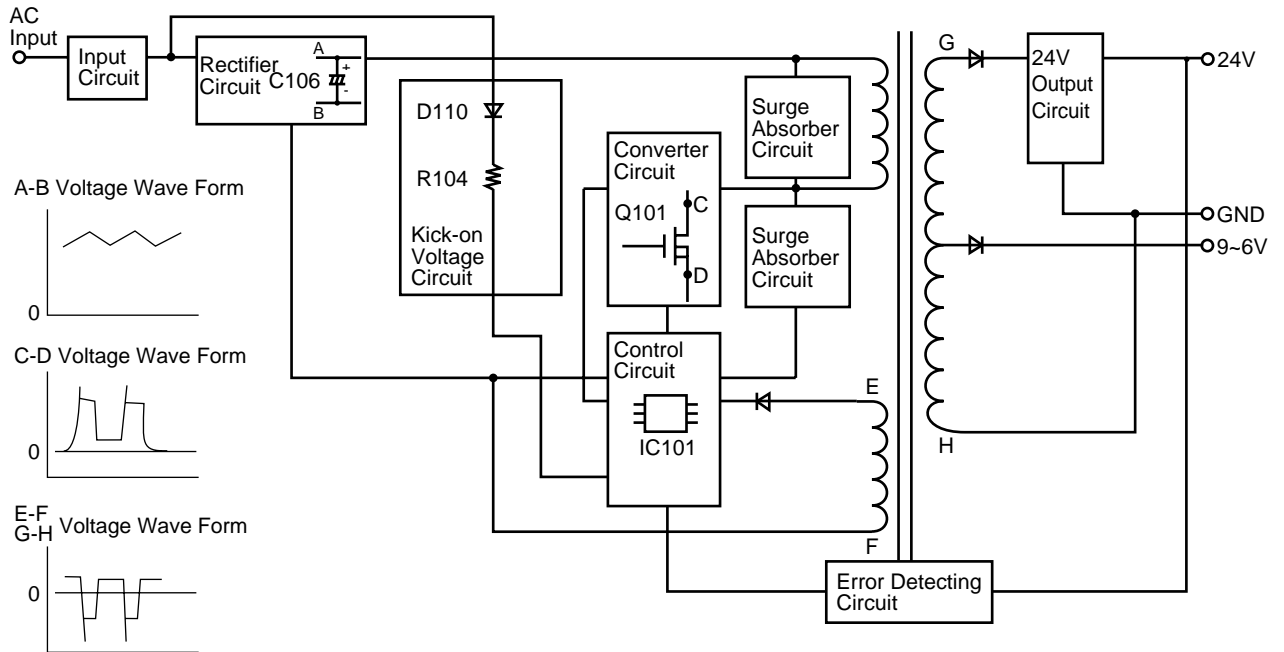

[Input Circuit]

The input current goes into the input rectifier circuit through the filter circuit. The filter circuit decreases the noise voltage and the noise electric field strength.

[Rectifier Circuit]

The input current is rectified by D101, D102, D103 and D104 and charges C106 to make DC voltage. Then it supplies power to the converter circuit.

[Kick-on voltage circuit]

Bias is applied to the Q101 gate via this circuit when the AC power is turned on and Q101 begins operating.

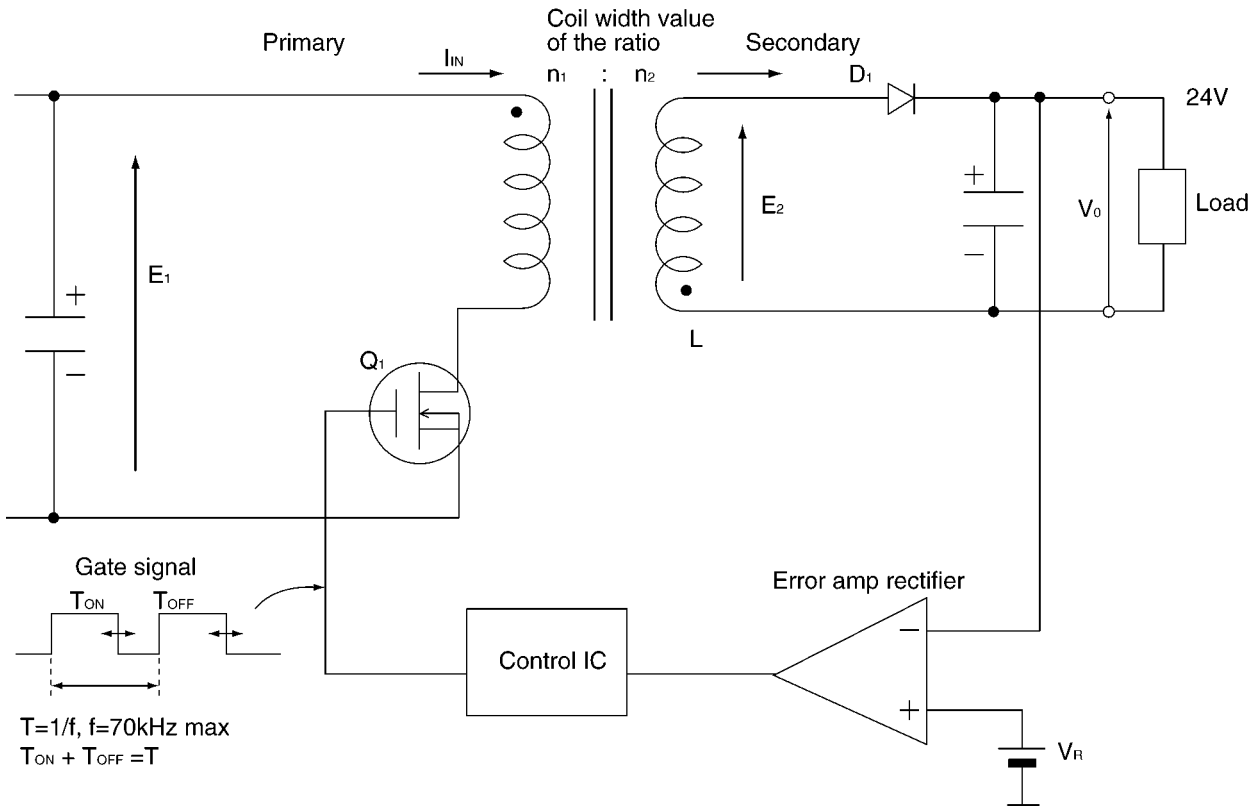

The following is an overview of how the power supply unit is controlled.
The control method of this power supply unit is pulse width modulation.

When Q_1 is ON, the energy is charged in the transfer primary coil according to E_1 . When Q_1 is OFF, the energy is output from the secondary transfer as follows.

$L \rightarrow D_1 \rightarrow \text{Load} \rightarrow L$

Then the power is supplied to the Load. When Q_1 is ON, power is not output from the secondary side. The output voltage is fed back in the control IC according to the error amp rectifier. Then depending on how T_{ON} is controlled, stabilization occurs. Also, when the current load becomes too large, in order to decrease the voltage output, the increase in τ is controlled and the output voltage is stabilized.

Therefore, basically the timing: T_{on}/T_{off} of Q_1 controls the output voltage.

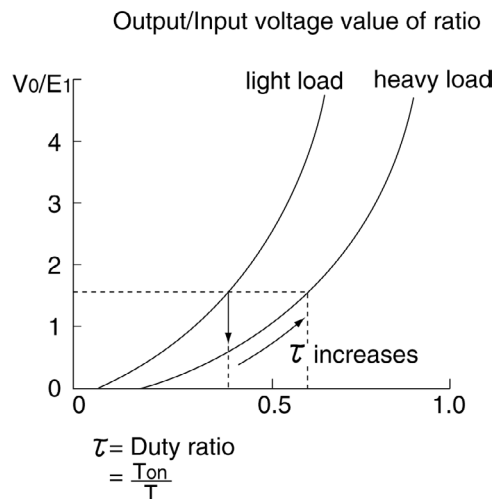

[Surge Absorber Circuit]

This circuit is for absorbing surge voltage generated by the transformer.

[Control Circuit and Detecting Circuit]

The control circuit amplifies the output with increased voltage detected in the error detecting circuit. Then it drives the main transistor.

In this power supply, the duty ratio is defined by changing the ON period of the main transistor.

This is shown as follows.

When the output voltage of the 24V circuit increases, the current of the photo coupler PC101 increases, the pulse width of the output control IC becomes narrower and the ON period of Q101 becomes shorter.

[Over Current Limiter (O.C.L)]

The highest drain current (Q101) is limited by a limiter circuit (IC101) of 24V. The 24V output is limited by this circuit.

[Over Voltage Circuit]

If the 24V output increases because the error detecting circuit or control circuit is broken, IC101 will recognize this signal and output becomes 0V.

Dummy load method (to quickly check the power supply output)

Refer to **Power Supply Board Section** (P.128).

7 Location of Controls and Components

7.1. Overview

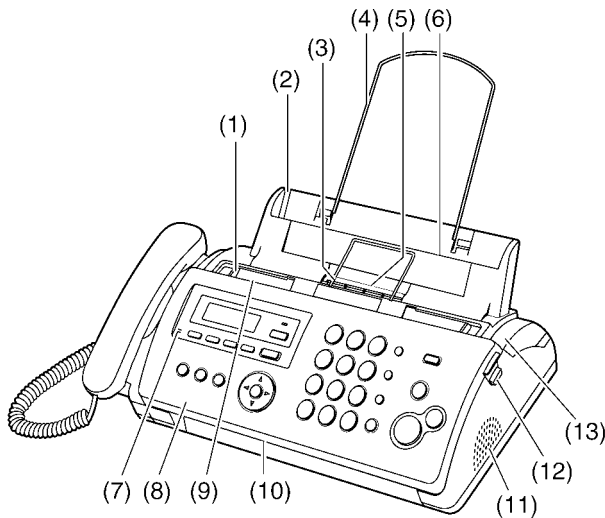

* The pictured model is KX-FP218.

- (1) Document guides
- (2) Paper tray
- (3) Metal recording paper guide
- (4) Paper support
- (5) Recording paper exit
- (6) Recording paper entrance
- (7) Microphone (KX-FP218 only)
- (8) Front cover
- (9) Document entrance
- (10) Document exit
- (11) Speaker
- (12) Green button (Back cover release button)
- (13) Back cover

7.2. Control Panel

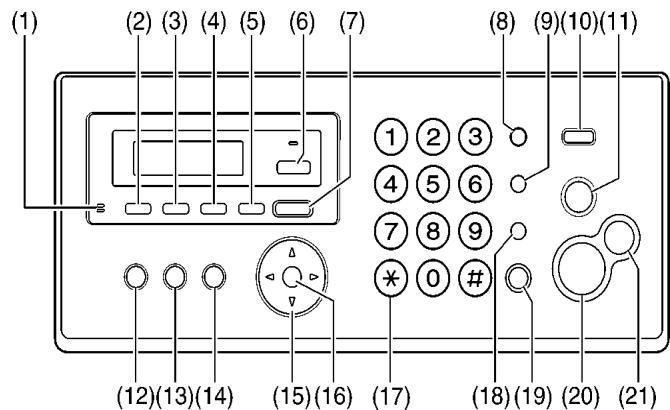

- (1) **[MIC] (Microphone) (KX-FP218 only)**
 - The built-in microphone.
- (2) **[GREETING REC] (KX-FP218 only)**
 - To record a greeting message.
- (3) **[GREETING CHECK] (KX-FP218 only)**
 - To check a greeting message.
- (4) **[MEMO] (KX-FP218 only)**
 - To record a memo message.
- (5) **[ERASE] (KX-FP218 only)**
 - To erase messages.
- (6) **[AUTO ANSWER]**
 - To turn the auto answer setting ON/OFF.
- (7) **[PLAYBACK] (KX-FP218 only)**
 - To play messages.
- (8) **[REDIAL] [PAUSE]**
 - To redial the last number dialed. If the line is busy when you make a call using the **[MONITOR]** (KX-FP207)/**[SP-PHONE]** (KX-FP218) button, or when you send a fax, the unit will automatically redial the number 2 or more times.
 - To insert a pause during dialling.
- (9) **[R]**
 - To access special telephone services or for transferring extension calls.
 - The recall time can be changed.
- (10) **[CALLER ID]**
 - To use Caller ID features.
- (11) **[STOP]**
 - To stop an operation or programming session.
 - To erase a character/number. Press and hold to erase all characters/numbers.
- (12) **[BROADCAST]**
 - To send a document to multiple parties.
- (13) **[PRINT REPORT]**
 - To print reference lists and reports.
- (14) **[MENU]**
 - To start or exit programming.
- (15) **[PHONEBOOK] [VOLUME]**
 - To adjust volume.
 - To search for a stored item.
- (16) **[SET]**
 - To store a setting during programming.

(17) [TONE]

- To change from pulse to tone temporarily during dialling when your line has rotary pulse service.

You can also use tone dial service by changing feature #13. (Refer to Program Mode Table (P.98).)

(18) [MUTE]

- To mute your voice during a conversation. Press again to resume the conversation.

(19) [SP-PHONE] (KX-FP218)

- For speakerphone operation.

(19) [MONITOR] (KX-FP207)

- To initiate dialling without lifting the handset.

(20) [FAX START]

- To send or receive a fax.

(21) [COPY]

- To copy a document.

8 Installation Instructions

8.1. Installation Space

The space required to install the unit is shown below.

The dimensions given are necessary for the unit to operate efficiently. (When the recording paper is not inserted to the unit.)

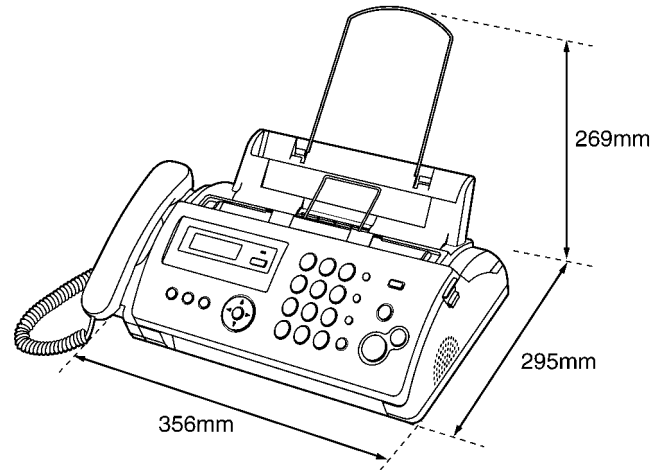
**Note:**

- Avoid excessive heat or humidity.
- Use the unit within the following ranges of temperature and humidity.
- Ambient temperature: 5°C to 35°C
- Relative humidity: 20% to 80% (without condensation)
- Avoid direct sunlight.
- Do not install near devices which contain magnets or generate magnetic fields.
- Do not subject the unit to strong physical shock or vibration.
- Keep the unit clean. Dust accumulation can prevent the unit from functioning properly.
- To protect the unit from damage, hold both sides when you move it.

8.2. Connections

Caution:

- When you operate this product, the power outlet should be near the product and easily accessible.
- Be sure to use the telephone line cord included in this unit.
- Do not extend the telephone line cord.

- ① Telephone line cord
 - Connect to a single telephone line jack.
- ② Power cord
 - Connect to a power outlet (220 - 240 V, 50 / 60 Hz).
- ③ [EXT] jack
 - You can connect an answering machine or a telephone. Remove the stopper if attached.
- ④ Extension telephone (not included)

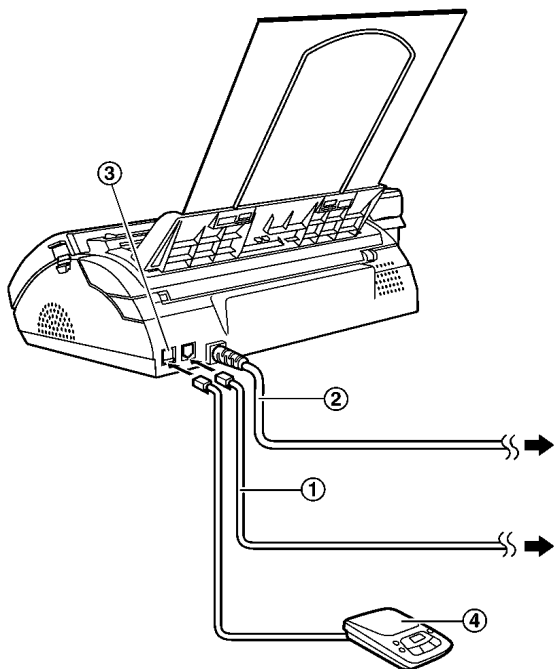

Note:

- To avoid malfunction, do not position the fax machine near appliances such as TVs or speakers which generate an intense magnetic field.
- If any other device is connected to the same telephone line, this unit may disturb the network condition of the device.

- If you use the unit with a computer and your internet provider instructs you to install a filter (⑤), please connect it as follows.

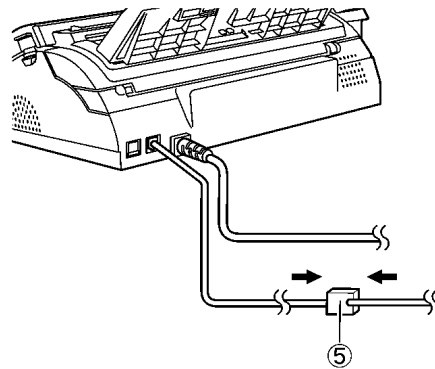

8.3. Installing the Ink Film

1. Open the front cover.

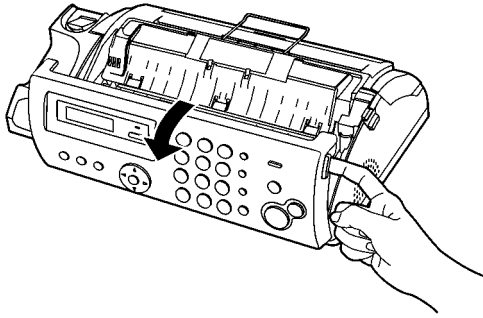

2. Release the back cover by pushing the green button (①).

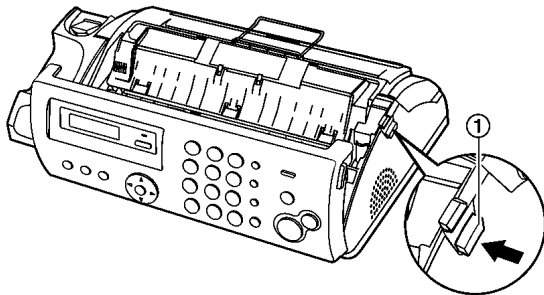

3. Open the back cover.

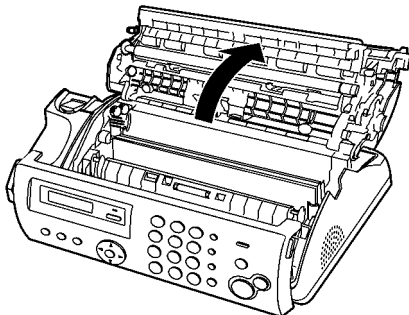

4. Insert the blue gear of the ink film roll into the front left slot of the unit (②) and the white gear of the ink film roll into the rear left slot of the unit (③).

- The ink film is safe to touch and will not rub off on your hands like carbon paper.

- Make sure the blue gear (②) and white gear (③) are installed as shown.

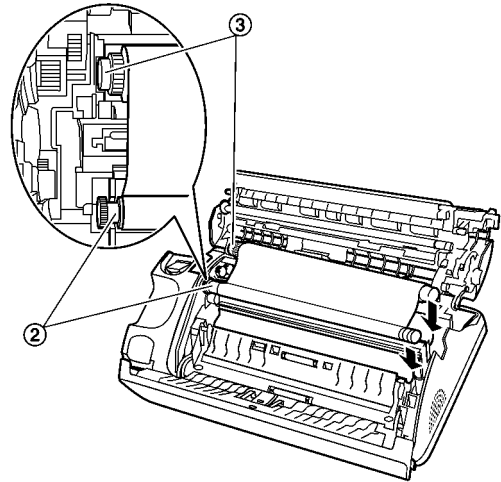

5. Turn the blue gear (④) in the direction of the arrow until the ink film is tight (⑤) and at least one layer of ink film is wrapped around the blue core (⑥).

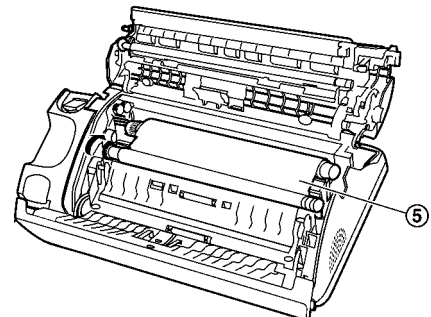
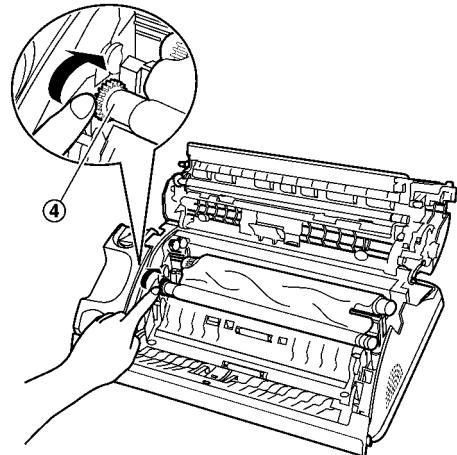

Correct

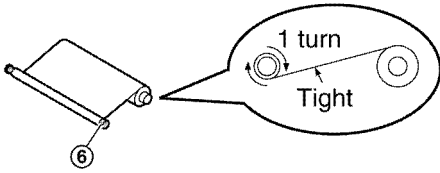

Incorrect

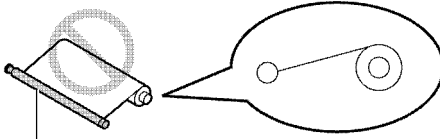

No ink film is wrapped around the blue core.

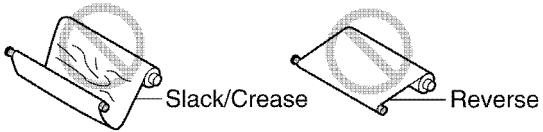

6. Close the back cover securely by pushing down on the dotted area at both ends (7).

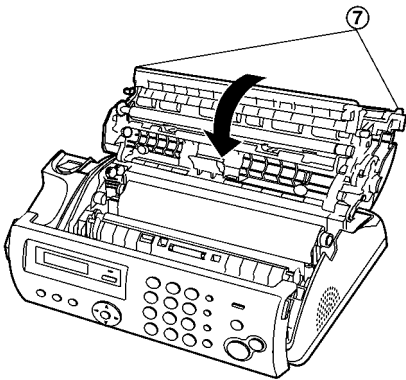

7. Close the front cover securely.

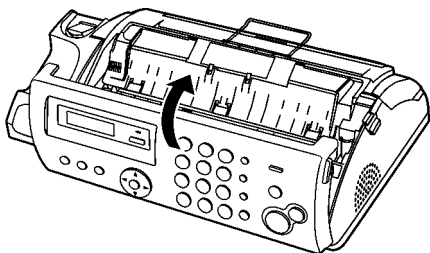

8.4. Installing the Paper Tray

Pull up the metal recording paper guide (1), then install the paper tray (2).

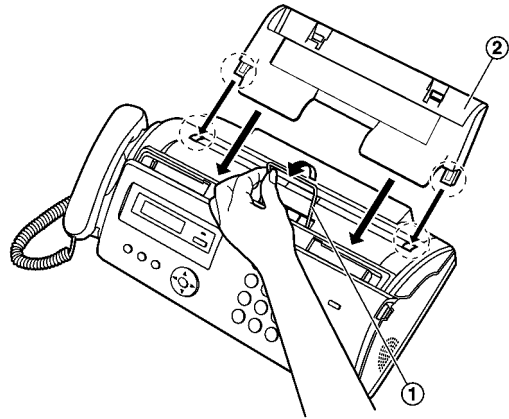

• Make sure the arrows on the paper tray and the unit match.

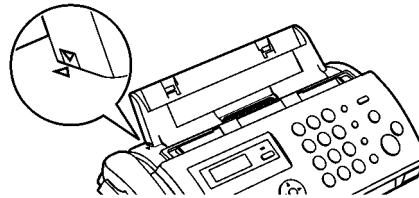

8.5. Paper Support

Hold open the paper support (①), then insert the ends into the holes on the paper tray (②).

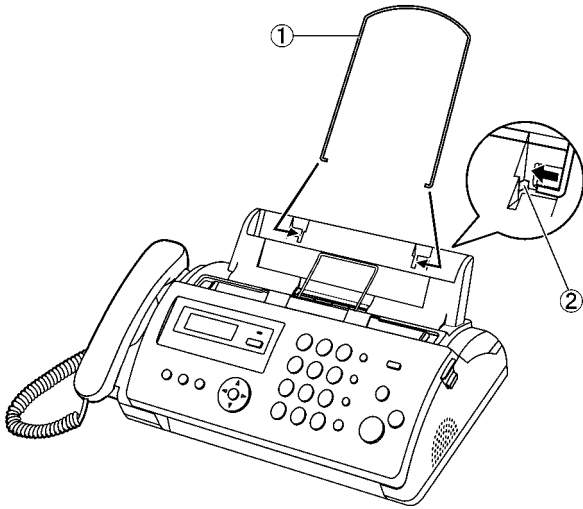

8.6. Installing the Recording Paper

The unit can hold up to 20 sheets of 64 g/m² to 80 g/m² paper.

1. Fan the paper to prevent paper jams.

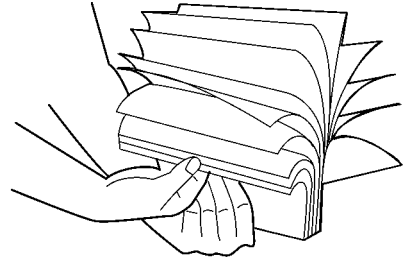

2. Insert the paper gently, print-side down (①).
 - Do not force the paper into the paper tray.

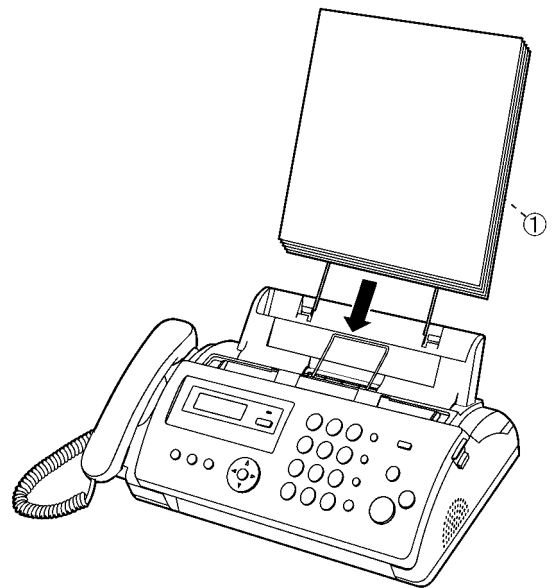

- If the paper is not inserted correctly, remove all of the installed paper, and re-install it gently. Otherwise the paper may jam.

Correct

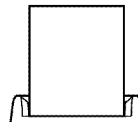

Incorrect

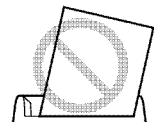

Note:

- Remove all of the installed paper before adding paper.

Document requirements

Minimum document size

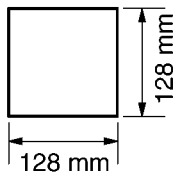

Maximum document size

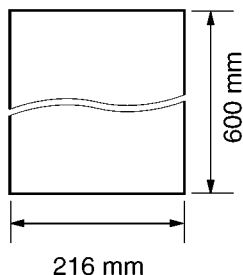

Effective scanning area

• Shaded area will be scanned.

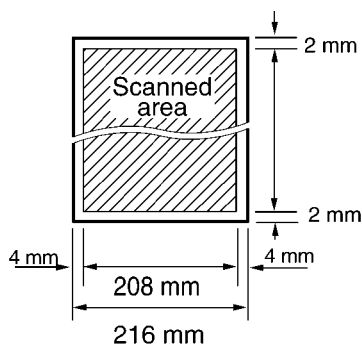

Document weight

- When faxing a single sheet:
45 g/m² to 90 g/m²
- When faxing a multiple sheet:
60 g/m² to 80 g/m²

Note:

- Remove chips, staples or other fasteners.
- Do not send the following types of documents. (Make a copy of the document and send the copy.)
 - Chemically treated paper such as carbon or carbonless duplicating paper
 - Electrostatically charged paper
 - Badly curled, creased or torn paper
 - Paper with a coated surface
 - Paper with a faint image
 - Paper with printing on the opposite side that can be seen through the other side, such as newspaper
- Check that ink, paste or correction fluid has dried completely.
- To send a document with a width of less than 210 mm, we recommend using a copy machine to copy the original document onto A4 or letter-sized paper, then sending the copied document.

9 Operation Instructions

9.1. Setting Your Logo

You can program your logo (name, company name, etc.) so that it appears on the top of each page sent.

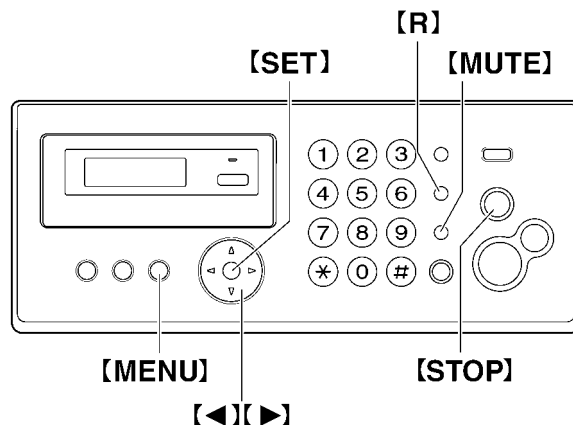

1. [MENU] → [#][0][2] → [SET]

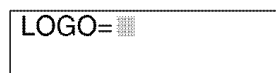

2. Enter your logo, up to 30 characters. See the following character table for details. → [SET]
3. Press [MENU] to exit.

To select characters with the dial keypad

Keypad	Characters
[1]	Space # & ' () * , - . / 1
[2]	a b c A B C 2
[3]	d e f D E F 3
[4]	g h i G H I 4
[5]	j k l J K L 5
[6]	m n o M N O 6
[7]	p q r s P Q R S 7
[8]	t u v T U V 8
[9]	w x y z W X Y Z 9
[0]	0 (Space)
[*]	To switch between uppercase or lowercase letters.
[R]	Hyphen.
[MUTE]	To insert a space.
[STOP]	To delete a character.

Note:

- To enter a character that is located on the same dial key as the previously entered character, you must first press [▶] to move the cursor to the next space.

To enter your logo**Example:** "BILL"

1. Press **[2]** 2 times.

LOGO=B

2. Press **[4]** 3 times.

LOGO=BI

3. Press **[5]** 3 times.

LOGO=BI

4. Press **[▶]** to move the cursor to the next space and press **[5]** 3 times.

LOGO=BIL

To switch between uppercase or lowercase letters

Pressing the **[*]** button will change the letter input to uppercase or lowercase alternately.

1. Press **[2]** 2 times.

LOGO=B

2. Press **[4]** 3 times.

LOGO=BI

3. Press **[*]** 3 times.

LOGO=Bi

4. Press **[5]** 3 times.

LOGO=Bi

To correct a mistake

Press **[◀]** or **[▶]** to move the cursor to the incorrect character, and make the correction.

- To erase all of the characters, press and hold **[STOP]**.

10 Test Mode

The codes listed below can be used to perform simple checks for some of the unit's functions. When complaints are received from customers, they provide an effective tool for identifying the locations and causes of malfunctions. To do this, you set the Service mode (Refer to **Operation Flow** (P.62).) first, then operate the below test items.

Test Mode	Type of Mode	Code	Function
		Operation after code input	
MEMORY CLEAR	Service Mode	"5" "5" "0"	Refer to Memory Clear Specification (P.66).
		SET	
FLASH MEMORY CHECK	Service Mode	"5" "5" "1"	Indicates the version and checks the sum of the FLASH MEMORY.
		SET	
DTMF SINGLE TEST	Service Mode	"5" "5" "2"	Outputs the DTMF as single tones. Used to check the frequencies of the individual DTMF tones. Refer to DTMF Signal Tone Transmit Selection (P.59).
		1...ON 2...OFF	
MODEM TEST (KX-FP207)	Service Mode	"5" "5" "4"	Telephone line circuit is connected automatically, output the following signals on the circuit line. 1) OFF 2) 9600bps 3) 7200bps 4) 4800bps 5) 2400bps 6) 300bps 7) 2100Hz 8) 1100Hz
		SET	
MODEM TEST (KX-FP218)	Service Mode	"5" "5" "4"	Telephone line circuit is connected automatically, output the following signals on the circuit line. 1) OFF 2) 14400bps 3) 12000bps 4) 96V17 5) 72V17 6) 9600bps 7) 2000bps 8) 4800bps 9) 2400bps 10) 300bps 11) 2100Hz 12) 1100Hz
		SET	
SCAN CHECK	Service Mode	"5" "5" "5"	Turns on the LEDs of the CIS and operates the read systems.
MOTOR TEST	Service Mode	"5" "5" "6"	Rotates the transmission and reception motor to check the operation of the motor. 00: Stop 02: TX 05: Pickup 08: Rx 10: Copy 11: Assist 13: Home position • Press [STOP] button to quit.
		SET	
LED CHECK	Service Mode	"5" "5" "7"	All LEDs above the operation panel board flash on and off, or are illuminated.
LCD CHECK	Service Mode	"5" "5" "8"	Checks the LCD indication. Illuminates all the dots to check if they are normal.
		SET	
KEY CHECK	Service Mode	"5" "6" "1"	Checks the button operation. Indicates the button code on the LCD while the button is pressed. Refer to Button Code Table (P.60).
		START (any key)	
MEMORY CLEAR (except History data)	Service Mode	"7" "1" "0"	Refer to Memory Clear Specification (P.66).
		SET	
VOICE PROMPT CHECK (KX-FP218)	Service Mode	"7" "8" "4"	You can hear the voice prompt from speaker after pressing .SET. key.
		SET	

Test Mode	Type of Mode	Code	Function
		Operation after code input	
SENSOR CHECK & VOX CHECK	Service Mode	"8" "1" "5"	<p>If you enter this mode and operate sensor levers with your hands, the LCD display of the related sensor (or switch) turns ON / OFF. Also, when copying a document, the related sensor will turn ON / OFF. (Do, Sn, Co, Mo, Pt, Ri, Vx)</p> <p>For each sensor's operation, refer to Sensors and Switches (P.29).</p> <p><u>Do Sn Co Mo Pt Ri Vx</u>: LCD DISPLAY</p> <p>Do: Document set sensor :Turns on when the front cover is opened and a document is inserted.</p> <p>Sn: Read position sensor. :Turned on when the front cover is opened and starts to read a document.</p> <p>Co: Cover open sensor :Turned off when the cover is opened.</p> <p>Mo: Motor home position sensor :A home position detection sensor that is used when shifting the motor mode.</p> <p>Pt: Paper top sensor :Turned on when the cover is opened and detects a recording paper on the right side end.</p> <p>Ri: Film sensor :Turned off when the film are run out.</p> <p>Vx: Vox signal :Detection signal for the tone on the line. Turns on when there is a tone signal on the line.</p> <ul style="list-style-type: none"> • Press [STOP] button to quit.
DIGITAL SPEAKERPHONE RX & TX CHECK (KX-FP218)	Service Mode	"8" "4" "1"	Please refer to Digital Speakerphone (KX-FP218) (P.126)
		SPEAKERPHONE	
PRINT TEST PATTERN	Service Mode	"8" "5" "2"	<p>Prints out the test pattern.</p> <p>Used mainly at the factory to test the print quality.</p> <p>You can select 1~4. (See Print Test Pattern (P.61))</p>

Note:

The numbers in the boxes (XXX) indicate the keys to be input for the various test modes.

10.1. DTMF Signal Tone Transmit Selection

When set to ON (=1), the 12 keys and transmission frequencies are as shown.

key	High Frequency (Hz)	key	Low Frequency (Hz)
"1"	697	"5"	1209
"2"	770	"6"	1336
"3"	852	"7"	1477
"4"	941	"8"	1633

When set to OFF (=2), the 12 keys and transmission frequencies are as shown.

High (Hz) Low (Hz)	1209	1336	1477
697	"1"	"2"	"3"
770	"4"	"5"	"6"
852	"7"	"8"	"9"
941	"✕"	"0"	"#"

Note:

After performing this check, do not forget to turn the setting off. Otherwise, dialling in DTMF signal will not work.

10.2. Button Code Table

Code	Button Name	Code		Code	Button Name
00	NO INPUT	1F	[◀]	31	1
01	STOP	20	MENU	32	2
04	FAX START	22	PRINT REPORT	33	3
06	COPY	25	[+] VOLUME	34	4
08	MONITOR (FP207)	26	[-] VOLUME	35	5
08	SP-PHONE (FP218)			36	6
09	BROADCAST			37	7
0A	MUTE			38	8
0C	AUTO ANSWER			39	9
0D	SET			3A	0
12	REC			3B	*
14	MEMO			3C	#
15	CHECK			3D	REDIAL / PAUSE
16	ERASE			3E	R
18	PLAYBACK				
1E	[▶]			47	CALLER ID

10.3. Print Test Pattern

1. Platen roller

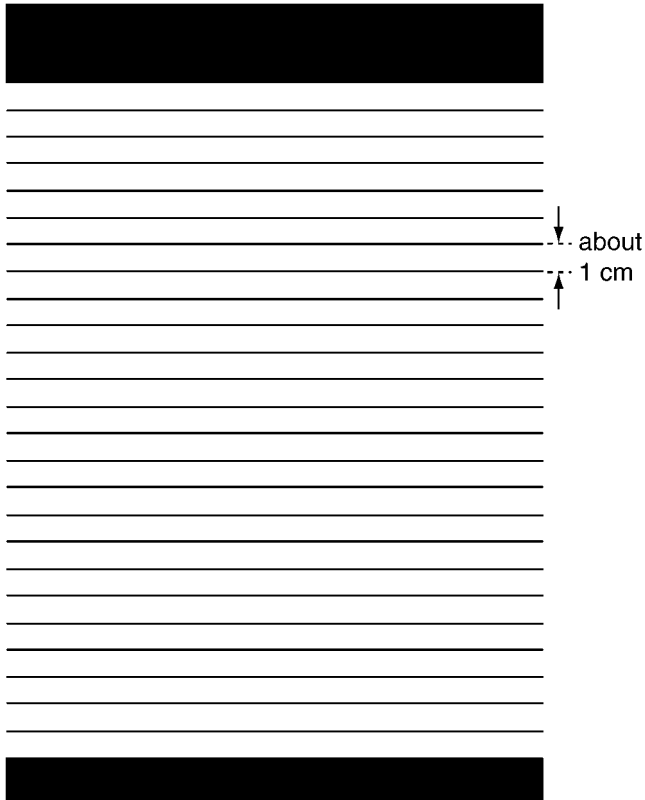

3. Thermal head 1 dot

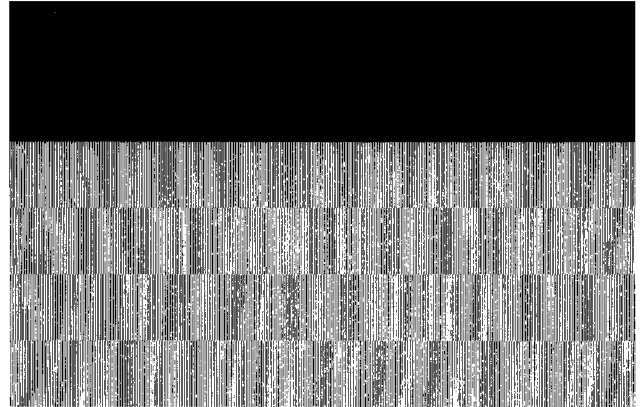

2. Left margin / Top margin

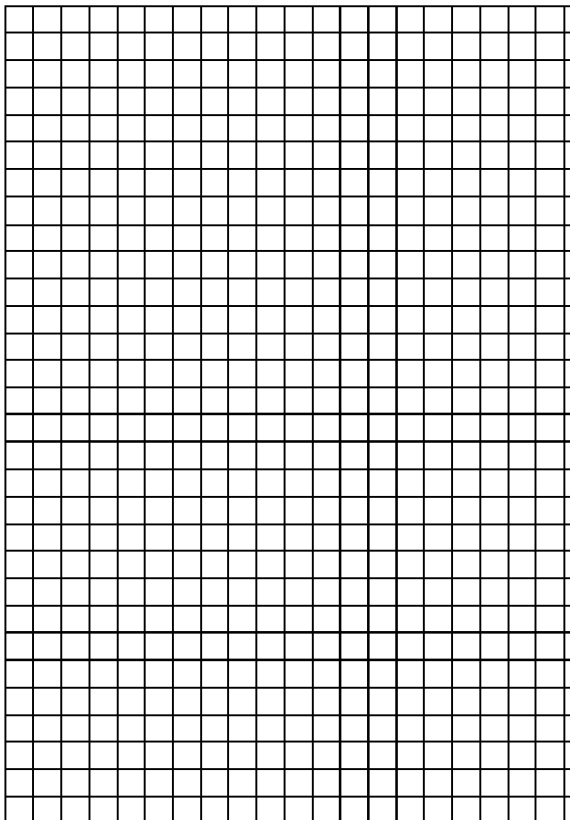

4. Use this test pattern to confirm the torque limiter for Ink film and platen roller timing.

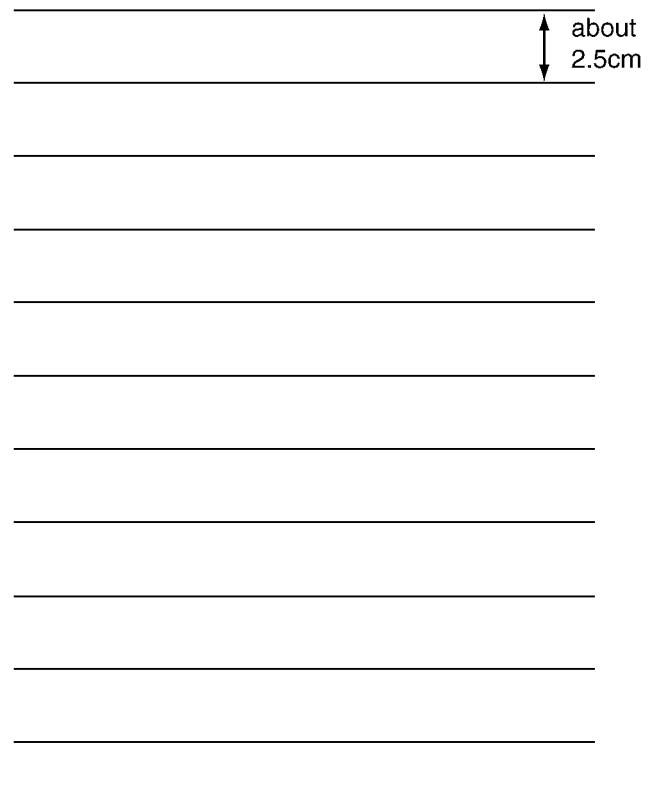

11 Service Mode

The programming functions are used to program the various features and functions of the machine, and to test the machine. This facilitates communication between the user and the service man while programming the unit.

11.1. Programming and Lists

11.1.1. Operation

There are 2 basic categories of programming functions, the User Mode and the Service Mode. The Service Mode is further broken down into the normal and special programs. The normal programs are those listed in the Operating Instructions and are available to the user. The special programs are only those listed here and not displayed to the user. In both the User and Service Modes, there are Set Functions and Test Functions. The Set Functions are used to program various features and functions, and the Test Functions are used to test the various functions. The Set Functions are accessed by entering their code, changing the appropriate value, then pressing the SET key. The Test Functions are accessed by entering their code and pressing the key listed on the menu. While programming, to cancel any entry, press the STOP key.

11.1.2. Operation Flow

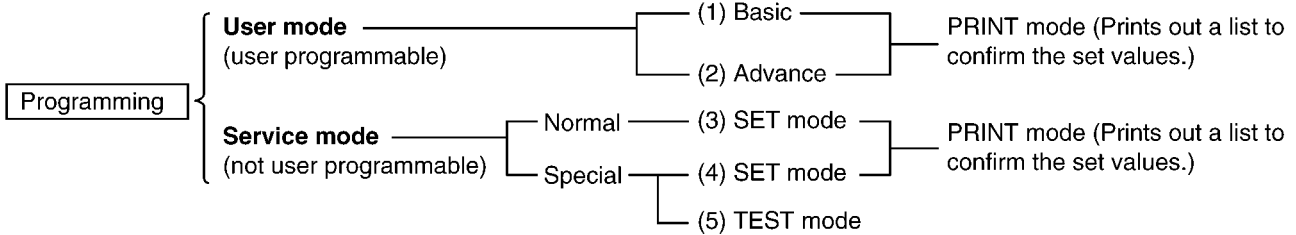

■ Operating Procedure

[MENU]

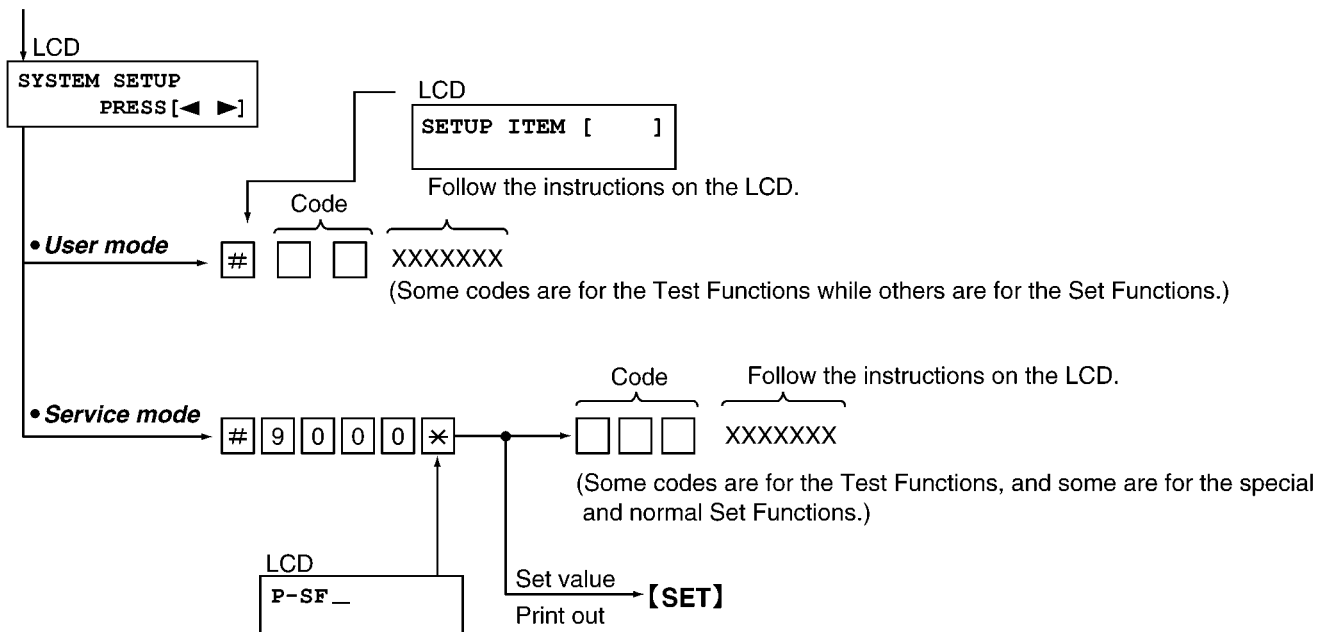

• User mode Print out

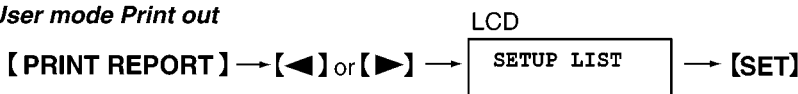

11.1.3. Service Function Table

Code	Function	Set Value	Effective Range	Default	Remarks
501	Pause time set	X 100 msec	001~600	30	-----
503	Dial speed select	1: 10 pps 2: 20 pps	1, 2	1	-----
510	VOX time (KX-FP218)	1:8sec 2:6sec 3:4sec	1~3	2	-----
511	VOX sense (KX-FP218)	1:High 2:Low	1, 2	1	When the TAM (or EXT TAM) does not stop recording the ICM because noise is detected on the telephone line, change this setting to "LOW".
514	Bell detection time	X 100 msec	1~9	6	-----
520	CED frequency select	1:2100 Hz 2:1100 Hz	1, 2	1	See Symptom/Countermeasure Table for long distance and international calls in The unit can copy, but cannot either transmit/receive long distance or international communications (P.93) .
521	International mode select	1:ON 2:OFF	1, 2	1	See Symptom/Countermeasure Table for long distance and international calls in The unit can copy, but cannot either transmit/receive long distance or international communications (P.93) .
522	Auto standby select	1:ON 2:OFF	1, 2	1	The resolution reverts to the default when transmission is complete.
523	Receive equalizer select	1: 0 km 2: 1.8 km 3: 3.6 km 4: 7.2 km	1~4	1	When the telephone station is far from the unit or reception cannot be performed correctly, adjust accordingly.
524	Transmission equalizer select	1: 0 km 2: 1.8 km 3: 3.6 km 4: 7.2 km	1~4	1	When the telephone station is far from the unit or transmission cannot be performed correctly, adjust accordingly.
544	Document feed position adjustment value set	1~9 mm	1~9	5	When the ADF function is in correct, adjust the feed position.
550	Memory clear				See Memory Clear Specification (P.66) .
551	ROM check				See Test Mode (P.58) .
552	DTMF single tone test	1:ON 2:OFF	1, 2	2	See Test Mode (P.58) .
553	Monitor on FAX communication select	1:OFF 2:PHASE B 3:ALL	1~3	1	Sets whether to monitor the line signal with the unit's speaker during FAX communication or not.
554	Modem test				See Test Mode (P.58) .
555	Scan check				See Test Mode (P.58) .
556	Motor test				See Test Mode (P.58) .
557	LED test				See Test Mode (P.58) .
558	LCD test				See Test Mode (P.58) .
559	Document jam detection select	1:ON 2:OFF	1, 2	1	Sets whether or not to detect a paper jam. If a document with a length longer than 600 mm is copied or transmitted, the unit stops copying or transmitting as a paper jamming because a document over 600 mm is not normal. In the factory, transmitting or copying a document longer than 600 mm is done as an aging test. In this case, OFF is selected.
561	KEY test				See Test Mode (P.58) .
567	T0 timer	X second	001~255	046	Sets a higher value when the response from the other party needs more time during automatic FAX transmission.
570	BREAK % select	1:61% 2:67%	1, 2	1	Sets the % break of pulse dialling according PBX.
571	ITS auto redial time set	X number of times	00~99	11	Selects the number of times that ITS is redialled (not including the first dial).
572	ITS auto redial line disconnection time set	X second	001~999	040	Sets the interval of ITS redialling.
573	Remote turn-on ring number set (KX-FP207)	X number of rings	00~99	10	Sets the number of rings before the unit starts to receive a document in the TEL mode.
573	Remote turn-on ring number set (KX-FP218)	X number of rings	00~99	10	Sets the number of rings before the unit starts to receive a document in the TEL mode.
574	Dial tone detect check	1:ON 2:OFF	1, 2	2	-----

Code	Function	Set Value	Effective Range	Default	Remarks
580	TAM continuous tone detection (KX-FP218)	1:ON 2:OFF	1, 2	1	ON : Stops TAM operation when Dial tone, etc. are detected.
590	FAX auto redial time set	X number of times	00~99	05	Selects the number of redial times during FAX communication (not including the first dial).
591	FAX auto redial time disconnection time set	X second	001~999	065	Sets the FAX redial interval during FAX communication.
592	CNG transmit select	1:OFF 2:ALL 3:AUTO	1~3	2	Lets you select the CNG output during FAX transmission. ALL: CNG is output at phase A. AUTO: CNG id output only when automatic dialling is performed. OFF: CNG id not output at phase A. Refer to Sometime there is a transmit problem (P.90).
593	Time between CED and 300bps	1:75 msec 2:500 msec 3:1 sec	1~3	1	See Symptom/Countermeasure Table for long distance and international calls in The unit can copy, but cannot either transmit/receive long distance or international communications (P.93). Refer to Receive Problem (P.91) .
594	Overseas DIS detection select	1:detects at the 1st time 2:detects at the 2st time	1, 2	1	See Symptom/Countermeasure Table for long distance and international calls in The unit can copy, but cannot either transmit/receive long distance or international communications (P.93). Refer to Sometime there is a transmit problem (P.90).
595	Receive error limit value set	1:5 % 2:10 % 3:15 % 4:20%	1~4	2	Refer to Receive Problem (P.91).
596	Transmit level set	X dbm (10 = -10 dbm)	- 15~00	10	Selects the FAX transmission level. Refer to Sometime there is a transmit problem (P.90) and Receive Problem (P.91).
598	Receiving sensitivity	X dbm (40 = -40 dbm)	-20~-48	42	Used when there is an error problem. Refer to The unit can copy, but cannot either transmit/receive long distance or international communications (P.93). Power is OFF/ON after changing this set value.
599	ECM frame size	1:256 2:64	1, 2	1	-----
710	Memory clear except History data				Refer to Memory Clear Specification (P.66).
717	Transmit speed selection (KX-FP207)	1:9600BPS 2:7200BPS 3:4800BPS 4:2400BPS	1~4	1	Adjusts the speed to start training during FAX transmission. Refer to Sometime there is a transmit problem (P.90) and The unit can copy, but the transmission and reception image are incorrect (P.95).
717	Transmit speed selection (KX-FP218)	1:14400BPS 2:12000BPS 3:9600BPS 4:7200BPS 5:4800BPS 6:2400BPS	1~6	1	Adjusts the speed to start training during FAX transmission. Refer to Sometime there is a transmit problem (P.90) and The unit can copy, but the transmission and reception image are incorrect (P.95).
718	Receive speed selection (KX-FP207)	1:9600BPS 2:7200BPS 3:4800BPS 4:2400BPS	1~4	1	Adjusts the speed to start training during FAX reception. Refer to Receive Problem (P.91) and The unit can copy, but the transmission and reception image are incorrect (P.95).
718	Receive speed selection (KX-FP218)	1:14400BPS 2:12000BPS 3:9600BPS 4:7200BPS 5:4800BPS 6:2400BPS	1~6	1	Adjusts the speed to start training during FAX reception. Refer to Receive Problem (P.91) and The unit can copy, but the transmission and reception image are incorrect (P.95).
722	Redial tone detect	1:ON 2:OFF	1, 2	1	Sets the tone detection mode after redialling.
745	Power ON film feed	1:ON 2:OFF	1, 2	1	When the power is turned on, the film is wound to take up any slack.
763	CNG detect time for friendly reception	1:10 sec 2:20 sec 3:30 sec	1~3	3	Selects the CNG detection tone of friendly reception.
773	DIS-DIC interval	1: 500msec 2: 200msec	1, 2	2	This is similar to #594. The time interval from receiving DIS to sending DCS can be changed to wait for the echo canceler to recover.
774	T4 timer	X 100 msec	00~99	0	Use this function when delay occurs in the line and communication (ex. Mobile comm) does not work well.
784	Voice prompt test (KX-FP218)				See Test Mode (P.58).
815	Sensor & Vox check				See Test Mode (P.58).

Code	Function	Set Value	Effective Range	Default	Remarks
841	Digital SP-phone check (KX-FP218)				See Digital Speakerphone (KX-FP218) (P.126).
852	Print test pattern				See Test Mode (P.58).
853	Top margin		1~9	5	-----
861	Paper size	1:A4 2:LETTER	1, 2	1	-----
874	DTMF ON time	X 10 msec	06~20	10	-----
875	DTMF OFF time	X 10 msec	06~20	10	-----
880	History list				See History (P.70).
881	Journal 2 list				See Printout Example (P.86).
882	Journal 3 list				See Printout Example (P.86).
961	The time transmitting the false ring back tone	X sec	01~10	07	Set the time transmitting the false ring back tone to the line in TEL/FAX mode.
962	The operator calling time	X sec	05~30	10	Set the operator calling time through the speaker in TEL/Fax mode.

11.1.4. Memory Clear Specification

Item	Status after Memory Clear	
	Service Mode #550 ^{*1}	Service Mode #710 ^{*2}
Date and time (user mode #001)	—	Default
Your logo (user mode #002)	—	Default
Your Fax Number (user mode #003)	—	Default
One touch dial and Phonebook	—	Default
History	—	—
Top margin (service mode #853)	—	—
Other Setting data (User setting and Service setting data)	Default	Default

— : Not changed

*1 Execute Service Mode #550 when you want to reset the all setting data keeping the user information.

*2 Execute Service Mode #710 to clear the user information in case that Main Unit is recycled.

Note:

- Please restart a power supply after clearing a memory.

11.2. The Example of the Printed List

11.2.1. User Mode

11.2.1.1. KX-FP207FX-S

SETUP LIST

[BASIC FEATURE LIST]

NO.	FEATURE	CURRENT SETTING
Code → #01	SET DATE & TIME	1 Jan. 2006 1:22
#02	YOUR LOGO	
#03	YOUR FAX NUMBER	
#04	PRINT SENDING REPORT	ERROR [ERROR, ON, OFF]
#06	FAX RING COUNT	2 [1...9]
#13	DIAL MODE	TONE [TONE, PULSE]
#17	RINGER TONE	TONE 1 [TONE 1...3]

Set Value

[ADVANCED FEATURE LIST]

NO.	FEATURE	CURRENT SETTING
Code → #22	JOURNAL AUTO PRINT	ON [ON, OFF]
#23	OVERSEAS MODE	ERROR [NEXT FAX, ERROR, OFF]
#25	DELAYED TRANSMISSION	OFF [ON, OFF]
	DESTINATION =	
	START TIME = 0:00	
#26	AUTO CALLER ID LIST	OFF [ON, OFF]
#34	QUICK SCAN	OFF [ON, OFF]
#36	RCV REDUCTION	92% [72, 86, 92, 100]
#39	LCD CONTRAST	NORMAL [NORMAL, DARKER]
#41	FAX ACTIVATION CODE	ON [ON, OFF]
	CODE = *#9	
#44	MEMORY RECEIVE ALERT	ON [ON, OFF]
#46	FRIENDLY RECEPTION	ON [ON, OFF]
#49	AUTO DISCONNECT	ON [ON, OFF]
	CODE = *0	
#58	SCAN CONTRAST	NORMAL [NORMAL, LIGHT, DARKER]
#68	EOM SELECTION	ON [ON, OFF]
NOTE : You cannot change the setting of this feature, if there are stored documents in memory.		
#72	SET RECALL TIME	600ms [80, 90, 100, 110, 160, 200, 250, 300, 400, 600, 700, 900]
#73	MANUAL ANSWER MODE	TEL [TEL, TEL/FAX]
#76	CONNECTING TONE	ON [ON, OFF]
#78	TEL/FAX DELAYED RING	2 [1...9]
#80	SET DEFAULT (EXCEPT #58)	

Set Value

11.2.1.2. KX-FP218FX-S

SETUP LIST

[BASIC FEATURE LIST]

NO.	FEATURE	CURRENT SETTING
Code → #01	SET DATE & TIME	1 Jan. 2005 0:14
#02	YOUR LOGO	
#03	YOUR FAX NUMBER	
#04	PRINT SENDING REPORT	ERROR [ERROR, ON, OFF]
#06	TAM/FAX RING COUNT	2 [2...7, TOLL SAVER]
#10	RECORDING TIME	3 MINUTES [1...3 MIN, GREETING ONLY]
#11	REMOTE TAM ID	
#13	DIAL MODE	TONE [TONE, PULSE]
#17	RINGER TONE	TONE 1 [TONE 1...3]

Set Value

[ADVANCED FEATURE LIST]

NO.	FEATURE	CURRENT SETTING
Code → #22	JOURNAL AUTO PRINT	ON [ON, OFF]
#23	OVERSEAS MODE	ERROR [NEXT FAX, ERROR, OFF]
#25	DELAYED TRANSMISSION	OFF [ON, OFF]
	DESTINATION =	
	START TIME = 0:00	
#26	AUTO CALLER ID LIST	OFF [ON, OFF]
#34	QUICK SCAN	OFF [ON, OFF]
#36	RCV REDUCTION	92% [72, 86, 92, 100]
#39	LCD CONTRAST	NORMAL [NORMAL, DARKER]
#41	FAX ACTIVATION CODE	ON [ON, OFF]
	CODE = *#9	
#44	MEMORY RECEIVE ALERT	ON [ON, OFF]
#46	FRIENDLY RECEPTION	ON [ON, OFF]
#47	VOICE GUIDANCE	ON [ON, OFF]
#49	AUTO DISCONNECT	ON [ON, OFF]
	CODE = *0	
#54	GREETING MSG. RECORDING TIME	16s [16s, 60s]
NOTE : If you change from 60sec. to 16sec., your-greeting will be erased and your new greeting will be limited to 16 seconds.		
#58	SCAN CONTRAST	NORMAL [NORMAL, LIGHT, DARKER]
#67	ICM MONITOR	ON [ON, OFF]
#68	ECM SELECTION	ON [ON, OFF]
NOTE : You cannot change the setting of this feature, if there are stored documents in memory.		
#72	SET RECALL TIME	600ms [80, 90, 100, 110, 160, 200, 250, 300, 400, 600, 700, 900]
#73	MANUAL ANSWER MODE	TEL [TEL, TEL/FAX]
#76	CONNECTING TONE	ON [ON, OFF]
#77	AUTO ANSWER MODE	TAM/FAX [TAM/FAX, FAX ONLY]
#78	TEL/FAX DELAYED RING	2 [1...9]
#80	SET DEFAULT (EXCEPT #68)	

Set Value

Note:

The above values are the default values.

11.2.2. Service Mode Settings

11.2.2.1. KX-FP207FX-S

【 SERVICE DATA LIST 】

Code	501 PAUSE TIME	=	030*100ms	[001...600]*100ms
	503 DIAL SPEED	=	10pps	[1=10 2=20]pps
	520 CED FREQ.	=	2100Hz	[1=2100 2=1100]Hz
	521 INTL. MODE	=	ON	[1=ON 2=OFF]
	522 AUTO STANDBY	=	ON	[1=ON 2=OFF]
	523 RX EQL.	=	0.0Km	[1=0.0 2=1.8 3=3.6 4=7.2]Km
	524 TX EQL.	=	0.0Km	[1=0.0 2=1.8 3=3.6 4=7.2]Km
	853 TOP MARGIN	=	5	[1...9]

【 SPECIAL SERVICE SETTINGS 】

Code	514	544	552	553	559	567	570	571	572	573	590	591	592
	6	5	2	1	1	046	1	11	040	10	05	065	2
	593	594	595	596	598	599	717	718	722	745	763	773	774
	1	1	2	10	42	1	1	1	1	1	3	2	00
	861	874	875	961	962								
	1	10	10	07	10								

USAGE TIME = 00001 HOURS

Version = G951FN BCF9

11.2.2.2. KX-FP218FX-S

【 SERVICE DATA LIST 】

Code	501 PAUSE TIME	=	030*100ms	[001...600]*100ms
	503 DIAL SPEED	=	10pps	[1=10 2=20]pps
	510 VOX TIME	=	6sec	[1=8 2=5 3=4]sec
	520 CED FREQ.	=	2100Hz	[1=2100 2=1100]Hz
	521 INTL. MODE	=	ON	[1=ON 2=OFF]
	522 AUTO STANDBY	=	ON	[1=ON 2=OFF]
	523 RX EQL.	=	0.0Km	[1=0.0 2=1.8 3=3.6 4=7.2]Km
	524 TX EQL.	=	0.0Km	[1=0.0 2=1.8 3=3.6 4=7.2]Km
	853 TOP MARGIN	=	5	[1...9]

【 SPECIAL SERVICE SETTINGS 】

Code	511	514	544	552	553	559	567	570	571	572	573	590	590
	1	6	5	2	1	1	046	1	11	040	10	1	05
	591	592	593	594	595	596	598	599	717	718	722	745	763
	065	2	1	1	2	10	42	1	1	1	1	1	3
	773	774	861	874	875	961	962						
	2	00	1	10	10	07	10						

USAGE TIME = 00000 HOURS

Version = G961FN BDD1

Note:

The above values are the default values.

11.2.3. History

[HISTORY]

```

[ V e r 1 . 5 ] — (1)   [ 9 2 E 4 ] — (2)
[ N O N E ] — (3)
[ N O N E ] — (4)
[ N O N E ] — (5)

(6) — [ 0 0 0 0 0 ] [ 0 1 ] — (7) [ 0 1 ] — (8) [ 2 0 0 6 ] — (9) [ 0 0 0 0 ] — (10)
(11) — [ 0 0 0 0 0 ] [ 0 0 0 0 0 ] — (12)
(13) — [ 0 0 0 0 0 ] [ 0 0 0 0 0 ] [ N O N E ] [ 0 0 0 0 0 ] — (16) [ T A M / F A X ] — (17)
Factory use only — [ 0 0 0 0 0 ] [ 0 0 0 0 0 ] [ J O N E ] — (18) [ 9 2 % ] — (19) [ 0 0 0 0 1 ] — (20)
(21) — [ 0 0 0 0 0 ] [ 0 0 0 0 0 ] [ 0 0 0 0 0 ] [ 0 0 0 0 0 ] — (24) [ 0 0 0 0 0 ] — (25)
(26) — [ N O N E ] [ N O N E ] — (27) [ N O N E ] — (28) [ N O N E ] — (29)
(30) — [ 0 0 0 ] (31) — [ 0 0 0 ] (32) — [ 0 0 0 0 0 ] [ N O N E ] — (33)
(34) — [ 0 0 0 0 0 ] [ 0 0 0 0 0 ] — (35) [ 0 0 0 0 0 ] — (36) [ 0 0 0 0 0 0 ] — (37)
(40) — [ 0 0 0 0 0 ] [ 0 0 0 0 0 ] [ 0 0 0 0 0 ] [ 0 0 0 0 0 ] — (43) [ 0 0 0 0 0 ] — (44)

```

NAME _____ DATE _____ DEALER _____ FILM _____

CUSTOMER COMPLAINT

SURVEY RESULT : OKOK (UNKNOWN/DESIGN/EDUC) DEFECT (PART/WORKER/DESIGN)
 ABUSE (CUST/DEALER/SHIP) NEW (OPEN/NOT)
 PHONE SURVEY RESULT.

Note:
 See the following descriptions of this report. Item No. (1) ~ (44) are corresponding to the listed items in **Descriptions of the History Report** (P.71).

11.2.3.1. Descriptions of the History Report

- | | |
|---|--|
| <p>(1) SOFTWARE VERSION
FLASH ROM version</p> <p>(2) SUM
FLASH ROM internal data calculation.</p> <p>(3) YOUR LOGO
The user logo recorded in the unit. If it is not recorded, NONE will be displayed.</p> <p>(4) YOUR TELEPHONE NUMBER
The user telephone number recorded in the unit. If it is not recorded, NONE will be displayed.</p> <p>(5) FAX PAGER NUMBER
If you program a pager number into the unit, the pager number will be displayed here.</p> <p>(6) FACTORY - CUSTOMER
This shows how many days from factory production until the user turns ON the unit.</p> <p>(7) MONTH
The shows the very first month, date, year and time set by the user after they purchased the unit.</p> <p>(8) DAY
The shows the very first month, date, year and time set by the user after they purchased the unit.</p> <p>(9) YEAR
The shows the very first month, date, year and time set by the user after they purchased the unit.</p> <p>(10) TIME
The shows the very first month, date, year and time set by the user after they purchased the unit.</p> <p>(11) USAGE TIME
The amount of time the unit has been powered ON.</p> <p>(12) FACTORY - NOW
This shows how many days from factory production until the user prints out this history list.</p> <p>(13) TEL MODE
The amount of time the TEL mode setting was used.</p> <p>(14) FAX MODE
The amount of time the FAX mode setting was used.</p> <p>(15) TEL/FAX MODE
The amount of time the TEL/FAX mode setting was used.</p> <p>(16) ANS/FAX MODE
The amount of time the ANS/FAX mode setting was used.</p> <p>(17) FINAL RECEIVE MODE
The last set receiving mode by the user.</p> <p>(18) TONE/PULSE SELECTION
The most recently used setting used, either TONE or PULSE.</p> <p>(19) RECEIVE REDUCTION
The compression rate when receiving.</p> <p>(20) SETTING NO. OF DIRECTORY
The recorded directory stations.</p> <p>(21) NUMBER OF COPY
The number of pages copied.</p> | <p>(22) NUMBER OF RECEIVE
The number of pages received.</p> <p>(23) NUMBER OF SENDING
The number of pages sent.</p> <p>(24) NUMBER OF CALLER ID
The number of times Caller ID was received.</p> <p>(25) NUMBER OF RECORDING MESSAGE
The number of messages recorded in TAM.</p> <p>(26)~(29) Not Used</p> <p>(30) NUMBER OF PRINTING WARNING LIST
The number of warning lists printed until now.</p> <p>(31) NUMBER OF PRINTING HELP
The number of help lists printed until now.</p> <p>(32) NUMBER OF DIVIDED PRINTING IN FAX RECEPTION
The number of faxes received that were divided into more than one sheet since the unit was purchased.</p> <p>(33) Not used</p> <p>(34) FAX MODE
Means the unit received a fax message in the FAX mode.</p> <p>(35) MAN RCV
Means the unit received a fax message by manual operation.</p> <p>(36) FRN RCV
Means the unit received a fax message by friendly signal detection.</p> <p>(37) VOX
Means the unit detected silence or no voice.</p> <p>(38) RMT DTMF
Means the unit detected DTMF (Remote Fax activation code) entered remotely.</p> <p>(39) PAL DTMF
Means the unit detected DTMF (Remote Fax activation code) entered by a parallel connected telephone.</p> <p>(40) TURN-ON
Means the unit started to receive after 10 rings. (Remote Turn On: Service Code #573)</p> <p>(41) TIME OUT
Means the unit started to receive after Ring Time Out in the EXT-TAM or TEL/FAX mode.</p> <p>(42) IDENT
Means the unit detected Ring Detection.</p> <p>(43) CNG OGM
Means the unit detected the CNG while it was sending the Dummy Ring Back Tone in the TEL/FAX mode, or while answering a call in the EXT-TAM mode. Or means the unit detected the CNG while it was sending the OGM in the ANS/FAX mode.</p> <p>(44) CNG ICM
Means the unit detected the CNG while it was recording the ICM in the ANS/FAX mode.</p> |
|---|--|

12 Troubleshooting Guide

12.1. Troubleshooting Summary

After confirming the problem by asking the user, troubleshoot according to the instructions and observe the following precautions.

12.1.1. Precautions

1. If there is a problem with the print quality or the paper feed, first check if the installation space and the print paper meets the specifications, the paper selection lever/paper thickness lever is set correctly, and the paper is set correctly without any slack.
2. Before troubleshooting, first check that the connectors and cables are connected correctly (not loose).
If the problem occurs randomly, check it very carefully.
3. When connecting the AC power cord with the unit and checking the operation, exercise utmost care when handling electric parts in order to avoid electric shocks and short-circuits.
4. After troubleshooting, double check that you have not forgotten any connectors, left any loose screws, etc.
5. Always test to verify that the unit is working normally.

12.2. Error Messages-Display

If the unit detects a problem, one or more of the following messages will appear on the display.

The explanations given in the [] are for servicemen only.

“BACK COVER OPEN”

- The back cover is open. Close the back cover firmly.

“CALL SERVICE”

- [This error is displayed when the thermal head does not warm up. Check the thermistor on the thermal head and connector lead.]

“CALL SERVICE 2”

- [This error is displayed when the gear is not in an idle state. Check the GEAR BLOCK.]
(Refer to **Gear Section** (P.165).)

“CHECK DOCUMENT”

- The document was not fed into the unit properly. Re-insert the document. If misfeeding occurs frequently, clean the document feeder rollers and try again.
(Refer to **Document feeder/recording paper feeder/scanner glass cleaning** (P.174).)
- The document is longer than 600 mm. Press **[STOP]** to remove the document. Divide the document into two or more sheets, and try again.
[Alternately, turn off service code #559 to enable sending of documents longer than 600 mm.]
(Refer to **Service Function Table** (P.63).)

“CHECK FILM”

- The ink film is empty. Replace the ink film with a new one.
- The ink film is not installed. Install it.
- The ink film is slack or creased. Tighten it.
(Refer to step 5 on **Installing the Ink Film** (P.53).)

“CHECK MEMORY”

- The memory (telephone numbers, parameters, etc.) has been erased. Re-program.

“CHECK PAPER”

- The recording paper is not installed or the unit has run out of paper. Install paper and **[SET]** to clear the message.
- The recording paper was not fed into the unit properly. (Refer to **When the recording paper was not fed into the unit properly** (P.173).) Re-install paper and press **[SET]** to clear the message.
(Refer to **Installing the Recording Paper** (P.55).)
- The recording paper has jammed near the recording paper entrance. Remove the jammed paper and press **[SET]** to clear the message.
(Refer to **Recording Paper Jams** (P.172).)

“FAX IN MEMORY”

- See the other displayed message instructions to print out the document.
Received documents are stored in memory due to a lack of recording paper, a lack of ink film or a recording paper jam. Install paper, install ink film or remove the jammed paper. You will lose all faxes in memory if the power is removed. Check with power connected.
(Refer to **Installing the Recording Paper** (P.55) and **Installing the Ink Film** (P.53) and **Recording Paper Jams** (P.172).)

“FAX MEMORY FULL”

- The memory is full of received documents due to a lack of recording paper, a lack of ink film or a recording paper jam. Install paper, install ink film or remove the jammed paper. You will lose all faxes in memory if the power is removed. Check with power connected. (Refer to **Installing the Recording Paper** (P.55) and **Installing the Ink Film** (P.53) and **Recording Paper Jams** (P.172).)
- When performing memory transmission, the document being stored exceeded the memory capacity of the unit. Send the entire document manually.

“FILM EMPTY”

- The ink film is empty. Replace the ink film with a new one.
- The ink film is slack. Tighten it (See step 5 on **Installing the Ink Film** (P.53).) and install again.
- The fax machine is positioned near appliances such as TVs or speakers which generate an intense magnetic field.

“FILM NEAR EMPTY”

- The remaining ink film is low. Prepare a new ink film.
(Refer to **Optional Accessories** (P.9).)

“MEMORY FULL”

- When making a copy, the document being stored exceeded the memory capacity of the unit. Press **[STOP]** to clear the message. Divide the document into sections.

“MESSAGE FULL”

- There is no room left in memory to record voice messages. Erase unnecessary messages.

“MODEM ERROR”

- There is something wrong with the unit's modem. (Refer to **Test Mode** (P.58) and **Digital Board Section** (P.116).)

“NO TAM GREETING”

- Your TAM/FAX greeting message is not recorded. Record a message.
- The voice guidance feature is set to off. Activate feature #47 on P.98. Prerecorded greeting message will be adopted.

“NO FAX REPLY”

- The other party's fax machine is busy or has run out of recording paper. Try again.

**“OPEN CABINET
CHECK FILM SLACK”
“OPEN CABINET
CHECK FILM TYPE”**

- Please use genuine Panasonic replacement film. (Refer to **Optional Accessories** (P.9).)
- The ink film is slack. Tighten it (See step 5 on **Installing the Ink Film** (P.53)).
- The fax machine is positioned near appliances such as TVs or speakers which generate an intense magnetic field.

“PAPER JAMMED”

- A recording paper jam occurred. Remove the jammed paper. (Refer to **Recording Paper Jams** (P.172).)
- You forced the recording paper into the paper tray too strongly. Remove all of the installed paper, and re-install it gently.

“PHONEBOOK FULL”

- There is no space to store new items in the phonebook. Erase unnecessary items.

“PLEASE WAIT”

- The unit is checking that there is no slack or crease in the ink film. Wait for a moment while the check is completed.

“POLLING ERROR”

- The other party's fax machine does not offer the polling function. Check with the other party.

“RECORDING ERROR”

- The greeting message or memo message you recorded was under 1 second long. Record a longer message.

“REDIAL TIME OUT”

- The other party's fax machine is busy or has run out of recording paper. Try again.

“REMOVE DOCUMENT”

- The document is jammed. Remove the jammed document. (Refer to **Document Jams - sending** (P.173).)
- Press **[STOP]** to eject the jammed paper.

“TRANSMIT ERROR”

- A transmission error occurred. Try again.
- If you send a fax overseas, try the following:
 - Use the overseas transmission mode (feature #23 on **Program Mode Table** (P.98)).
 - Add 2 pauses at the end of the telephone number or dial manually.

“UNIT OVERHEATED”

- The unit is too hot. Stop using the unit for a while and let the unit cool down.

12.3. Error Messages-Report

If a problem occurs during fax transmission or reception, one of the following messages will be printed on the sending and journal reports.

12.3.1. Journal Report

1. Press [PRINT REPORT] repeatedly to display "PRINT REPORT".
2. Press [◀] or [▶] until the "JOURNAL REPORT" is displayed.
3. Press [SET].
4. The report is printed out.

JOURNAL							
						20 Jan. 2006 01:19PM	
						YOUR LOGO :	
						YOUR FAX NO:	
NO.	OTHER FACSIMILE	START TIME	USAGE TIME	MODE	PAGES	RESULT	*CODE
01	2345678	20 Jan. 01:18PM	00'51	SND	00	COMMUNICATION ERROR	(43)

(3)
SND: Sent directly. (2) Communication message
RCV: Received directly

Error code table:

(1) CODE	(2) RESULT	(3) MODE	SYMPTOM	Counter-measure*
	PRESSED THE STOP KEY	SND & RCV	Communication was interrupted by the STOP button.	
	DOCUMENT JAMMED	SND	The document paper is jammed.	
	NO DOCUMENT	SND	No document paper.	
	THE COVER WAS OPENED	SND & RCV	The cover is open.	
	OTHER FAX NOT RESPONDING	SND	Transmission is finished when the T1 TIMER expires.	1
28	COMMUNICATION ERROR	SND & RCV		
41	COMMUNICATION ERROR	SND	DCN is received after DCS transmission.	2
42	COMMUNICATION ERROR	SND	FTT is received after transmission of a 2400BPS training signal.	3
43	COMMUNICATION ERROR	SND	No response after post message is transmitted three times.	4
44	COMMUNICATION ERROR	SND	RTN and PIN are received.	5
46	COMMUNICATION ERROR	RCV	No response after FTT is transmitted.	6
48	COMMUNICATION ERROR	RCV	No post message.	7
49	COMMUNICATION ERROR	RCV	RTN is transmitted.	8
50	COMMUNICATION ERROR	RCV	PIN is transmitted (to PRI-Q).	8
51	COMMUNICATION ERROR	RCV	PIN is transmitted.	8
	OTHER FAX NOT RESPONDING	RCV	Reception is finished when the T1 TIMER expires.	9
54	ERROR-NOT YOUR UNIT	RCV	DCN is received after DIS transmission.	11
58	COMMUNICATION ERROR	RCV	DCN is received after FTT transmission.	13
59	ERROR-NOT YOUR UNIT	SND	DCN responds to the post message.	14
65	COMMUNICATION ERROR	SND	DCN is received before DIS reception.	2
65	COMMUNICATION ERROR	RCV	Reception is not EOP, EOM PIP, PIN, RTP or RTN.	2
68	COMMUNICATION ERROR	RCV	No response at the other party after MCF or CFR is transmitted.	13
70	ERROR-NOT YOUR UNIT	RCV	DCN is received after CFR transmission.	13
72	COMMUNICATION ERROR	RCV	Carrier is cut when the image signal is received.	16
	MEMORY FULL	RCV	The document was not received due to memory full.	
	JUNK FAX PROH. REJECT	RCV	The fax was rejected by the junk fax prohibitor feature.	
	CANCELED	SND	The multi-station transmission was rejected by the user.	
FF	COMMUNICATION ERROR	SND & RCV	Modem error. For the DCN, DCN, etc. abbreviations, refer to Modem Section (P.33).	12

SND=TRANSMISSION RCV=RECEPTION

Most fax communication problems can be resolved by the following steps.

1. Change the transmit level. (Service code: 596, refer to **Service Function Table** (P.63).)
2. Change the TX speed/RX speed. (Service code: 717/718, refer to **Service Function Table** (P.63).)

Note*:

If the problem remains, see the following "Countermeasure" flow chart.

Countermeasure

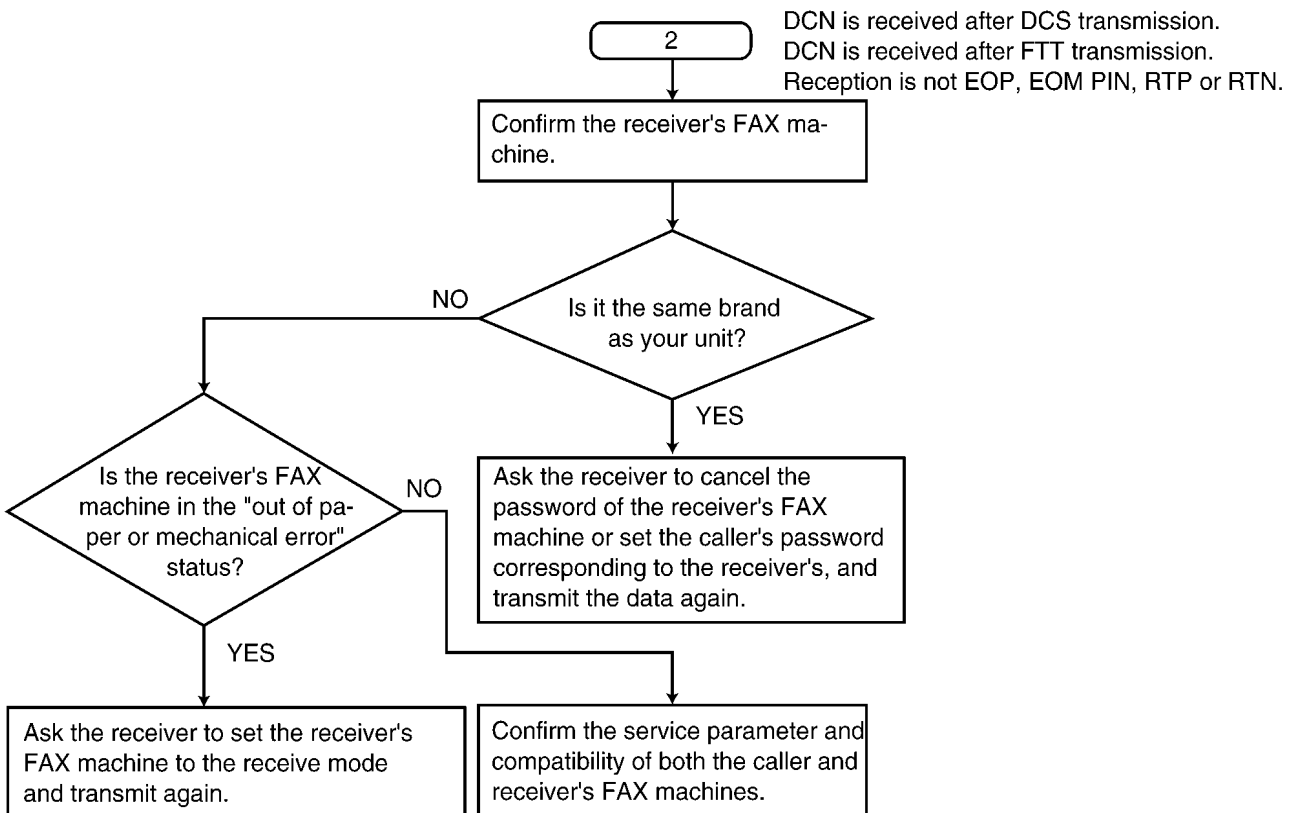
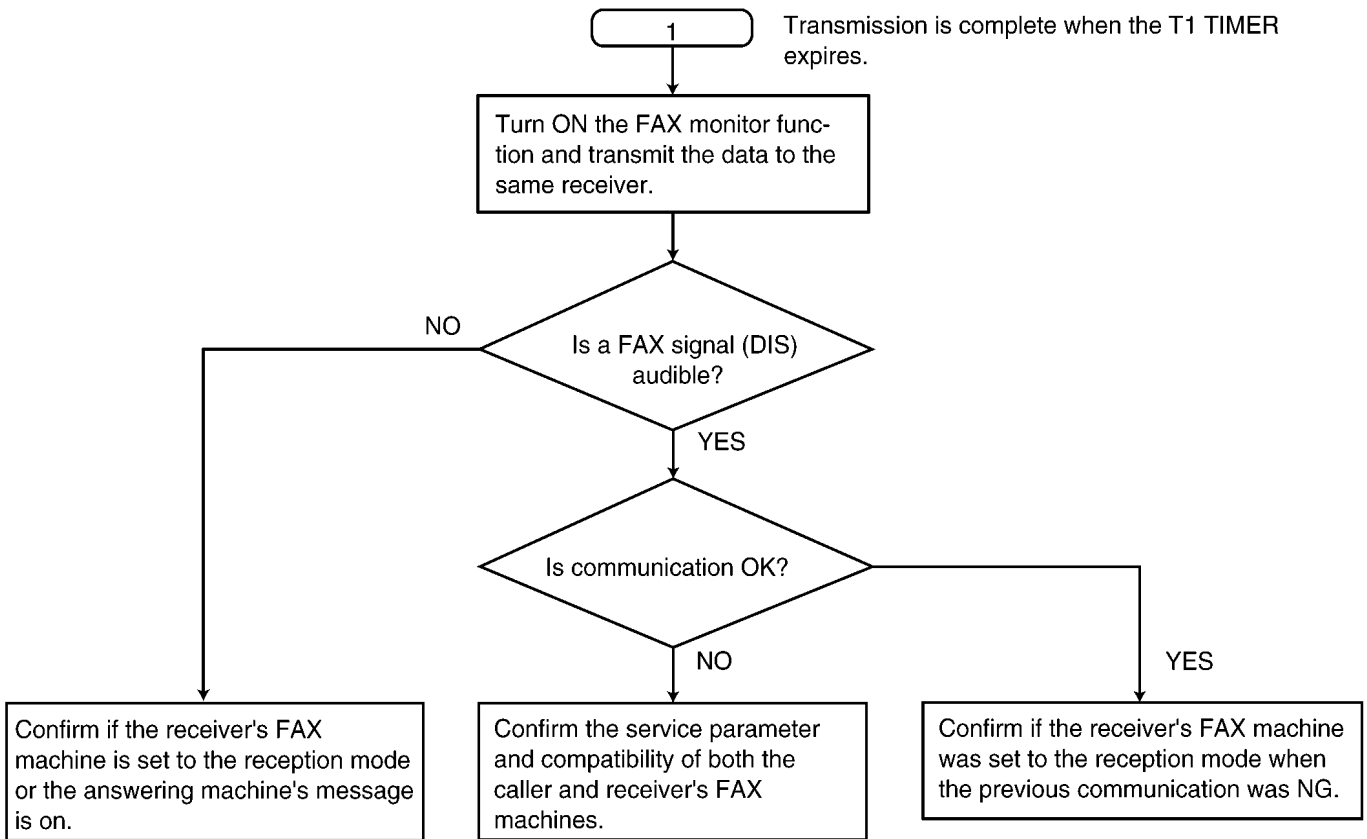

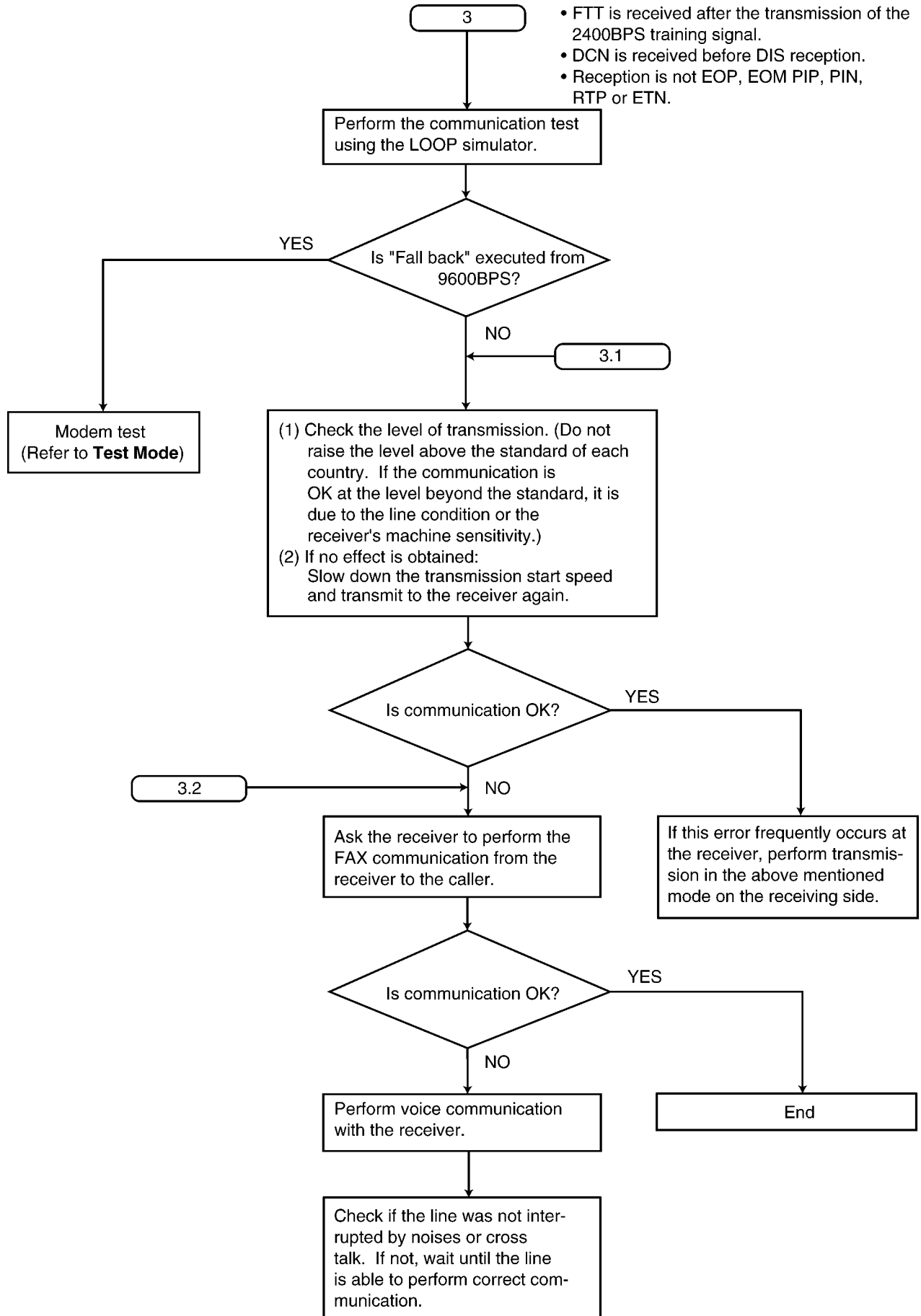

REFERENCE:
Test Mode (P.58)

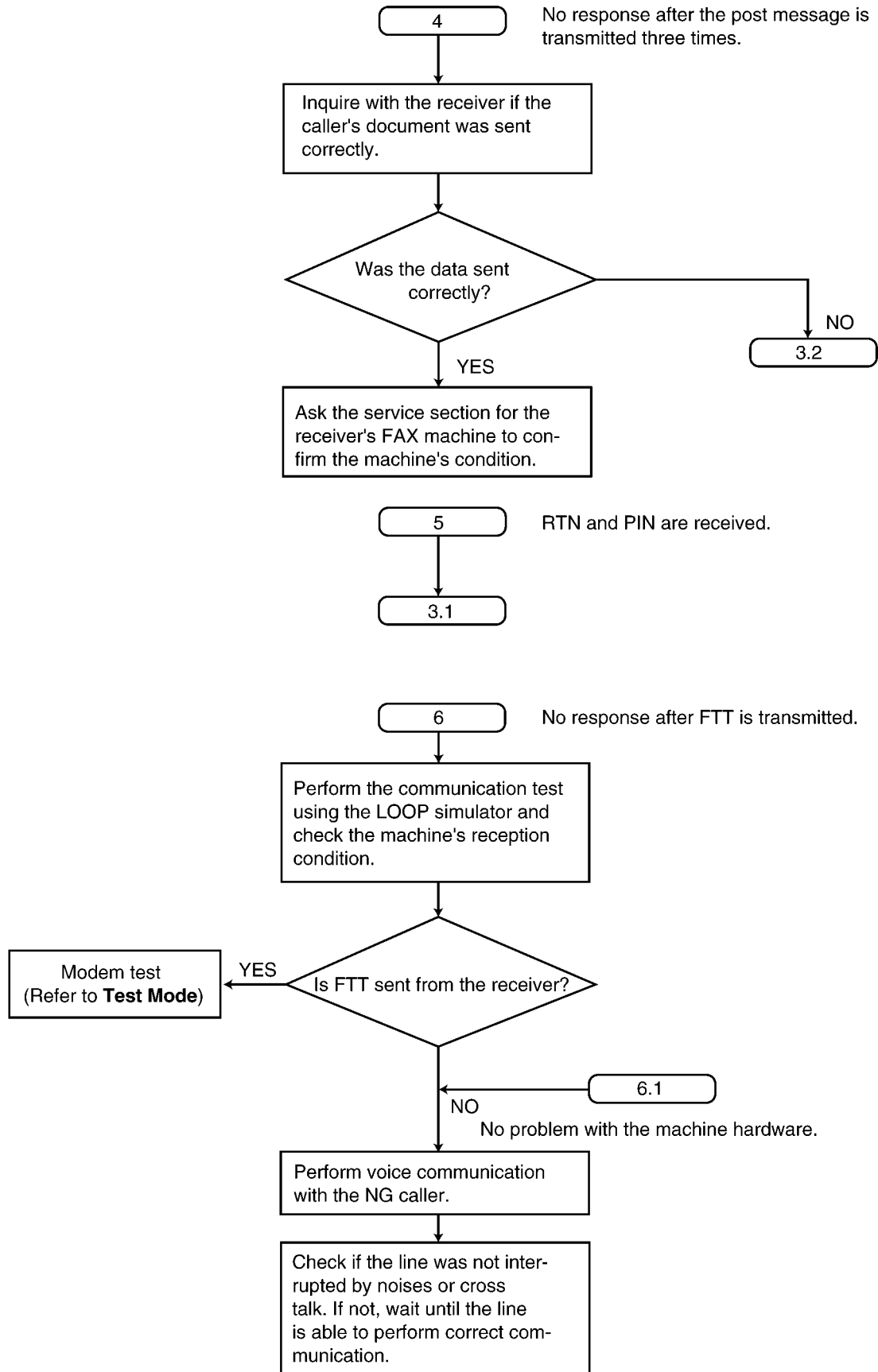

REFERENCE:
Test Mode (P.58)

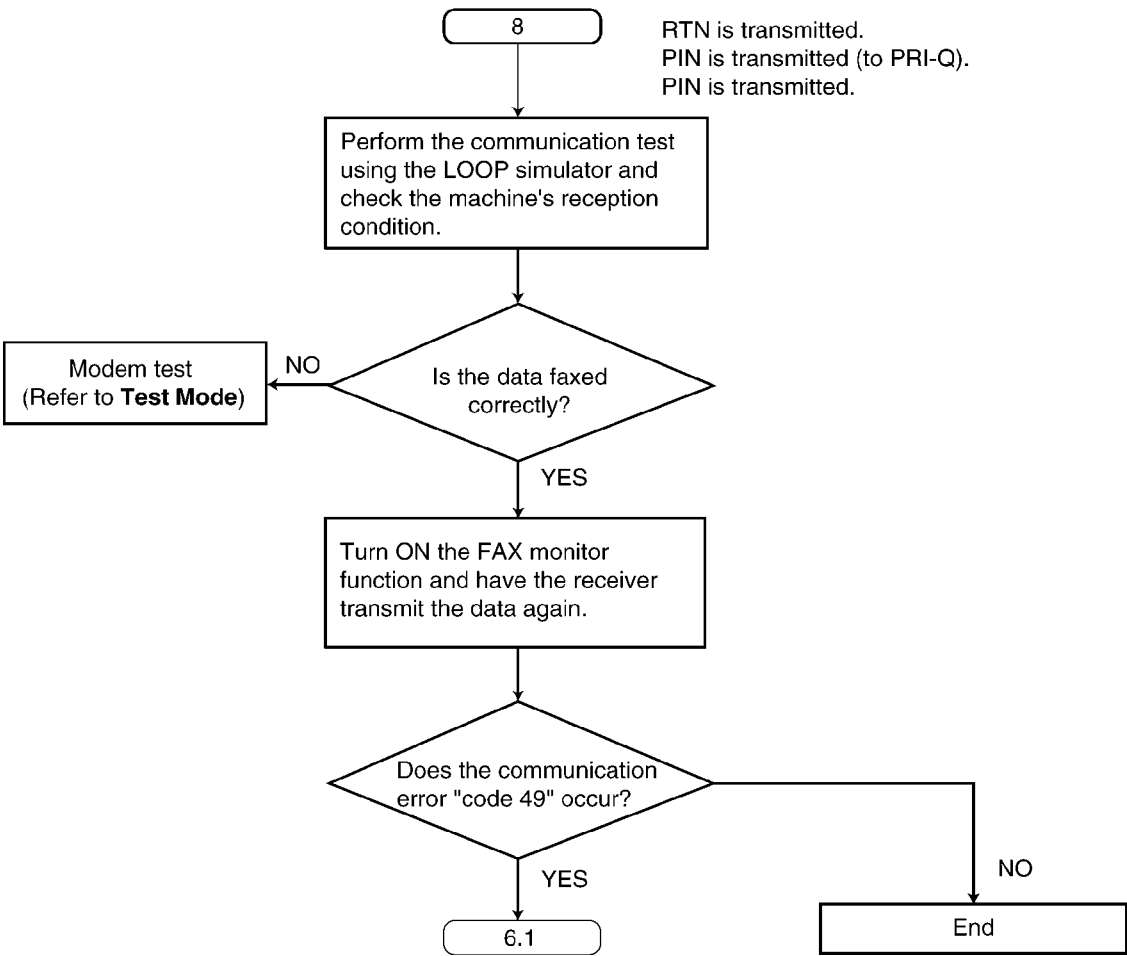
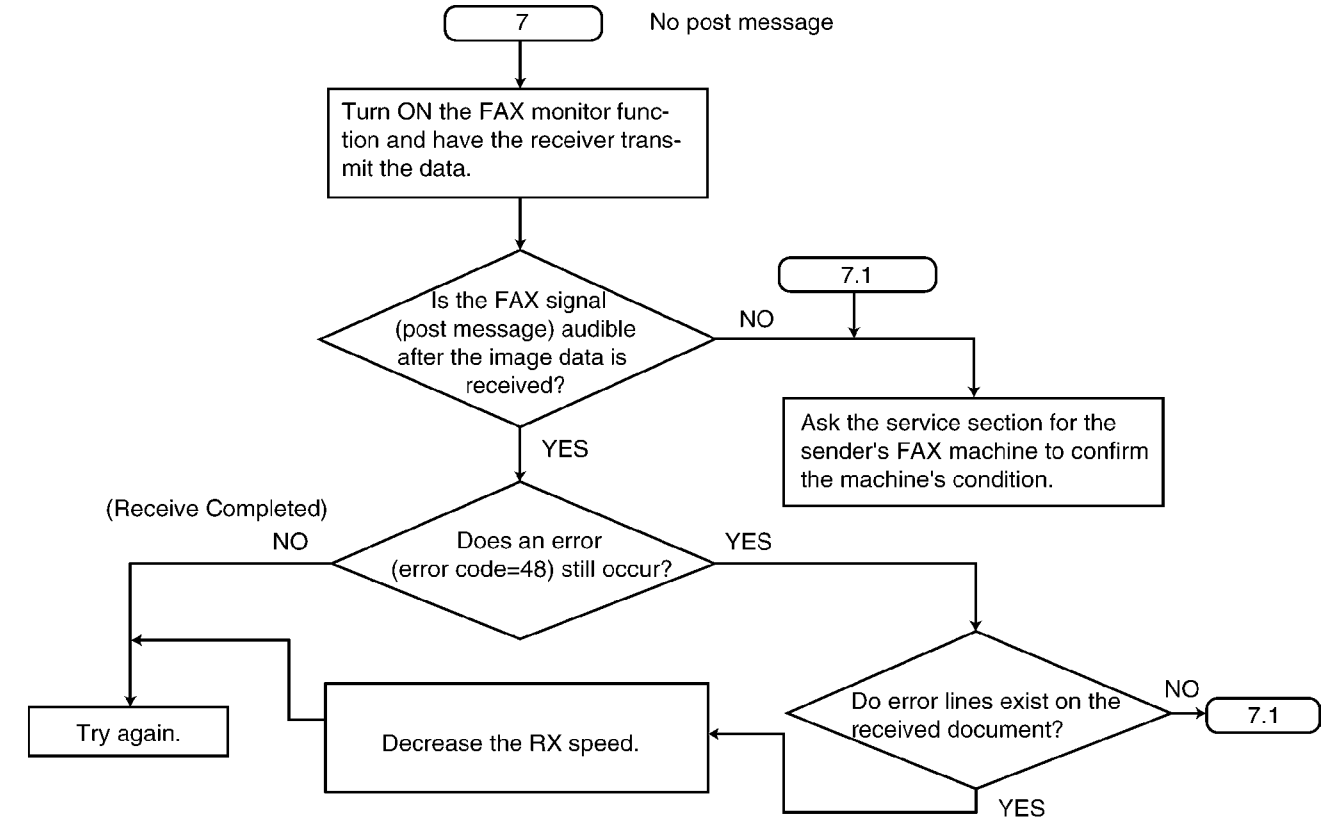

REFERENCE:
Test Mode (P.58)

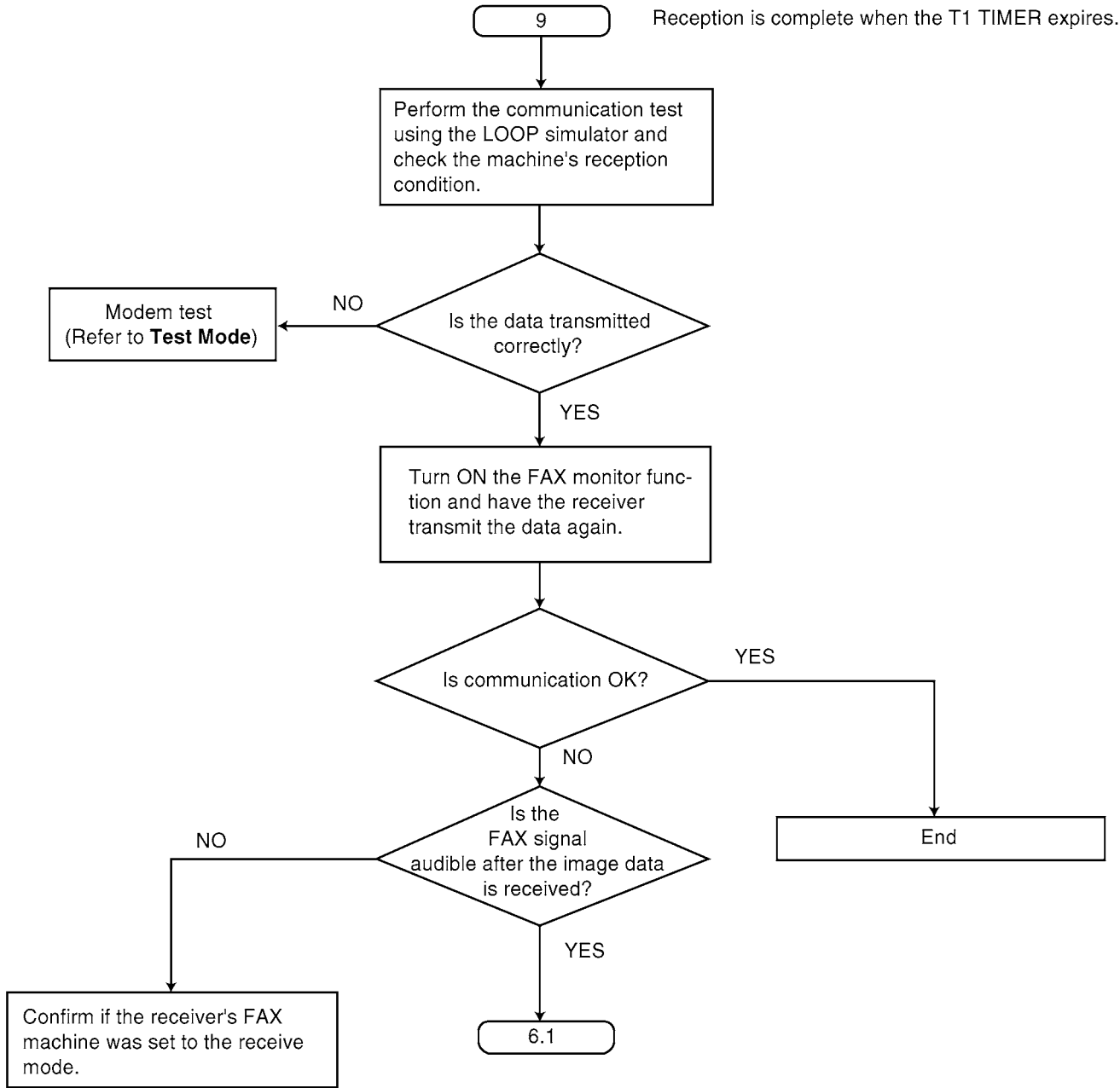

REFERENCE:
Test Mode (P.58)

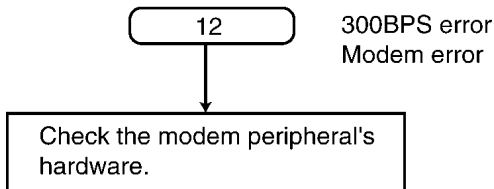
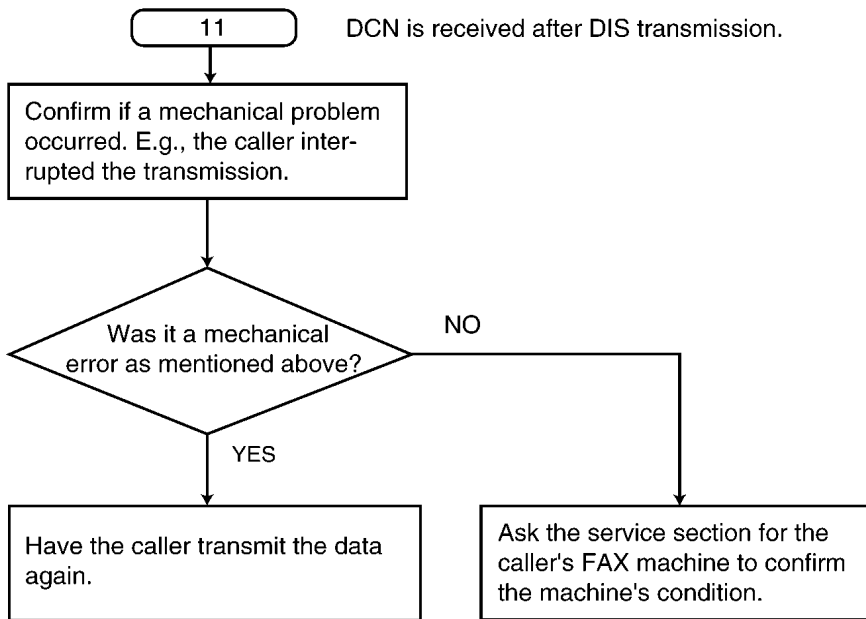
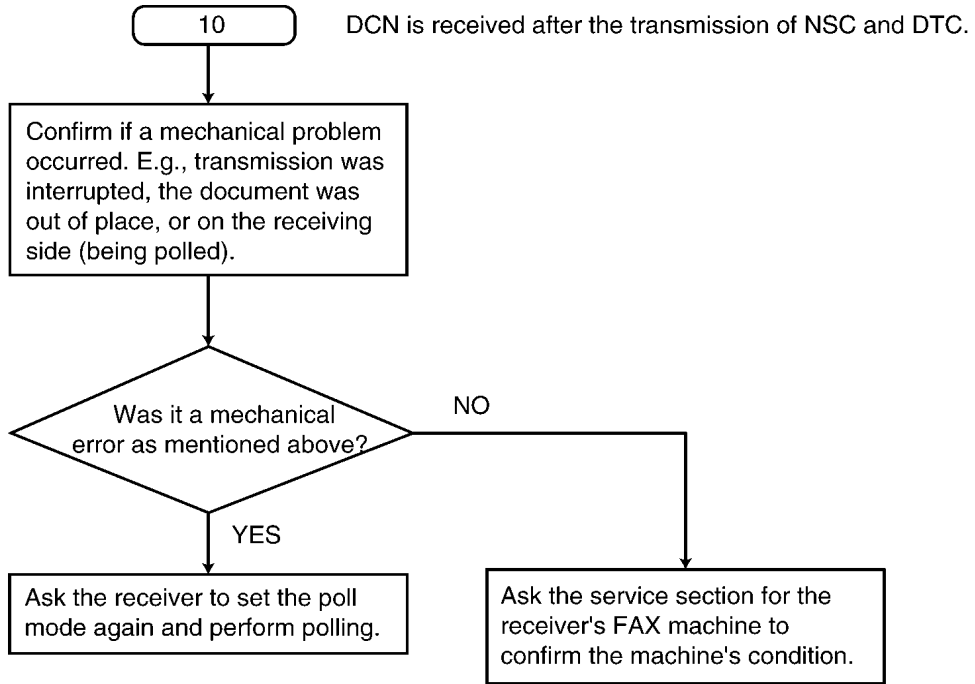

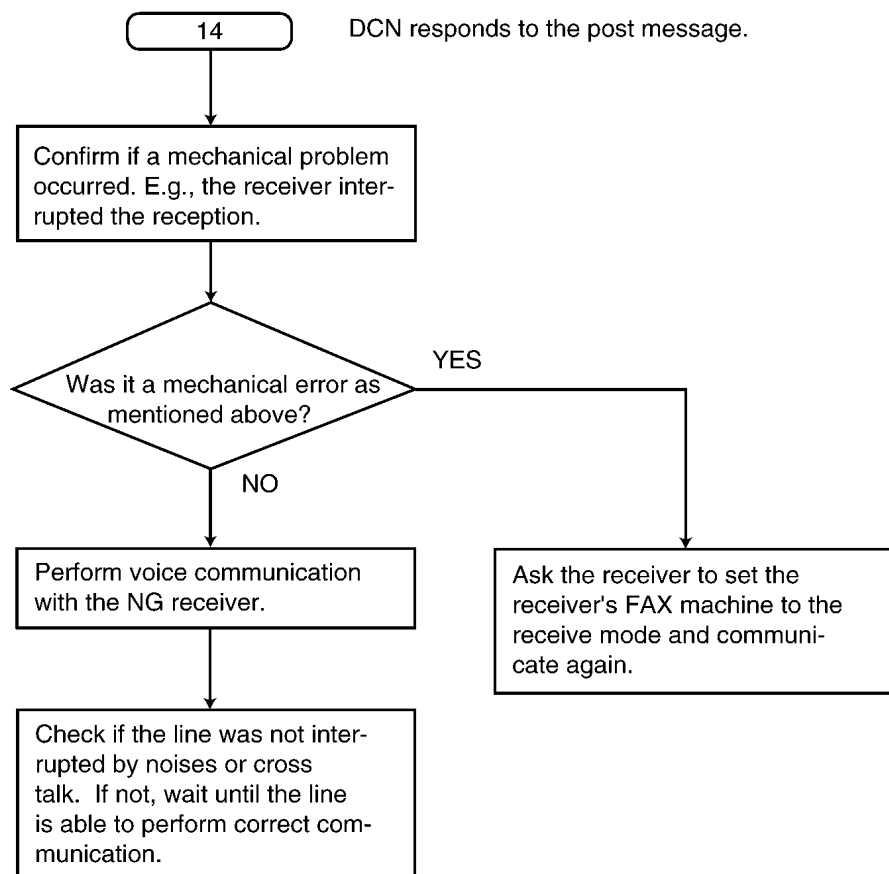
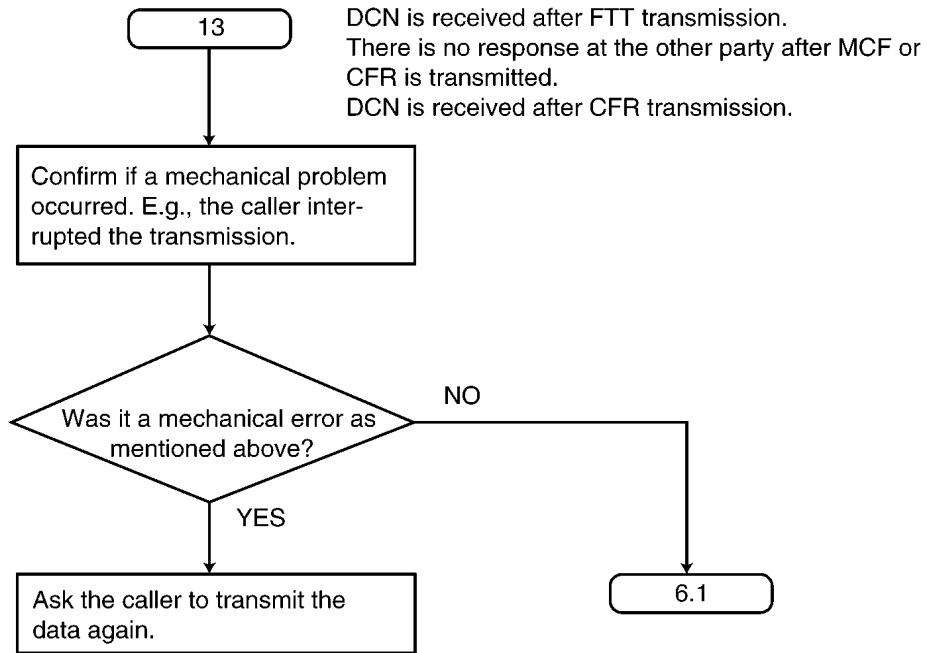

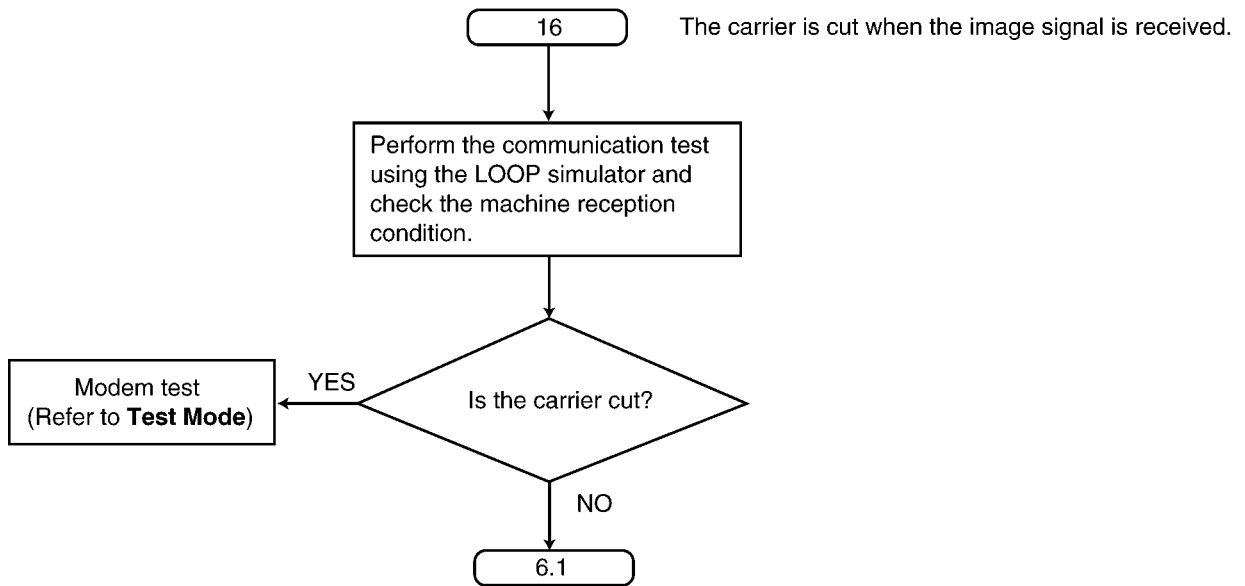
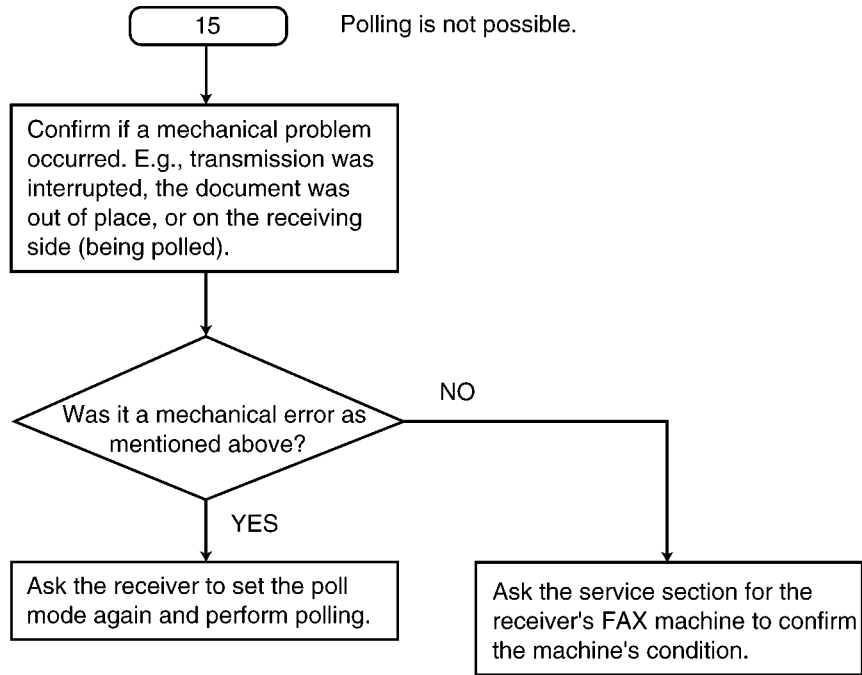

REFERENCE:
Test Mode (P.58)

12.3.2. Special Service Journal Report

Journal 2 and Journal 3 shown below, which are special journals giving the additional detailed information about the latest 35 communications, can be printed by Service Code 881 or 882. Remote printing function for the journal reports (JOURNAL, JOURNAL 2 and JOURNAL 3) is also available for service technicians. (Refer to **Remote Programming** (P.97).) The JOURNAL report only gives you basic information about a communication, but the other two journal reports provide different information on the same item (communication).

23 Jan. 2006 09:51AM
YOUR LOGO :
YOUR FAX NO:

NO.	OTHER FACSIMILE	START TIME	USAGE TIME	MODE	PAGES	RESULT	*CODE
01	3332222	Jan. 21 02:14PM	00'45	SND	01	OK	
02	9998765	Jan. 21 03:17PM	00'58	SND	02	OK	
03	John	Jan. 21 05:18PM	00'48	RCV	01	OK	
04	555556677	Jan. 22 10:35AM	02'45	RCV	03	COMMUNICATION ERROR	(46)

23 Jan. 2006 09:51AM

NO.	(1) RCV. MODE	(2) SPEED (CNT.)	(3) RESOLUTION	(4) RCV-TRIG. (CNT.)	(5) ERROR->MEMORY
01	TEL	9600BPS	STD.		
02	TEL	9600BPS	FINE		
03	FAX ONLY	7200BPS	STD.	FAX MOD	
04	FAX ONLY	9600BPS	STD.	CNG (0003)	

NO RESPONSE DISAPPEARED ON JOURNAL

NO.	(1) START TIME	(4) RCV MODE	(4) RCV-TRIG (CNT.)

YOUR LOGO
YOUR FAX NUMBER

23 Jan. 2006 09:51AM

NO.	(6) ENCODE	(7) MSLT	(8) EQM (RX)	(9) ERROR LINE (RX)	(10) MAKER CODE
01	MH	20msec	0000	00000	79
02	MH	20msec	0000	00000	00
03	MR	20msec	1200	00013	00
04	MR	20msec	0000	00000	00

HOW TO READ JOURNAL REPORTS:

Example:

- Look at **NO. 01** in the JOURNAL. If you want to know about the details about that item, see **NO. 01** in the JOURNAL 2 and the JOURNAL 3. You can get the following information.
 - * MODE: Fax transmission
 - * RCV. MODE: TEL
 - * TX SPEED: 9.6 kbps
 - * RESOLUTION: standard
 - * ENCODE: MH
 - * MAKER CODE: 79
- Look at **NO. 04** in the JOURNAL 2. CNG (0003) indicates that the CNG signal has been received three times since the purchase date. For further details, see **Journal 2** (P.85) and **Journal 3** (P.86).

12.3.2.1. Journal 2

Refer to JOURNAL 2 in **Printout Example** (P.86).

Journal 2 displays the additional detailed information about the last 35 communications.

Descriptions:

(1) RCV. MODE

Indicates which receive mode the unit was in when the unit received a fax message.

This information is also displayed when the unit transmitted a fax message.

(2) SPEED

Indicates the speed of the communication. If multiple pages are transmitted or received, it indicates the last page's communication speed. If there is a communication error, "?" is displayed.

(3) RESOLUTION

Indicates the resolution of the communication. If multiple pages are transmitted or received, it indicates the last page's resolution. If there is a communication error, "?" is displayed.

(4) RCV-TRIG. (CNT.)

Indicates the trigger that causes the unit to switch to the fax receive mode. The available options are listed in JOURNAL 2 in **Printout Example** (P.86). The values in parentheses indicate how many times the trigger has been used. (For example, "0003" means three times.)

No.	Display	Function
1	FAX MODE	Means the unit received a fax message in the FAX mode.
2	MAN RCV	Means the unit received a fax message by manual operation.
3	FRN RCV	Means the unit received a fax message by friendly signal detection.
4	VOX	Means the unit detected silence or no voice.
5	RMT DTMF	Means the unit detected DTMF (Remote Fax activation code) entered remotely.
6	PAL DTMF	Means the unit detected DTMF (Remote Fax activation code) entered by a parallel connected telephone.
7	TURN-ON	Means the unit started to receive after 10 rings. (Remote Turn On: Service Code #573)
8	TIME OUT	Means the unit started to receive after Ring Time Out in the EXT-TAM or TEL/FAX mode.
9	IDENT	Means the unit detected Ring Detection.
10	CNG OGM	Means the unit detected the CNG while it was sending the Dummy Ring Back Tone in the TEL/FAX mode. OR Means the unit detected the CNG while it was sending the OGM in the ANS/FAX mode.
11	CNG ICM	Means the unit detected the CNG while it was recording the ICM in the ANS/FAX mode.

(5) ERROR→MEMORY

Indicates the reason why the unit received a fax message in memory.

If you look at No.11 in the JOURNAL 2 in **Printout Example** (P.86), it shows the fax message was received in memory due to "PAPER OUT" error.

NO RESPONSE DISAPPEARED ON JOURNAL

The "NO RESPONSE DISAPPEARED ON JOURNAL" displays the information about the last 10 communications terminated by "No Response". (Some of the communications terminated by "No Response" were not displayed in the JOURNAL.)

When a fax transmission cannot be performed because the other party's unit is set to the TEL mode, "No response" will be printed.

12.3.2.2. Journal 3

Refer to JOURNAL 3 in **Printout Example** (P.86).

Descriptions:

(6) ENCODE

Compression Code: MH/MR

(7) MSLT

MSLT means Minimum Scan Line Time. Used only at the factory.

(8) EQM

EQM means Eye Quality Monitor. Used only at the factory.

(9) ERROR LINE(RX)

When an error occurs while receiving a fax, this shows the number of error lines.

(10) MAKER CODE

This shows a 2 digit code of the other party's fax machine brand.

0E: "KX" model

00: Unknown

79: "UF" model

19: "Xerox" model

12.3.2.3. Printout Example

JOURNAL2

25 MAR. 2006 01:59PM

NO.	RCU MODE	SPEED (CNT.)	RESOLUTION	RCU-TRIG. (CNT.)	ERROR->MEMORY
01	FAX ONLY	9600BPS	FINE.	FAX MOD	
02	FAX ONLY	9600BPS	STD.	FAX MOD	
03	FAX ONLY	9600BPS	FINE.		
04	FAX ONLY	9600BPS	FINE.	FAX MOD	
05	FAX ONLY	9600BPS	FINE.	FAX MOD	
06	FAX ONLY	9600BPS	FINE.	FAX MOD	
07	FAX ONLY	9600BPS	FINE.		
08	FAX ONLY	9600BPS	FINE.		
09	FAX ONLY	9600BPS	FINE.		
10	FAX ONLY	9600BPS	STD.	FAX MOD	
11	FAX ONLY	9600BPS	FINE.	FAX MOD	PAPER OUT
12	FAX ONLY	9600BPS	STD.	FAX MOD	
13	FAX ONLY	9600BPS	STD.		
14	FAX ONLY	?	?		
15	FAX ONLY	?	?		
16	FAX ONLY	?	?		
17	FAX ONLY	9600BPS	STD.		
18	FAX ONLY	9600BPS	FINE.	FAX MOD	
19	FAX ONLY	9600BPS	STD.	FAX MOD	
20	FAX ONLY	9600BPS	S-FINE.		
21	FAX ONLY	9600BPS	FINE.		
22	FAX ONLY	9600BPS	FINE.	FAX MOD	
23	FAX ONLY	?	?	FAX MOD	
24	FAX ONLY	9600BPS	STD.	FAX MOD	
25	FAX ONLY	9600BPS	STD.	FAX MOD	
26	FAX ONLY	9600BPS	FINE.	FAX MOD	
27	FAX ONLY	9600BPS	FINE.		
28	FAX ONLY	9600BPS	STD.	FAX MOD	
29	FAX ONLY	9600BPS	FINE.	FAX MOD	
30	FAX ONLY	9600BPS	S-FINE.	FAX MOD	
31	FAX ONLY	9600BPS	STD.	FAX MOD	
32	FAX ONLY	9600BPS	STD.	FAX MOD	
33	FAX ONLY	?	?	FAX MOD	
34	FAX ONLY	9600BPS	STD.	FAX MOD	
35	FAX ONLY	9600BPS	STD.	FAX MOD	

NO RESPONSE DISAPPEARED ON JOURNAL

NO.	START TIME	RCU MODE	RCU-TRIG. (CNT.)
-----	------------	----------	------------------

JOURNAL3

25 MAR. 2006 01:58PM

NO.	ENCODE	MSLT	EQM(RX)	ERROR	LINE(RX)	MAKER CODE
01	MR	10msec	007A	00000		0E
02	MR	20msec	016B	00000		00
03	MH	10msec	0000	00000		00
04	MR	20msec	019B	00003		00
05	MR	20msec	0156	00011		00
06	MR	20msec	0113	00000		00
07	MR	5msec	0000	00000		79
08	MR	5msec	0000	00000		79
09	MR	0msec	0000	00000		19
10	MR	20msec	0100	00000		00
11	MR	10msec	0073	00000		0E
12	MR	20msec	012B	00000		00
13	MH	20msec	0000	00000		79
14	MH	20msec	0000	00000		00
15	MH	20msec	0000	00000		00
16	MH	20msec	0000	00000		00
17	MR	5msec	0000	00000		79
18	MR	10msec	00AB	00004		0E
19	MR	20msec	0124	00000		00
20	MR	20msec	0000	00000		00
21	MR	20msec	0000	00000		00
22	MR	20msec	0135	00000		00
23	MR	20msec	0000	00000		00
24	MR	20msec	01BC	00000		00
25	MR	20msec	01AC	00000		00
26	MR	20msec	020F	00000		00
27	MR	10msec	0000	00000		0E
28	MR	20msec	01DF	00000		00
29	MR	20msec	01EA	00000		00
30	MR	20msec	00CD	00000		00
31	MR	20msec	02F8	00000		0E
32	MR	10msec	04F8	00000		0E
33	MR	10msec	0000	00000		00
34	MR	20msec	03B6	00000		0E
35	MH	20msec	00E0	00000		00

12.3.3. Communication Section

Find the problem in the table shown below, and refer to the corresponding troubleshooting procedure in **Defective Facsimile Section** (P.89).

No.	Symptom	Reference Content	Possible cause
1	The paper is not fed properly when faxing. (Not in the copy mode.)	Transmit Problem (P.89)	Problem with the feeding mechanism. Refer to ADF (Auto Document Feed) Section (P.103).
2	The fax usually transmits successfully but sometimes fails. (The unit can copy documents.)	Sometime there is a transmit problem (P.90)	Problem with the service line or with the receiver's fax.
3	The fax usually receives successfully but sometimes fails. (The unit can copy documents.)	Receive Problem (P.91)	Problem with the service line or with the transmitter's fax.
4	The fax completely fails to transmit or receive. (The unit can copy documents.)	The unit can copy, but cannot transmit / receive (P.92)	Problem with the electric circuit.
5	The fax fails either to transmit or receive when making a long distance or an international call. (The unit can copy documents.)	The unit can copy, but cannot either transmit/receive long distance or international communications (P.93)	Problem with the service line.
6	The fax image is poor when transmitting or receiving during a long distance or an international call.	The unit can copy, but the transmission and reception image are incorrect (P.95)	
7	No.1~No.5	<ul style="list-style-type: none"> • The troubleshooting procedure for each error code will be printed on the communication result report. • Error Messages-Report (P.75) 	

12.3.3.1. Defective Facsimile Section

12.3.3.1.1. Transmit Problem

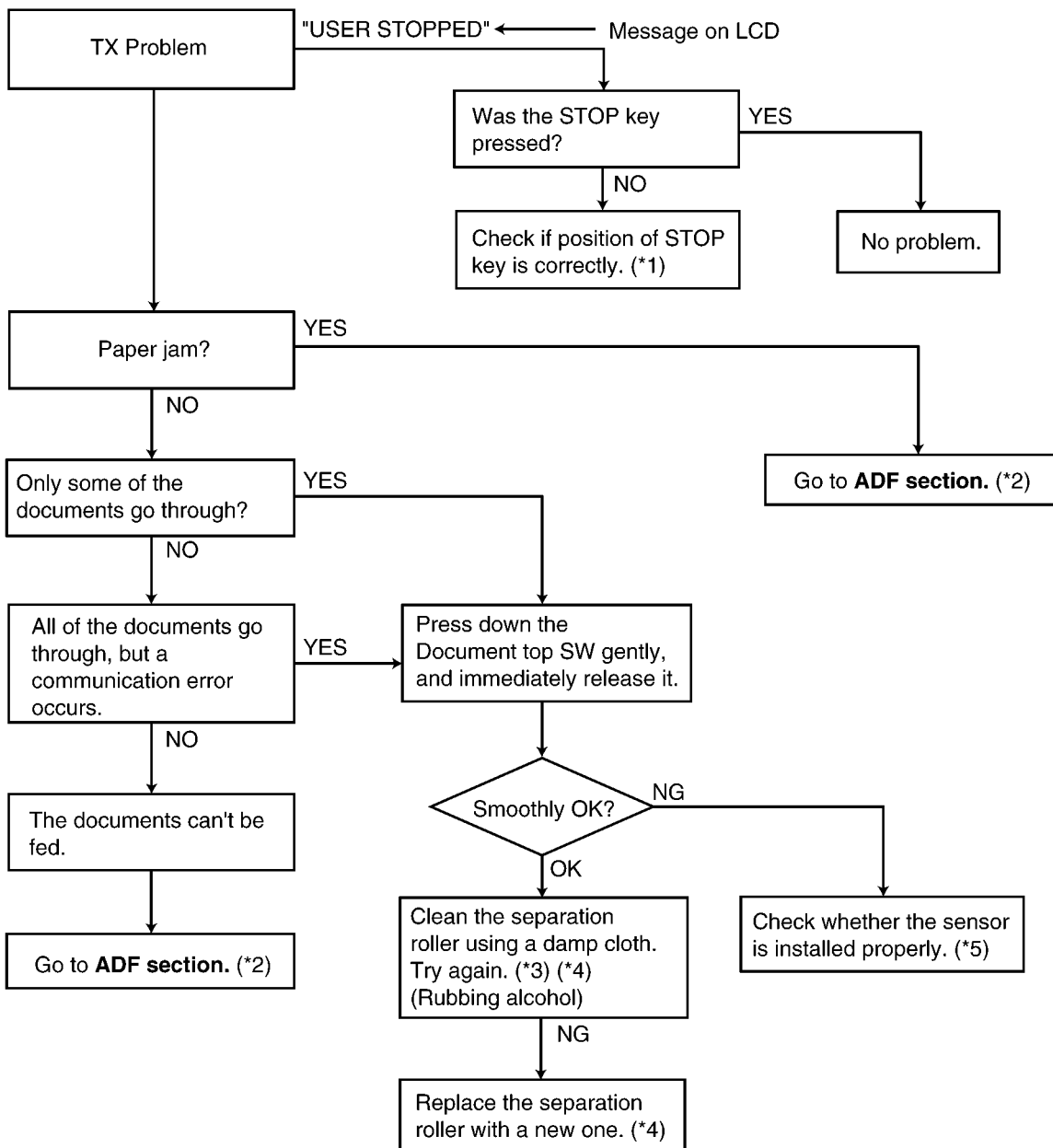

REFERENCE:

- (*1): Operation Panel Section (P.131)
- (*2): ADF (Auto Document Feed) Section (P.103)
- (*3): Maintenance (P.163)
- (*4): How to Remove the Gear Block and Separation Roller (P.146)
- (*5): How to Remove the Operation Board and LCD (P.155)

12.3.3.1.2. Sometime there is a transmit problem

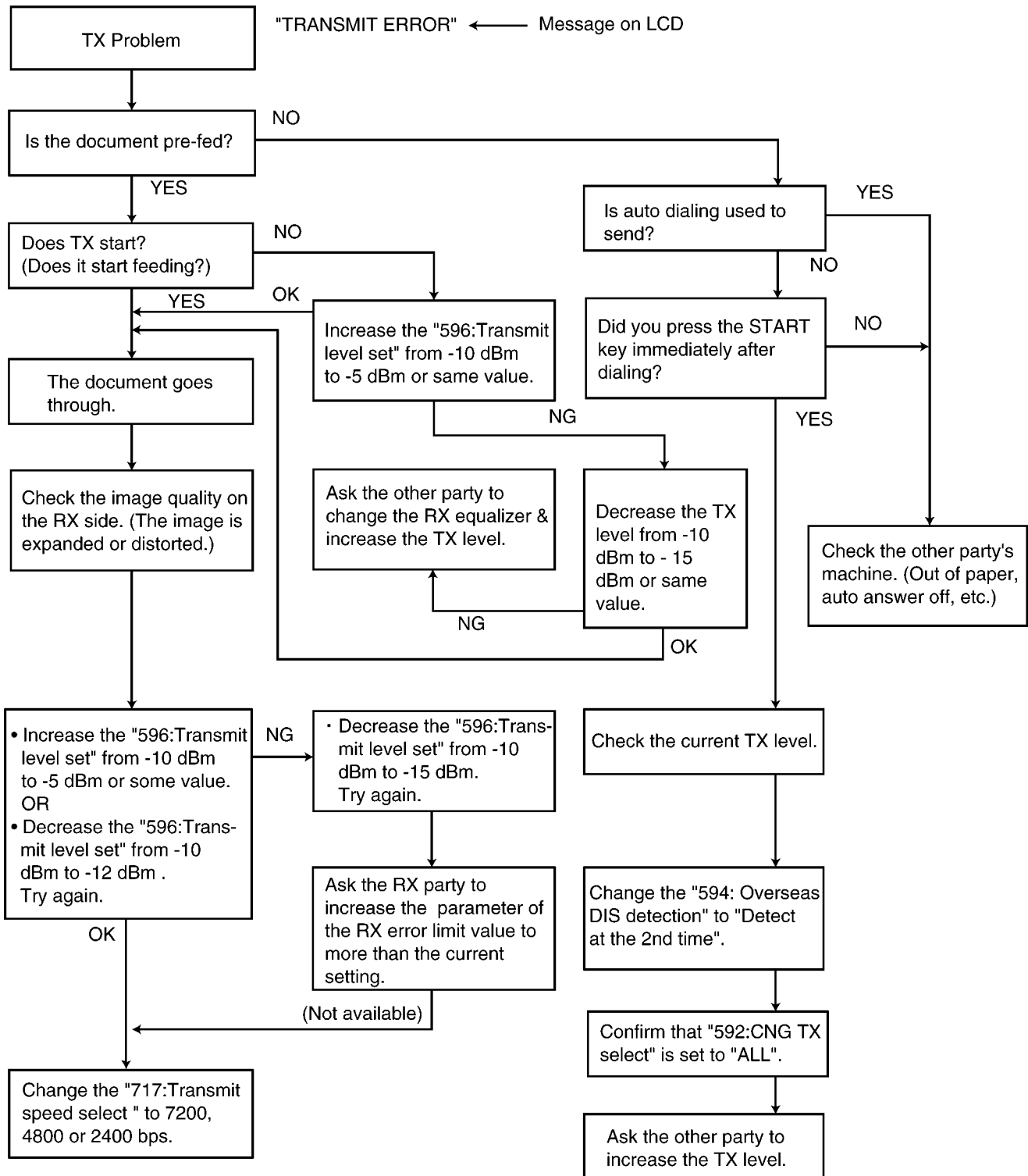

Note:

"596: Transmit level set" represents a service code. (Refer to **Service Function Table**(P.63).)

12.3.3.1.3. Receive Problem

First confirm whether the recording paper is installed properly or not before starting troubleshooting. (Refer to "Remarks".)

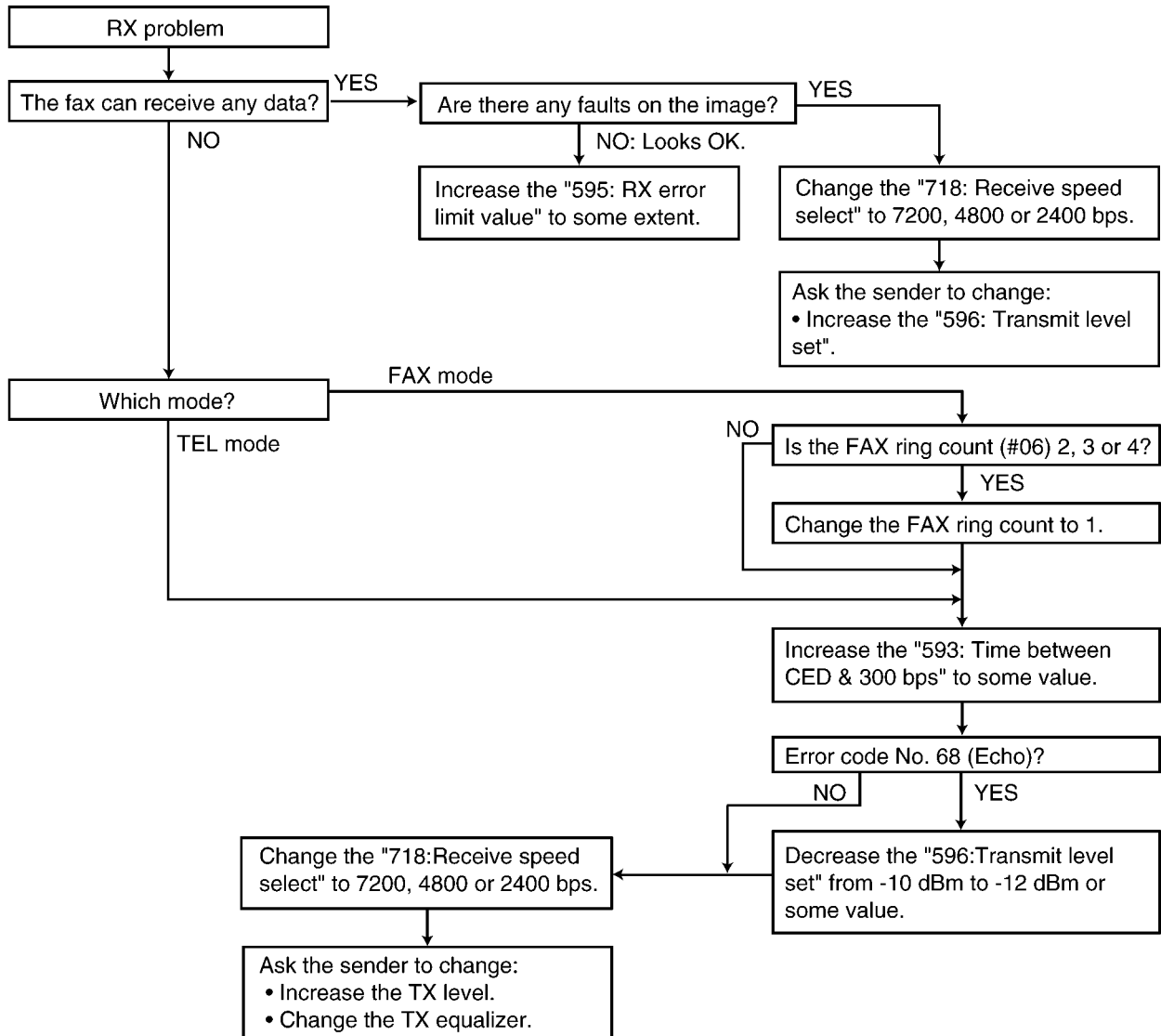

Note:

- "596: Transmit level set" represents a service code. (Refer to **Service Function Table** (P.63).)
- #06 : Refer to for **Program Mode Table** (P.98) Fax ring count.

Remarks:

Regarding the reception problem, we have investigated the conceivable causes in the flow chart except for the software-related errors. However, some troubles may occur due to the software-related problems such as "OUT OF PAPER" when the fax switches to the memory receiving mode and the memory capacity becomes full of the unprintable data. In this case, error messages [MEMORY FULL] and its main cause, for example "CHECK PAPER" are displayed on the LCD. Once you solve the main problem, [MEMORY FULL] will be cancelled and the reception problem will be resolved.

LCD display messages indicating the error causes are shown below.

CHECK PAPER

COVER OPEN

UNIT OVERHEATED (COVER OPEN, etc.)...Reset the unit.

PAPER JAMMED

CHECK FILM

Please refer to **Error Messages-Display** (P.73) for the above items. If it turns out to be a hardware deformity, please check each sensor. (Refer to **Test Mode** (P.58).)

12.3.3.1.4. The unit can copy, but cannot transmit / receive

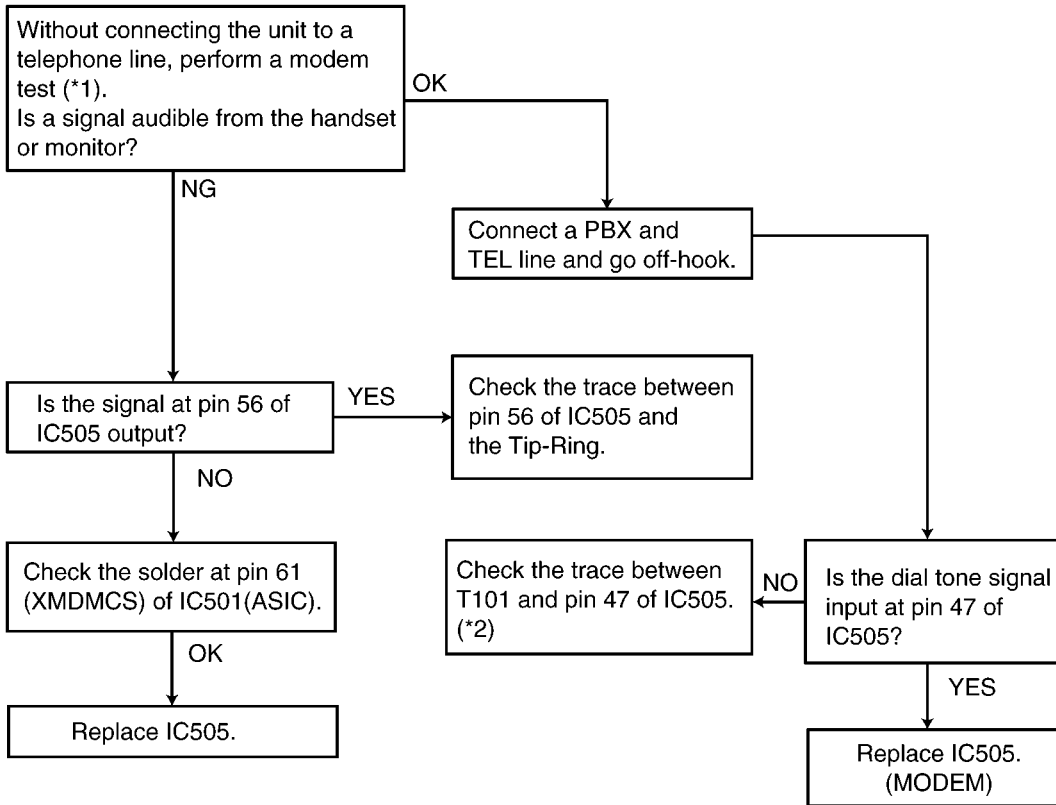

REFERENCE:

(*1): **Test Mode** (P.58)

(*2): **Analog Board Section** (P.123)

12.3.3.1.5. The unit can copy, but cannot either transmit/receive long distance or international communications

The following two causes can be considered for this symptom.

Cause 1:

The other party is executing automatic dialling, the call has been received by this unit, and the CED or DIS signal response time is too long. (In most cases, this unit detects the CNG signal and can respond to CED or DIS.) (According to the ITU-T standard, the communication procedure is cancelled when there is no response from the other party within 35 sec, so that the other party releases the line.)

(Response Time)

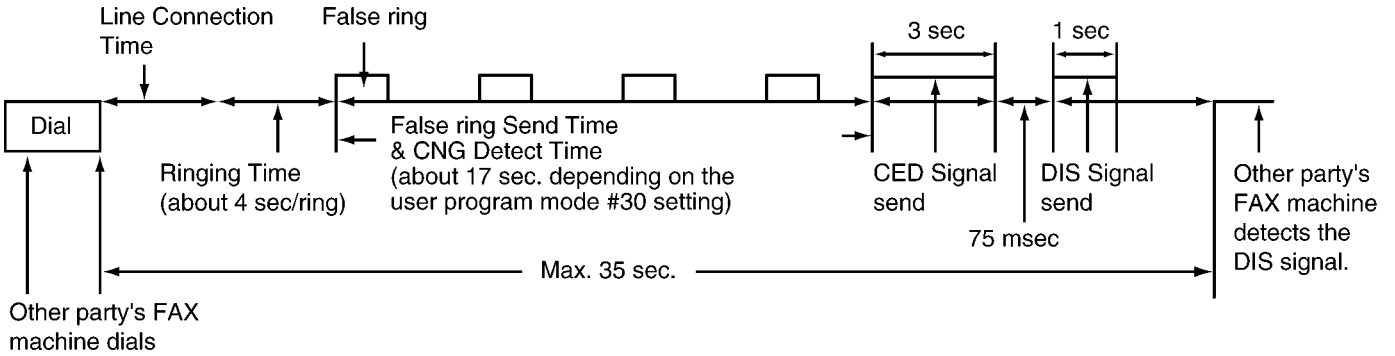

(Cause and Countermeasure)

As shown in the chart above, the total handshaking time must be reduced, but because of the long distance connection and linking of several stations, the line connection time cannot be reduced. Accordingly, the following countermeasures should be tried. (A)... As the 35 sec. count is started directly after dialling or directly after the START button has been pressed for models with a START button, the other party should be called manually, if possible. Another possibility is entering two pauses at the end of the auto dial number on the transmission side. Then the count start time can be delayed for 2 pauses (about 10 sec.).

Cause 2:

Erroneous detection because of an echo or an echo canceler.

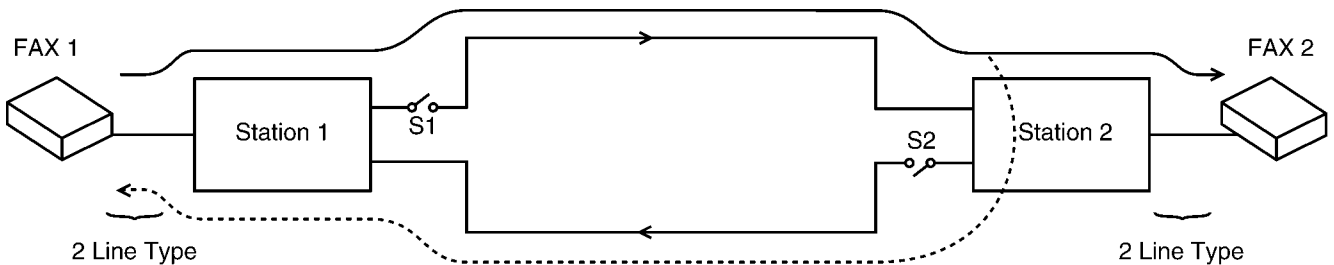

(Echo/Echo Canceler)

The signal from FAX1 reaches FAX2 via stations 1 and 2, but the reflection signal at station 2 also returns via station 1 (echo). As the distance between station 1 and station 2 is far, the echo returns to FAX 1 at a max of 600 msec after transmission. There is a possibility that this signal is detected erroneously as the signal from FAX2. For a normal call, there is also a possibility that the echo of their own voice will make the call difficult to understand. For this reason, each station (station 1 and station 2) attaches echo cancelers (S1 and S2) for international lines or long distance lines. For the echo canceler, the level of the transmission signal from FAX 1 is compared with the level of the reception signal from FAX2. When the transmission signal is larger, S1 is closed while S2 is opened when it is smaller. In other words, for transmission from FAX1, S1 is closed and S2 is open, so that the echo does not return to FAX1.

(Causes and Countermeasures)

No.	Countermeasure Side	Echo Communication Problem Example	Countermeasure	Service Code
1	Sending side	Some time is needed to compare the level of the receiving and sending signals for the echo canceler. The header of the training signal lacks due to a switching delay to close S1.	Add a dummy signal to the beginning of the training signal.	Service code (521) (International mode select) This countermeasure becomes the default value.
2	Receiving side	The echo canceler function stops according to a CED signal frequency of 2100Hz (S1 and S2 are both ON), a DIS signal is returned as an echo, and a DCS signal from the sending side overlaps the DIS echo. Then the receiving side FAX cannot retrieve the DCS signal. (Refer to Fig. a)	Change to a 1100Hz CED signal frequency. (Refer to Fig. b)	Service code (520) (CED frequency select)
	Receiving side		Change the regular rime of 75 msec between the CED signal and DIS signal to 500 msec. This will give at least 250 msec to recover the echo canceler operation. (Refer to Fig. c)	Service code (593) (Time between CED and 300 bps)
	Sending side		The sending side FAX sends a DCS signal not after receiving the 1st DIS signal but after receiving the 2nd DIS signal. (Refer to Fig. d)	Service code (594) (Overseas DIS detection select)
3	Sending side	Communication failure occurs in a long distance communication on the telephone line without an echo canceler.	Decrease the transmission level from -10 dBm to -15 dBm and the echo level will decrease.	Service code (596) (Transmit level set)
4	Sending side	or	Decrease the receiving sensitivity from -13 dBm to about -32 dBm so an echo signal will not received.	Service code (598) (Receiving sensitivity)
	Receiving side			
5	Sending side Receiving side	There are some cases (e.g. Mobil comms.) which cause the collision of TX / RX signals due to the delay / echo and noise of the network / terminal. (Refer to Fig. e)	Set additional Pause time (Service mode: code No. 774) in between the original and its repeated signals, to prevent the collision of the signals at both end.	Service code (774) (T4 timer)

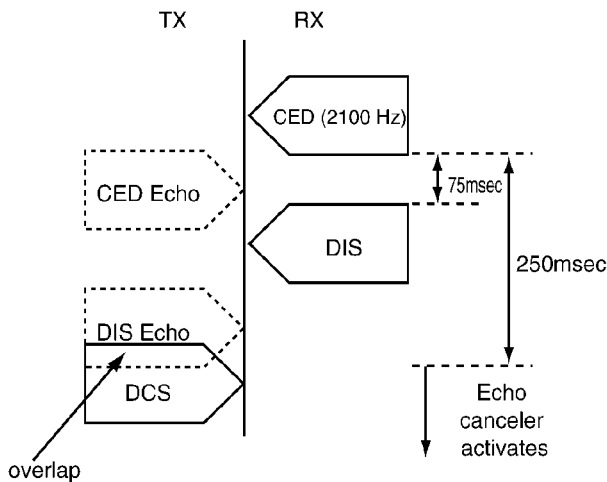

Fig. a

(Overlapping the Echo of the DIS signal and DCS signal)

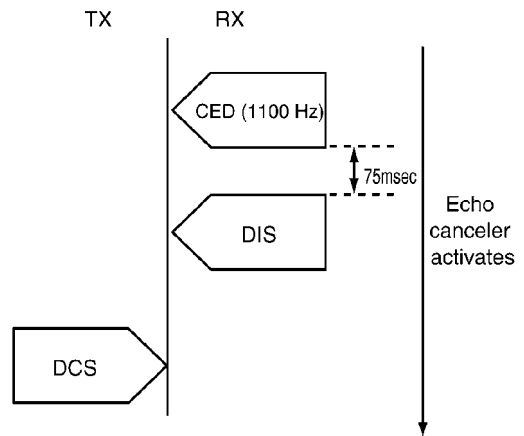

Fig. b

(Countermeasure by Changing the CED Frequency)

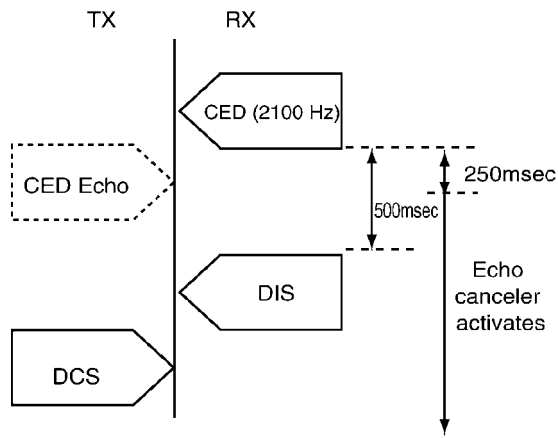

Fig. c

(Countermeasure by Changing the Interval Between CED and DIS)

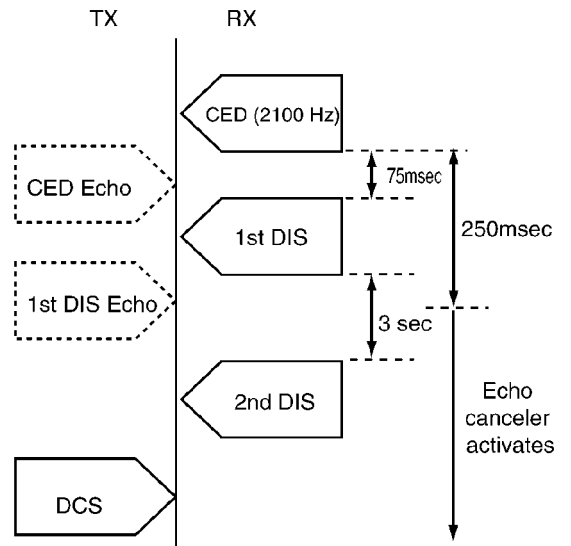
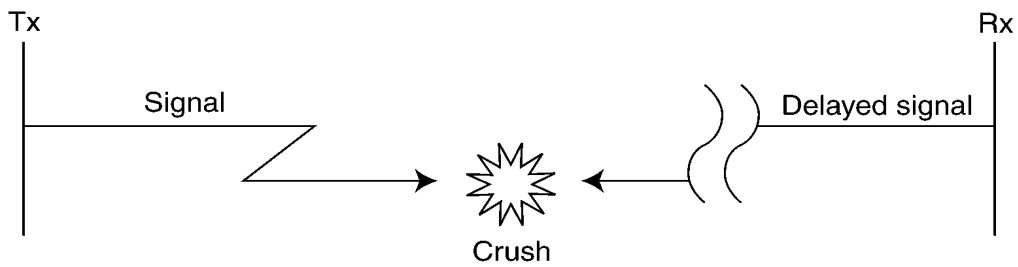

Fig. d

(Countermeasure by Ignoring the 1st DIS)

<TX side signal>	<RX side signal>	<Countermeasure>
2nd / 3rd DCS / Training	& delayed CFR / FTT	at TX side
2nd / 3rd EOP / EOM / MPS	& delayed MCF / PIP / PIN / RTP / RTN	at TX side
delayed DCS	& 2nd / 3rd / --- DIS	at RX side



(Fig. e)

12.3.3.1.6. The unit can copy, but the transmission and reception image are incorrect

(Long distance or international communication operation)

This symptom highly depends on the transmission and reception capability of the other FAX unit and the line conditions. The countermeasures for this unit are shown below.

Transmission Operation:

Set the transmitting speed to 4800BPS (service mode: code No. 717) or select the overseas mode.

Reception Operation:

If 80% or more of the reception is incorrect, set the receiving speed to 4800BPS. (Service mode: code No. 718)

- Refer to **Service Function Table** (P.63).

12.3.3.1.7. How to record fax signal by using PC

Recording FAX signal is one of the useful analysis measures to solve communication problems.
The way of recording easily by using PC is shown as follows.

1. Equipment

- 1 jig
- 1 PC (with LINE IN)
- 1 audio cord (mini jack supported)
- 2 tel cords

Parts No.	Parts Name & Description	Qt'y
PQJJ1T004Z	JACK1, JACK2	2
PQJJ1D010Z	PIN JACK	1
ECQE2155KF	CAPACITOR	2
or ECQE2E155KC		
MA4020	DIODE	2

2. Setting up

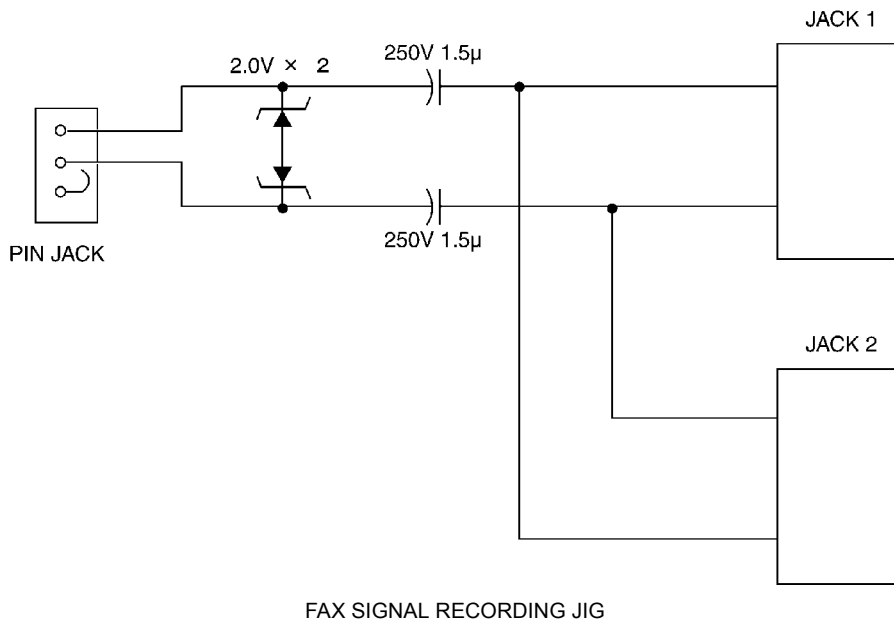

3. Connecting PC and JIG

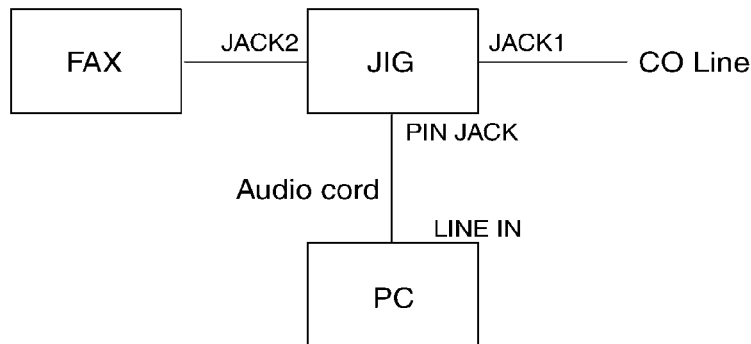

4. PC setting and recording

1. Set LINE IN to be valid in the volume control setting.
Refer to the PC instruction book.
2. Start up the PC software "SOUND RECORDER". (This software is bundled to Windows OS, which can create WAV file.)
Set the audio format "PCM 22.050kHz, 8bit, mono".
3. Click the record button and start recording after acquisition the signal.

Note:

- Not to be wind wave patterns on the wave monitor.
- Please compress the recording data when you send attaching to E-Mail because the data size will be so heavy.
- Any software which can create WAV files is available.

12.4. Remote Programming

If, after the call is connected, the customer describes the situation and it is determined that the problem can be corrected by making parameter changes, this function makes it possible to change parameters such as the user code and service code from another fax (using DTMF tones). Therefore, travel to the customer's location is not required. However, it is not possible to change all the parameters remotely (**Program Mode Table** (P.98)). The function used to accomplish this is remote programming.

First, in order to check the current status of the service code parameter, print out the setup list (code: 991) and the service list (code: 999) from the customer's fax machine.

Based on this, the parameters for the desired codes can be changed.

The procedure for changing and listing parameters is described on **Entering the Remote Programming Mode and Changing Service Codes** (P.97). Also, before exiting the remote programming mode, it is advisable to obtain a new list to confirm that the changes were made correctly.

Hints:

Since the connected telephone is in use during the remote programming mode, it may be helpful to ask the customer to switch to the speakerphone. This frees the customer from the need to remain right next to the fax while you are making parameter settings. When finished, inform the customer. Also note that in very noisy locations where the DTMF tones are not audible, the remote programming function will not work.

12.4.1. Entering the Remote Programming Mode and Changing Service Codes

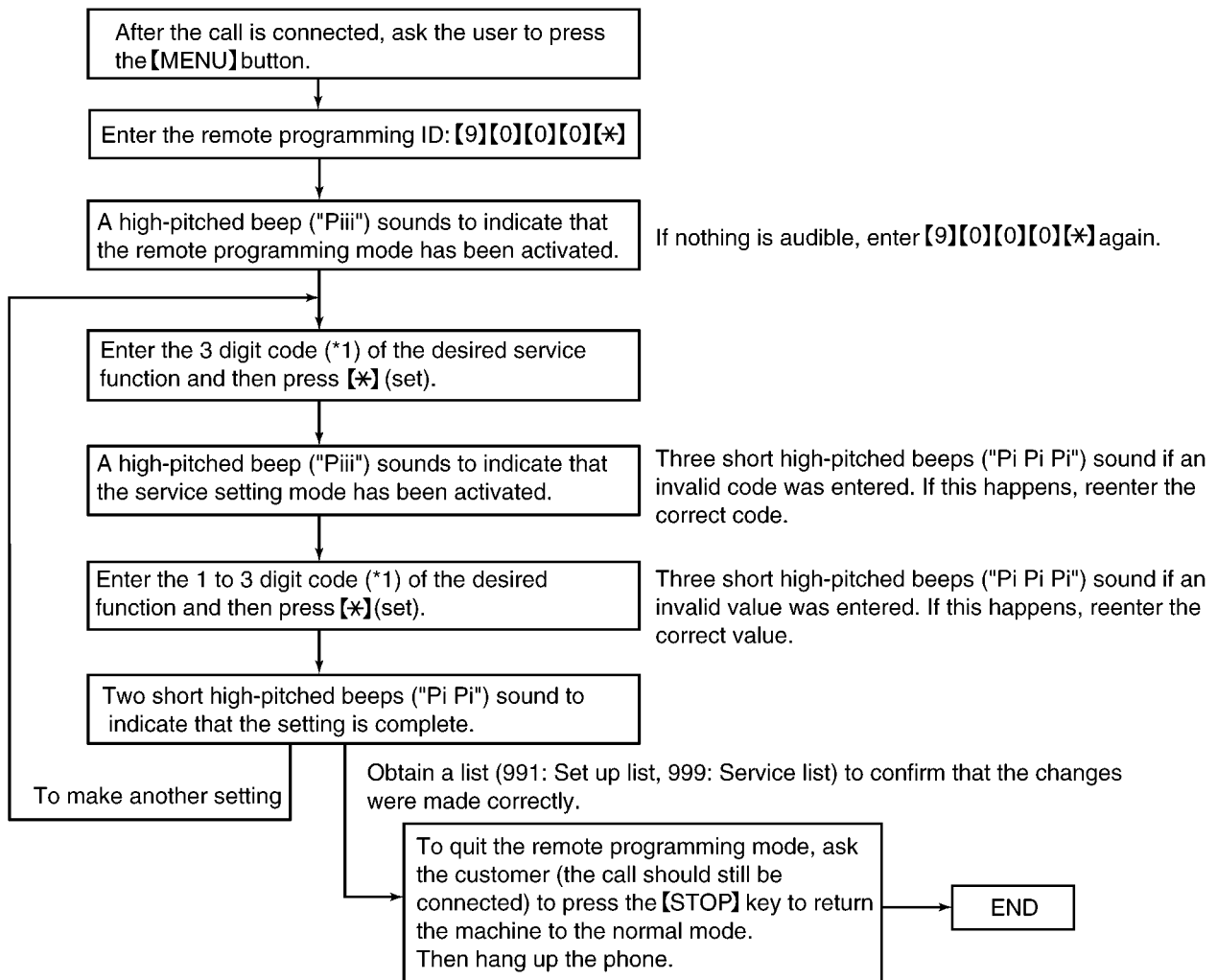

Note:

(*1): Refer to **Program Mode Table** (P.98)

12.4.2. Program Mode Table

Code	Function	Set Value	Default	Remote Setting
001	Set date and time	dd/mm/yy hh:mm	01/Jan/2006	NG
002	Your logo	-----	None	NG
003	Your FAX number	-----	None	NG
004	Print sending report	1:ERROR / 2:ON / 3:OFF	ERROR	OK
006	FAX ring count	1~9	2	OK
006	TAM/FAX ring count (KX-FP218)	2~7 / 0:TOLL SAVER	2	OK
010	Recording time (KX-FP218)	1:GREETING ONLY / 2:1MIN / 3:2MIN / 4:3MIN	3MIN	OK
011	Remote TAM ID (KX-FP218)	-----	ID=#11	NG
013	Dialling mode	1:Pulse / 2:Tone	Tone	OK
017	Ringer tone	TONE 1 / TONE 2 / TONE 3	TONE 1	NG
022	Journal auto print	1:ON / 2:OFF	ON	OK
023	Overseas mode	1:NEXT FAX / 2:ERROR / 3:OFF	ERROR	OK
025	Delayed transmission	ON / OFF	OFF	NG
026	Auto caller's list	1:ON / 2:OFF	OFF	OK
034	Quick scan	1:ON / 2:OFF	OFF	OK
036	RCV reduction	1:92% / 2:86% / 3:72% / 4:100%	92%	OK
039	LCD contrast	NORMAL / DARKER	NORMAL	NG
041	FAX activation code	ON / OFF	ON ID= * #9	NG
044	Memory receive alert	1:ON / 2:OFF	ON	OK
046	Friendly reception	1:ON / 2:OFF	ON	OK
047	Voice guidance (KX-FP218)	1:ON / 2:OFF	ON	OK
049	Auto disconnect	ON / OFF	ON CODE= * 0	NG
054	Greeting MSG. REC. time (KX-FP218)	1:16s / 2:60s	16s	OK
058	Scan contrast	1: Normal / 2: Darker/ 3: Light	Normal	OK
067	ICM monitor (KX-FP218)	1:ON / 2:OFF	ON	OK
068	ECM selection	1:ON / 2:OFF	ON	OK
072	Set recall mode	0: 80ms / 1:90ms / 2:100ms / 3: 110ms 4:160ms / 5:200ms / 6:250ms / 7:300ms 8: 400ms / 9: 600ms / 10:700ms / 11:900ms	600ms	OK
073	Manual answer mode	1:TEL / 2:TEL/FAX	TEL	OK
076	Connecting tone	1:ON / 2:OFF	ON	OK
077	Auto answer mode (KX-FP218)	2: FAX Only / 3:TAM/FAX	TAM/FAX	OK
078	TEL/FAX delayed ring	1~9	2	OK
080	Set default	YES / NO	NO	NG
501	Pause time set	001~600 x 100msec	030 x 100msec	OK
503	Dial speed	1:10pps / 2:20pps	10pps	OK
510	Vox time (KX-FP218)	1:8sec / 2:6sec / 3:4sec	6sec	OK
511	Vox sense (KX-FP218)	1:High / 2:Low	High	OK
514	Bell detection time	1~9 x 100msec	6 x 100msec	OK
520	CED frequency select	1:2100Hz / 2:1100Hz	2100Hz	OK
521	International mode select	1:ON / 2:OFF	ON	OK
522	Auto standby select	1:ON / 2:OFF	ON	OK
523	Receive equalizer select	1:0km / 2:1.8km / 3:3.6km / 4:7.2km	0km	OK
524	Transmission equalizer select	1:0km / 2:1.8km / 3:3.6km / 4:7.2km	0km	OK
544	Document feed position adjustment value set	1~9	5	OK
550	Memory clear	-----	-----	NG
551	ROM check	-----	-----	NG
552	DTMF signal tone test	1:ON / 2:OFF	OFF	OK
553	Monitor on FAX communication	1:OFF / 2:Phase B / 3:ALL	OFF	OK
554	Modem test	-----	-----	NG
555	Scanner test	-----	-----	NG
556	Motor test	-----	-----	NG
557	LED test	-----	-----	NG
558	LCD test	-----	-----	NG
559	Document jam detection	1:ON / 2:OFF	ON	OK
561	Key test	-----	-----	NG
567	T0 timer	001~255 sec	046	OK

Code	Function	Set Value	Default	Remote Setting
570	Break % select	1:61% 2:67%	61%	OK
571	ITS auto redial time set	00~99	11	OK
572	ITS auto redial line disconnection time set	001~999sec	040sec	OK
573	Remote turn-on ring number (KX-FP207)	00~99	10	OK
573	Remote turn-on ring number (KX-FP218)	00~99	10	OK
574	Dial tone detect check	1:ON / 2:OFF	OFF	OK
580	TAM continuous tone detection (KX-FP218)	1:ON / 2:OFF	ON	OK
590	FAX auto redial time set	00~99	05	OK
591	FAX auto redial line disconnection time set	001~999sec	065sec	OK
592	CNG transmit select	1:OFF / 2:ALL / 3:AUTO	ALL	OK
593	Time between CED and 300 bps	1:75ms / 2:500ms / 3:1sec	75ms	OK
594	Overseas DIS detection	1:1st / 2:2nd	1st	OK
595	Receive error limit value	1:5% / 2:10% / 3:15% / 4:20%	10%	OK
596	Transmit level set	-15~00dbm	-10dbm	OK
598*1	Receiving Sensitivity	-20~-48dbm	-42dbm	OK
599	ECM frame size	1:256 byte / 2:64 byte	256 byte	OK
710	Memory clear except History data	-----	-----	NG
717	Transmit speed select (KX-FP207)	1:9600/ 2:7200/ 3:4800/ 4:2400	9600bps	OK
717	Transmit speed select (KX-FP218)	1:14400 / 2:12000 / 3:9600/4:7200/ 5:4800/ 6:2400	14400bps	OK
718	Receive speed select (KX-FP207)	1:9600/ 2:7200/ 3:4800/ 4:2400	9600bps	OK
718	Receive speed select (KX-FP218)	1:14400 / 2:12000 / 3:9600/4:7200/ 5:4800/ 6:2400	14400bps	OK
722	Redial tone detect	1:ON / 2:OFF	ON	OK
745	Power on film feed	1:ON / 2:OFF	ON	OK
763	CNG detect time for friendly reception	1:10s / 2:20s / 3:30s	30s	OK
773	DIS-DCS interval	1:500msec / 2:200msec	200ms	OK
774	T4 timer	00~99 x 100ms	00ms	OK
784	Voice prompt (KX-FP218)	-----	-----	NG
815	Sensor & VOX test	-----	-----	NG
841	Digital SP-Phone RX & TX check (KX-FP218)	-----	-----	NG
852	Print test pattern	-----	-----	NG
853	Top margin	1~9 mm	5	OK
861	Paper Size	1:A4 / 2:LETTER	A4	OK
874	DTMF ON time	06~20 x 10msec	10 x 10msec	OK
875	DTMF OFF time	06~20 x 10msec	10 x 10msec	OK
880	History list	1:Start	-----	NG
881	Journal 2	1:Start	-----	NG
882	Journal 3	1:Start	-----	NG
961	TEL/FAX pseudo ring back time	01~10 sec	07 sec	OK
962	TEL/FAX pseudo ring back time and bell time	05~30 sec	10 sec	OK
991	Remote Setup list	1:Start	-----	OK
994	Remote Journal list	1:Start	-----	OK
995	Remote Journal 2 list	1:Start	-----	OK
996	Remote Journal 3 list	1:Start	-----	OK
998	Remote History list	1:Start	-----	OK
999	Remote Service list	1:Start	-----	OK

OK means "can set".

NG means "can not set".

Note:

- *1 : Power is OFF/ON after changing this set value.
- Refer to **Service Function Table** (P.63) for descriptions of the individual codes.

Example:

If you want to set value in the "004 Print confirmation report", press the dial key number 1,2 or 3 corresponding to the Set Value you want to select. (1:ERROR / 2:ON / 3:OFF)

12.5. Troubleshooting Details

12.5.1. Outline

Troubleshooting is for recovering quality and reliability by determining the broken component and replacing, adjusting or cleaning it as required. First, determine the problem then decide the troubleshooting method. If you have difficulty finding the broken part, determine which board is broken. (For example: the Digital PCB, Analog PCB, etc.) The claim tag from a customer or dealer may use different expressions for the same problem, as they are not a technician or engineer. Using your experience, test the problem area corresponding to the claim. Also, returns from a customer or dealer often have a claim tag. For these cases as well, you need to determine the problem. Test the unit using the simple check list on **Simple Check List** (P.102). Difficult problems may be hard to determine, so repeated testing is necessary.

12.5.2. Starting Troubleshooting

Determine the symptom and the troubleshooting method.

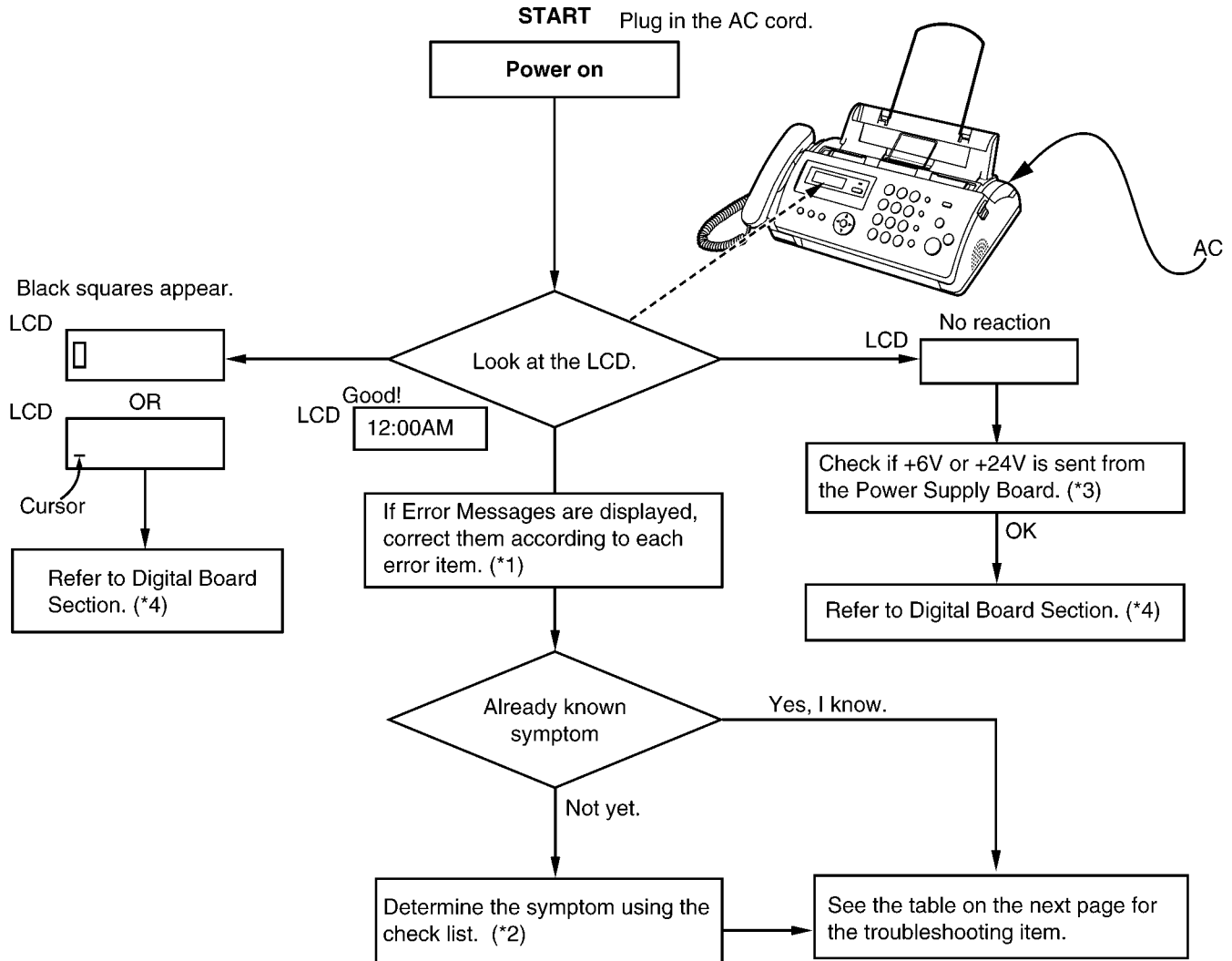

REFERENCE:

- (*1): **Error Messages-Display** (P.73)
- (*2): **Simple Check List** (P.102)
- (*3): **Power Supply Board Section** (P.128)
- (*4): **Digital Board Section** (P.116)

12.5.3. Troubleshooting Items Table

ITEM	SYMPTOM	REFERENCE
ADF (Auto Document Feeder)	The document does not feed.	See No Document Feed (P.103)
	Document jam	See Document Jam (P.104)
	Multiple feed	See Multiple Document Feed (P.105)
	Skew	See Document Skew (P.106)
Recording paper feed	The recording paper does not feed.	See The Recording Paper does not Feed (P.107)
	Paper jam	See Paper Jam (P.108)
	Multiple feed and skew	See Recording Paper Multiple Feed and Skew (P.109)
Printing	The sent fax data is skewed.	See The Sent Fax Data is Skewed (P.109)
	The received fax data is skewed.	See The Received Fax Data is Skewed (P.109)
	The received or copied data is expanded.	See Received or Copied Data is Expanded (P.110)
	A black page is copied.	See A Blank Page is Copied (P.111)
	A blank page is received.	See A Blank Page is Received (P.113)
	Black or white vertical line	See Black or White Vertical Line (P.113)
	Black or white lateral line on print out	See Black or White Lateral Line on Print Out (P.114)
	An abnormal image is printed	See An Abnormal Image is Printed (P.115)
Communication FAX, TEL (Analog board)	Cannot communicate by fax. An error code is displayed.	See Communication Section (P.88) and Journal Report (P.75)
	Cannot talk. The DTMF tone doesn't work. The handset / monitor doesn't work, etc.	See Analog Board Section (P.123)
Operation panel	Keys are not accepted.	See Operation Panel Section (P.131)
Sensor	If the electric circuit is the cause, the error message corresponding to the sensor will be displayed.	See Sensor Section (P.132)

12.5.3.1. Simple Check List

SERIAL NO.		DATE	
FUNCTION		JUDGEMENT	REFERENCE
FAX operation	Transmission	OK / NG	
	Receiving	OK / NG	
Copy operation		OK / NG	
Telephone operation	Handset transceiver / receiver	OK / NG	
	MONITOR	OK / NG	
	Ringer sound	OK / NG	
	Dial operation	OK / NG	
	Volume operation	OK / NG	
Operation Panel	Key check	OK / NG	Service code #561 (Refer to Test Mode (P.58).)
	LED check	OK / NG	Service code #557 (Refer to Test Mode (P.58).)
	LCD check	OK / NG	Service code #558 (Refer to Test Mode (P.58).)
Sensor	Sensor check	OK / NG	Service code #815 (Refer to Test Mode (P.58).)
Clock	Display changing	OK / NG	Is the time kept correctly? Check with another clock.
EXT-TAM	Handset transceiver/receiver	OK / NG	
	Remote control	OK / NG	

12.5.4. ADF (Auto Document Feed) Section

12.5.4.1. No Document Feed

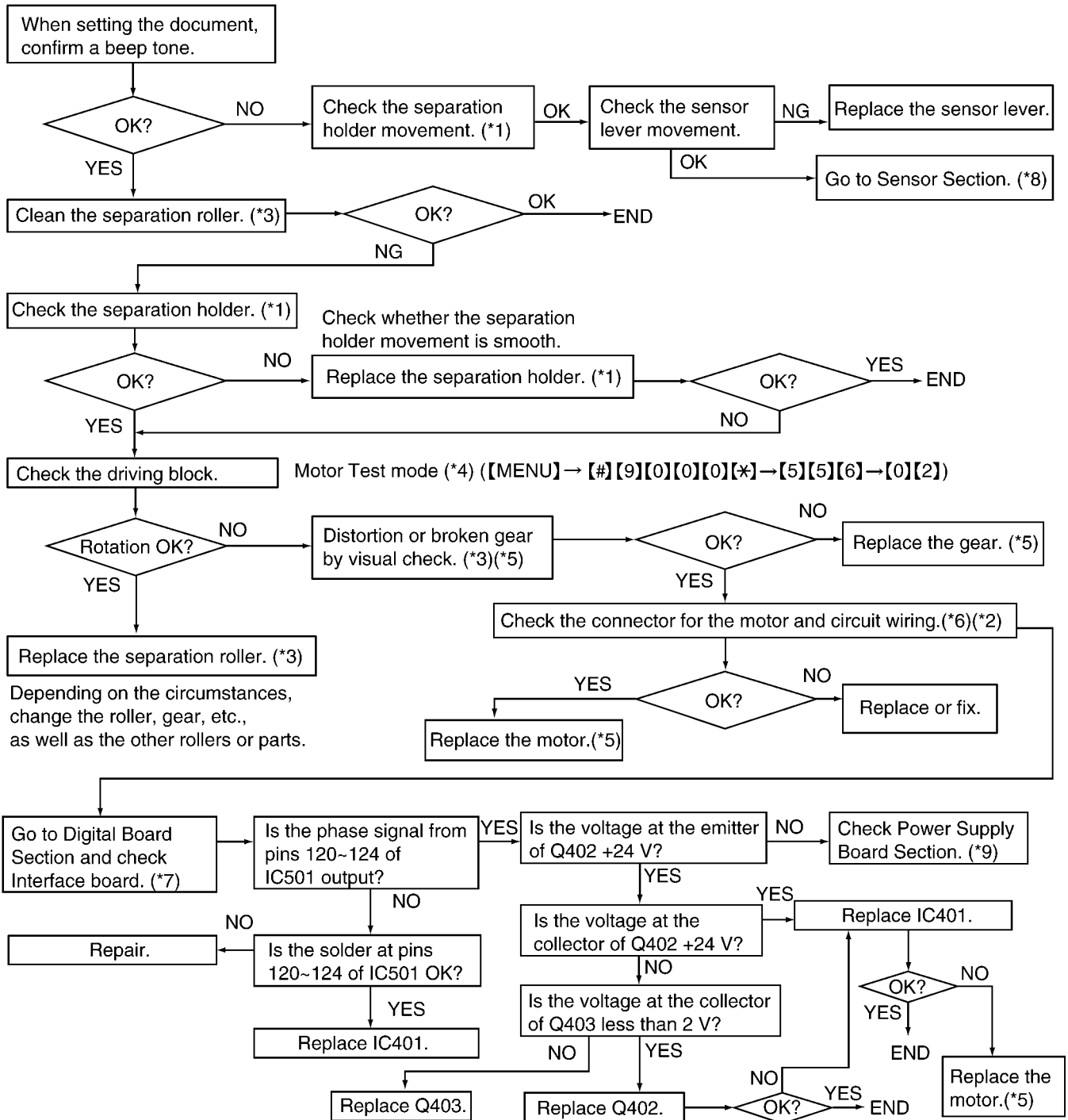

REFERENCE:

- (*1): How to Remove the Separation Holder and Exit Roller (P.157)
- (*2): Installation Position of the Lead Wires (P.158)
- (*3): How to Remove the Gear Block and Separation Roller (P.146)
- (*4): Test Mode (P.58)
- (*5): How to Remove the Gears, Motors and Arms of the Gear Block (P.147)
- (*6): Stepping Motor Drive Circuit (P.27)
- (*7): Digital Board Section (P.116)
- (*8): Sensor Section (P.132)
- (*9): Power Supply Board Section (P.128)

12.5.4.2. Document Jam

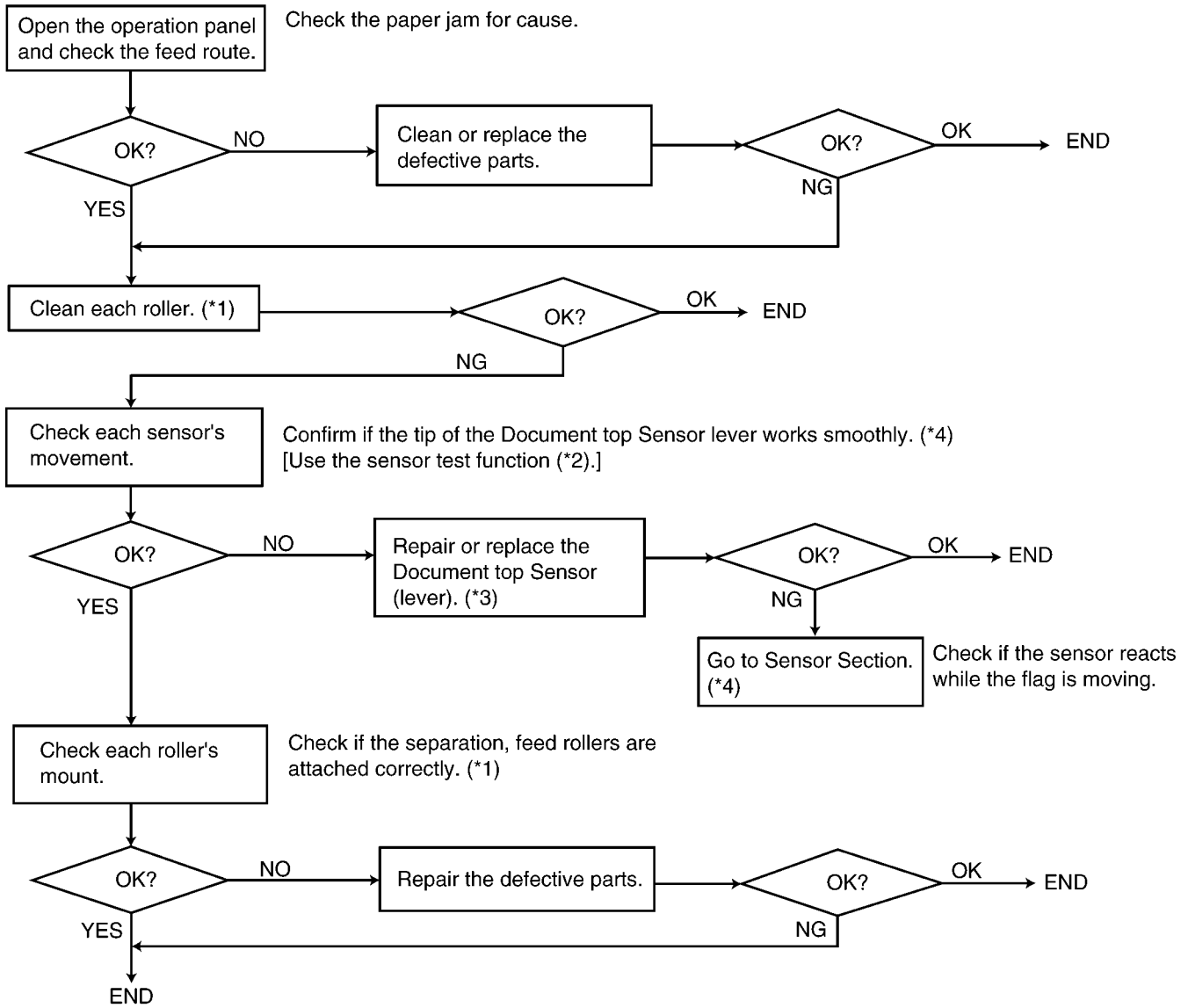

REFERENCE:

- (*1): Disassembly and Assembly Instructions (P.137)
- (*2): Test Mode (P.58)
- (*3): How to Remove the Separation Holder and Exit Roller (P.157)
- (*4): Sensor Section (P.132)

12.5.4.3. Multiple Document Feed

- When using thick paper etc., sometimes the document will not be fed. (*1)

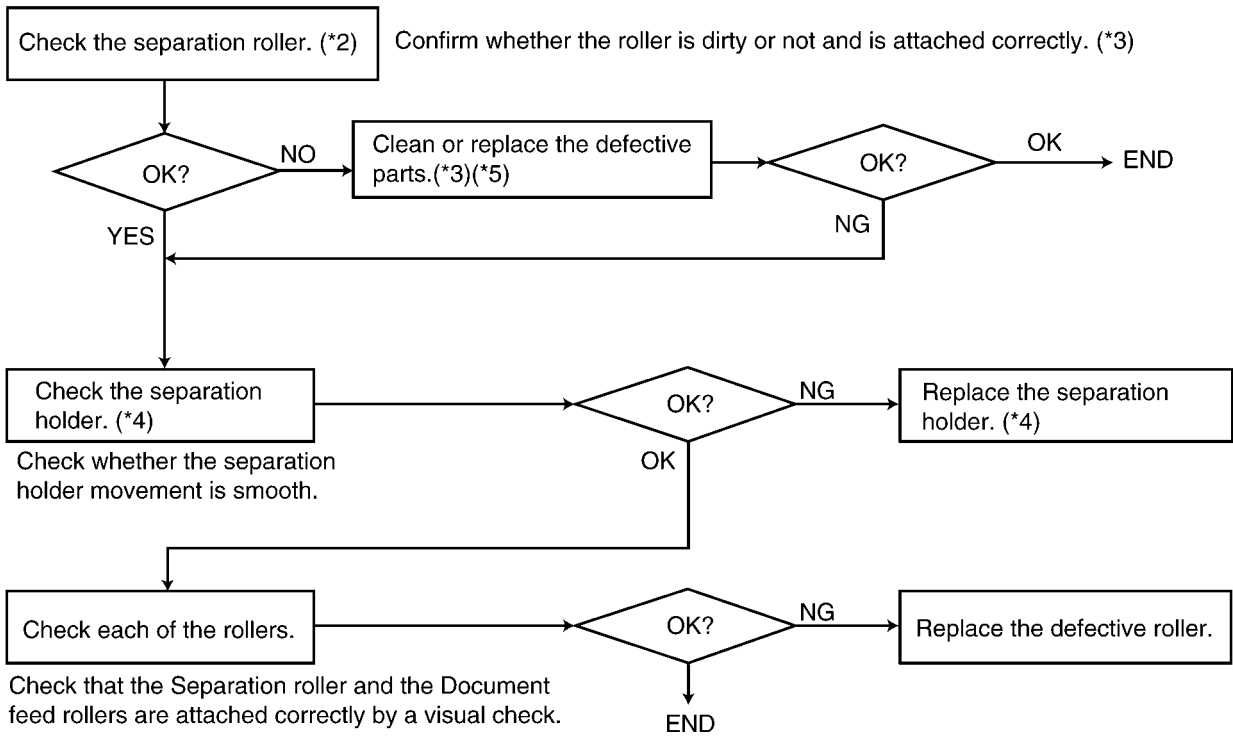

REFERENCE:

- (*1): **Installing the Recording Paper** (P.55)
- (*2): **How to Remove the Gear Block and Separation Roller** (P.146)
- (*3): **Disassembly and Assembly Instructions** (P.137)
- (*4): **How to Remove the Separation Holder and Exit Roller** (P.157)
- (*5): **Maintenace** (P.163)

Note:

When confirming if the characters are extended or distorted, or if the feed problem is occurred, use this test chart format. (Refer to **Test Chart** (P.182).)

12.5.4.4. Document Skew

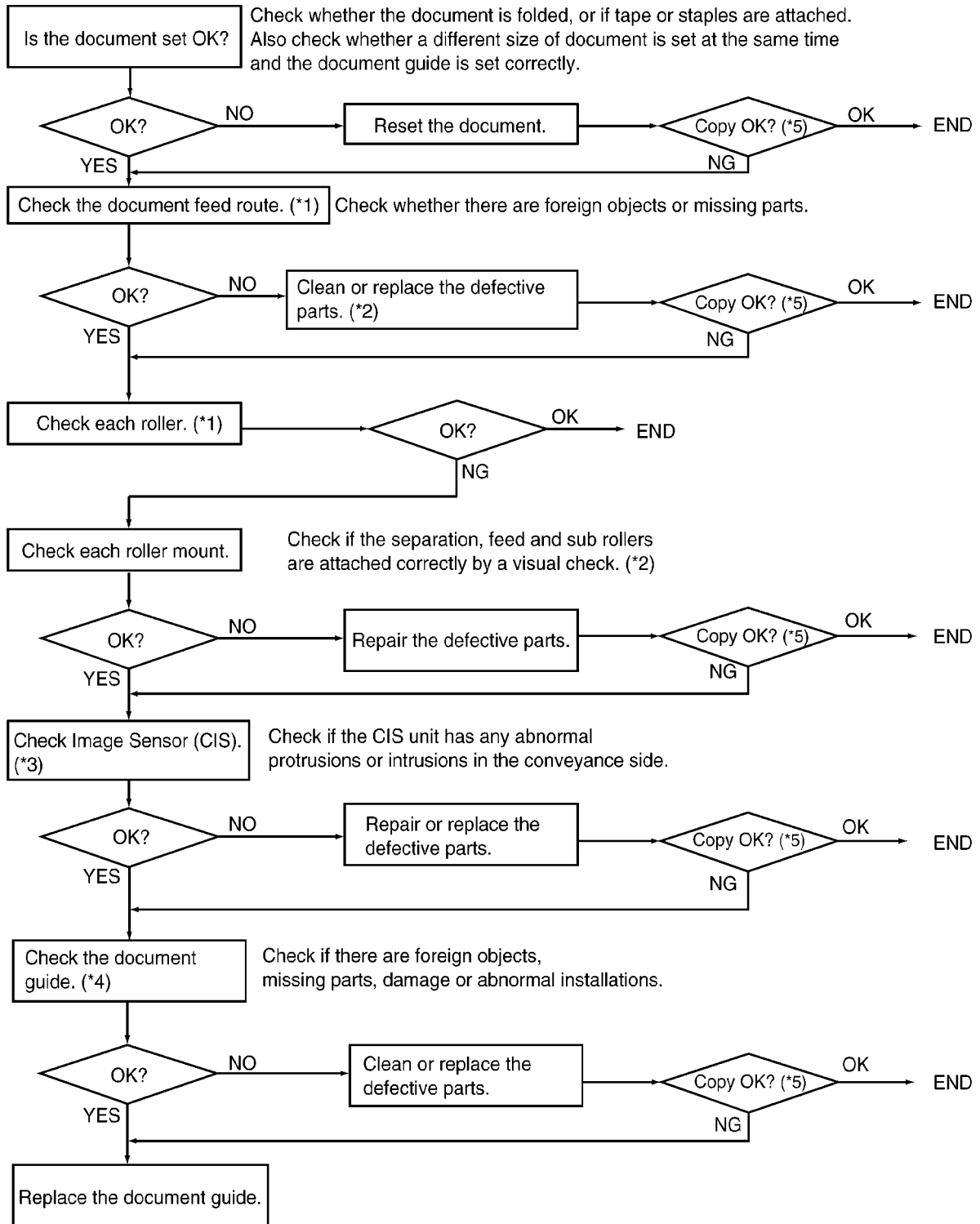

REFERENCE:

- (*1): **Maintenance Items and Component Locations** (P.163)
- (*2): **Disassembly and Assembly Instructions** (P.137)
- (*3): **How to Remove the Image Sensor (CIS)** (P.140)
- (*4): **Overview** (P.50)
- (*5): We recommend making a copy of the test chart in **Test Chart** (P.182) and using it.

12.5.4.5. The Recording Paper does not Feed

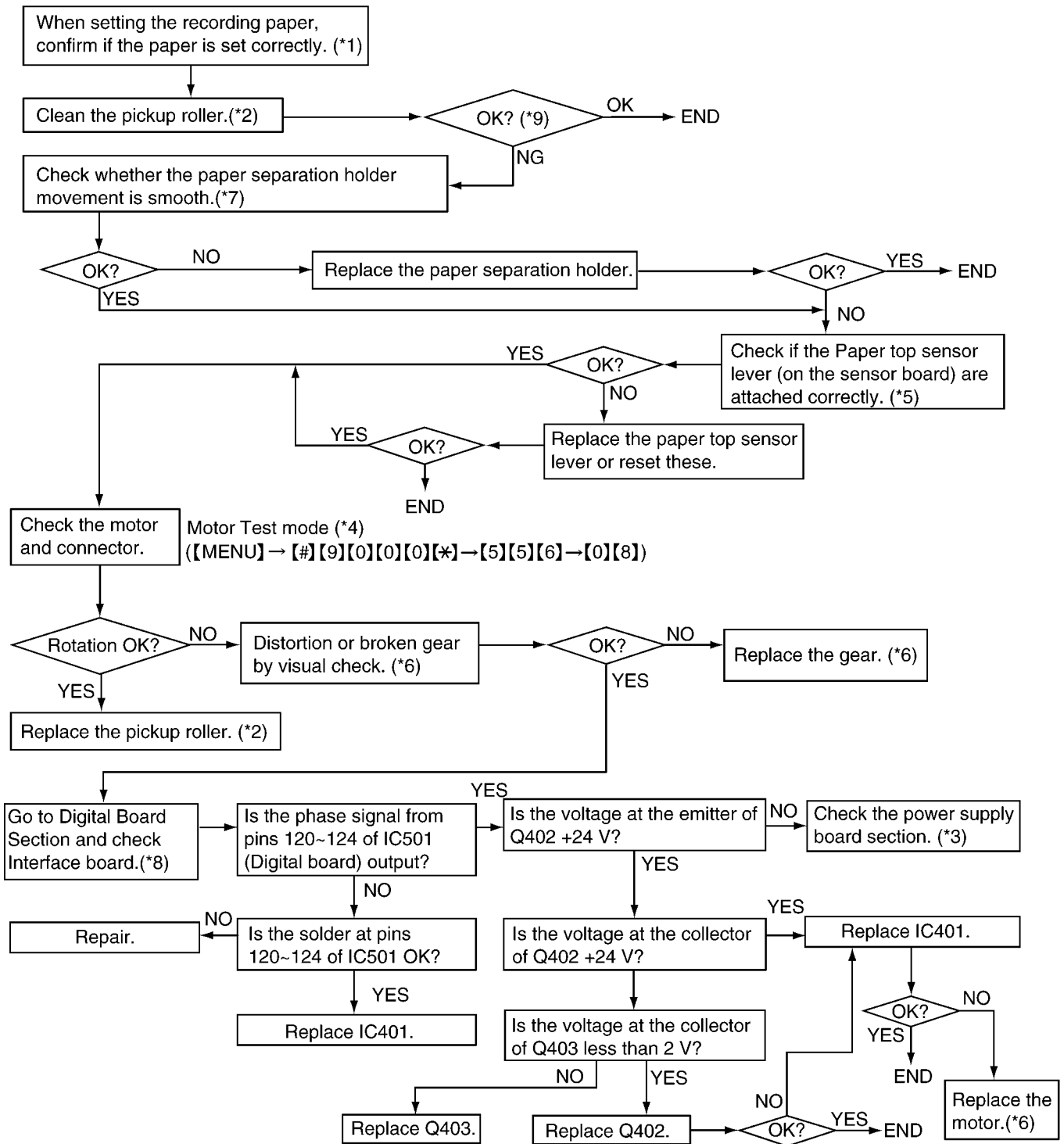

REFERENCE:

- (*1): Installing the Recording Paper (P.55)
- (*2): How to Remove the Pickup Roller (P.153)
- (*3): Power Supply Board Section (P.128)
- (*4): Test Mode (P.58)
- (*5): How to Remove the P.C. Boards and Speaker (P.144)
- (*6): How to Remove the Gears, Motors and Arms of the Gear Block (P.147)
- (*7): How to Remove the Platen Roller and Lock Lever (P.151)
- (*8): Digital Board Section (P.116)
- (*9): We recommend making a copy of the test chart in Test Chart (P.182) and using it.

12.5.4.6. Paper Jam

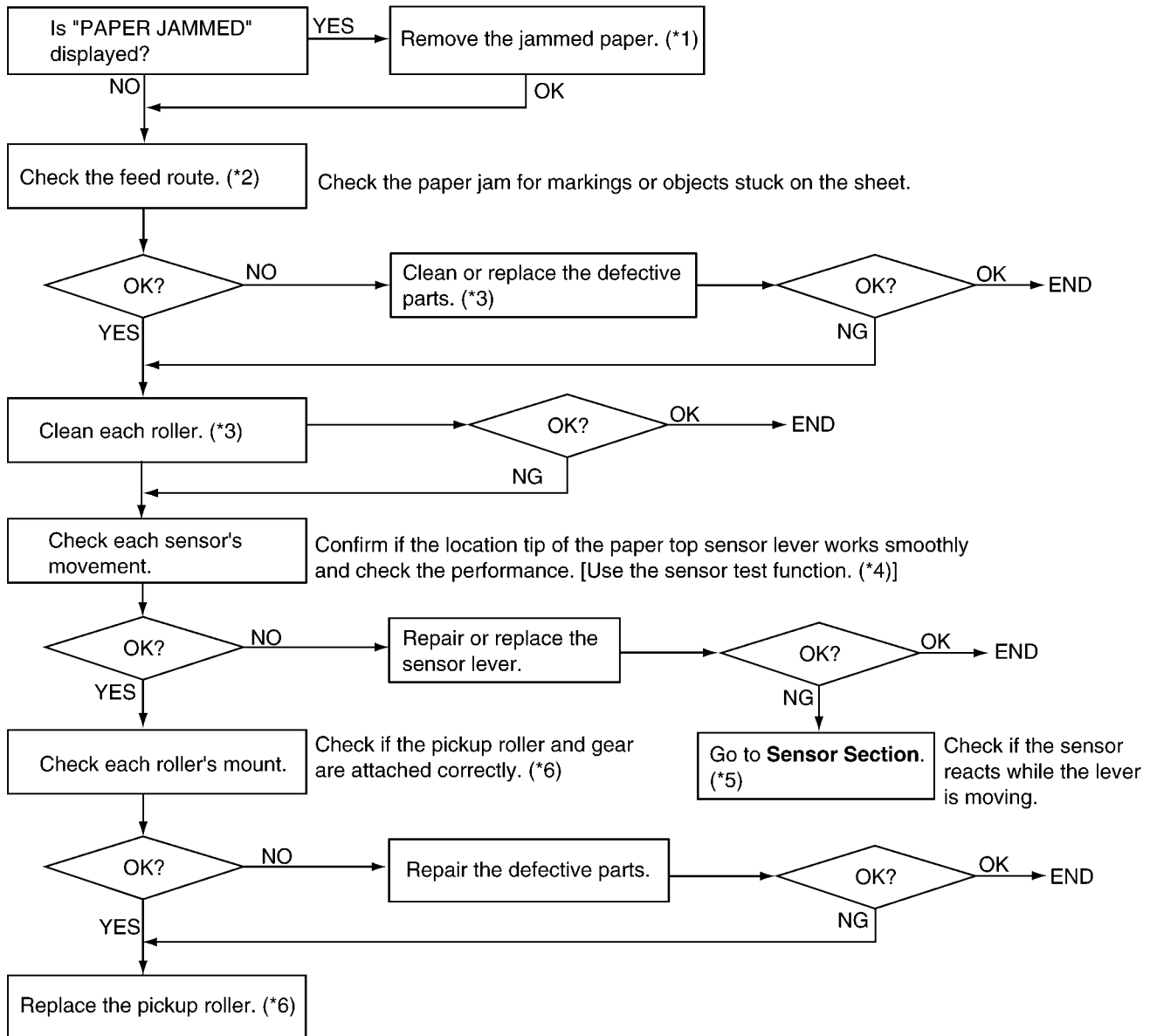

REFERENCE:

- (*1): Jams (P.172)
- (*2): Maintenance Items and Component Locations (P.163)
- (*3): Disassembly and Assembly Instructions (P.137)
- (*4): Test Mode (P.58)
- (*5): Sensors and Switches (P.29)
- (*6): How to Remove the Pickup Roller (P.153)

12.5.4.7. Recording Paper Multiple Feed and Skew

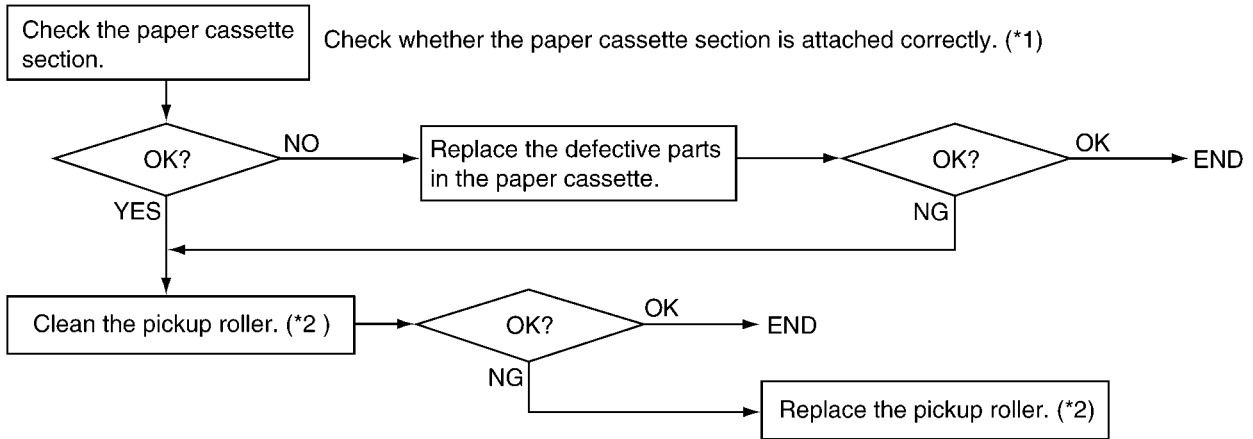

REFERENCE:

(*1): How to Remove the Platen Roller and Lock Lever (P.151)

(*2): How to Remove the Pickup Roller (P.153)

12.5.4.8. The Sent Fax Data is Skewed

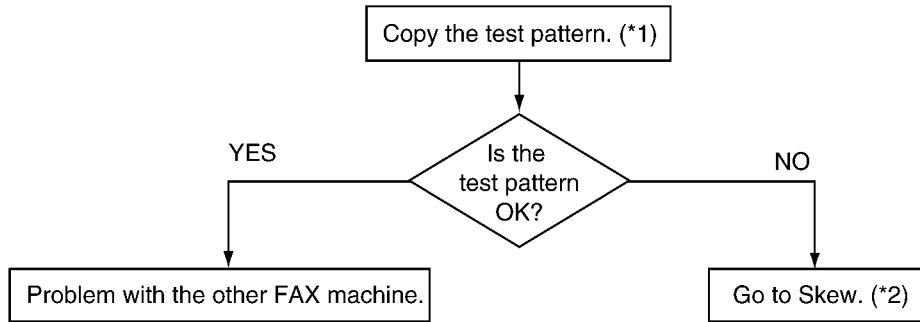

REFERENCE:

(*1): We recommend making a copy of the test chart in **Test Chart** (P.182) and using it.

(*2): **Document Skew** (P.106)

12.5.4.9. The Received Fax Data is Skewed

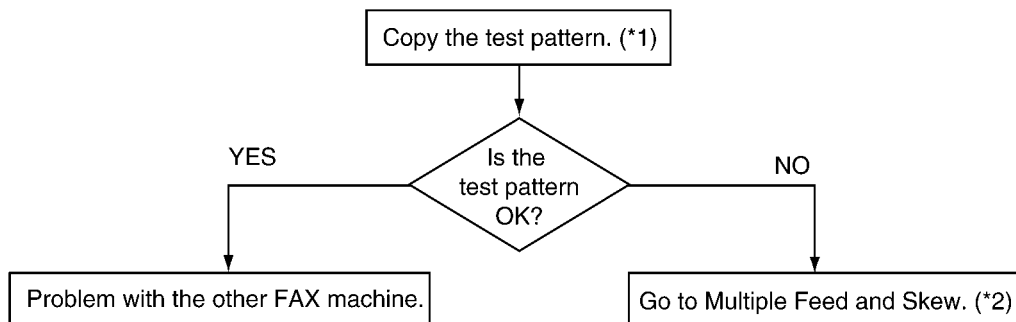

REFERENCE:

(*1): We recommend making a copy of the test chart in **Test Chart** (P.182) and using it.

(*2): **Recording Paper Multiple Feed and Skew** (P.109)

12.5.4.10. Received or Copied Data is Expanded

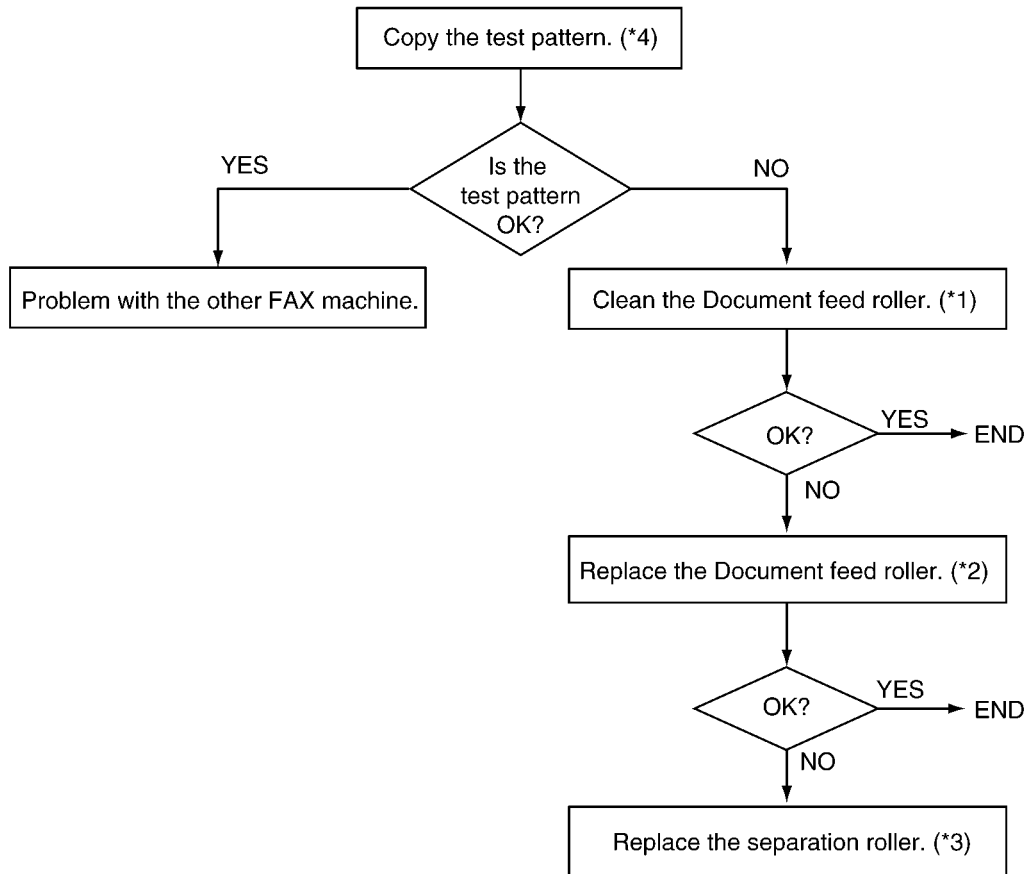

REFERENCE:

- (*1): Document feeder/recording paper feeder/scanner glass cleaning (P.174)
- (*2): Disassembly and Assembly Instructions (P.137)
- (*3): How to Remove the Separation Holder and Exit Roller (P.157)
- (*4): We recommend making a copy of the test chart in **Test Chart** (P.182) and using it.

12.5.4.11. A Blank Page is Copied

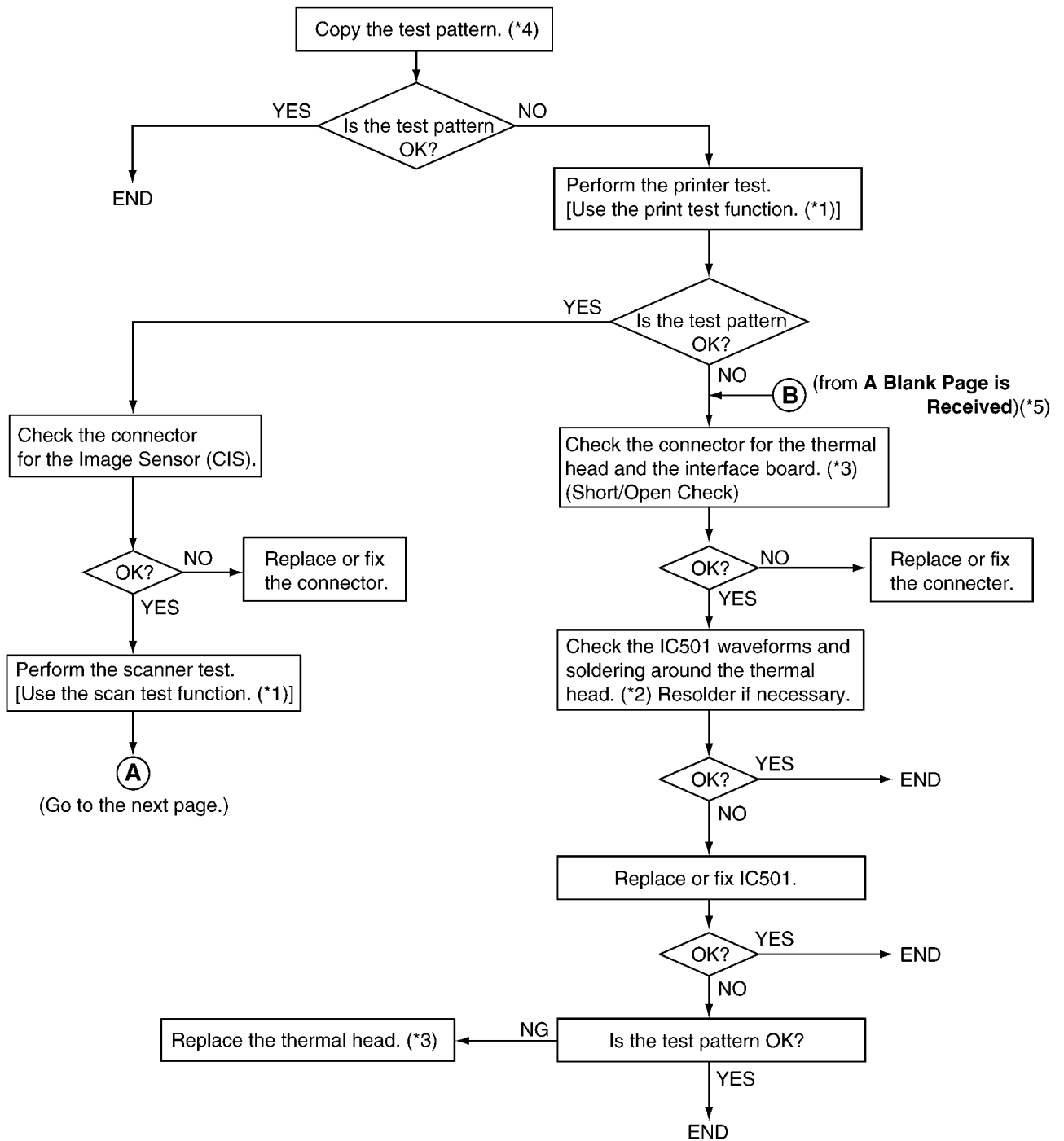

REFERENCE:

- (*1): **Test Mode** (P.58)
- (*2): **Thermal Head** (P.24)
- (*3): **How to Remove the Thermal Head** (P.141)
- (*4): We recommend making a copy of the test chart in **Test Chart** (P.182) and using it.
- (*5): **A Blank Page is Received** (P.113)

(From the previous)

A

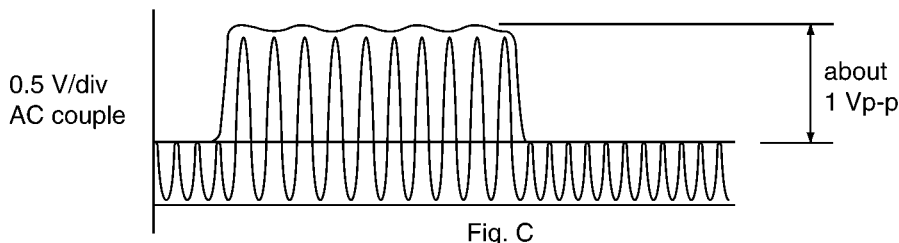
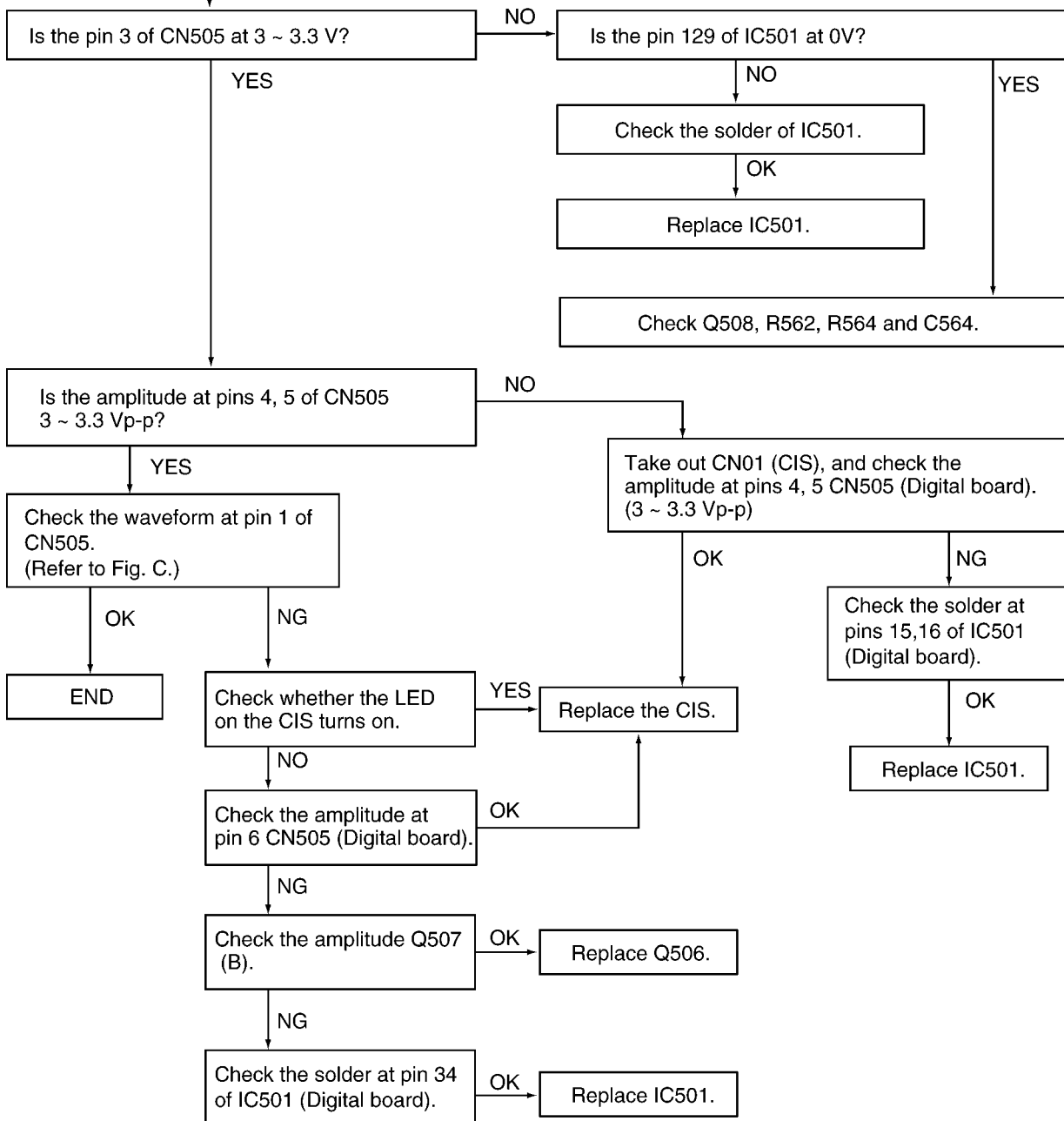

12.5.4.12. A Blank Page is Received

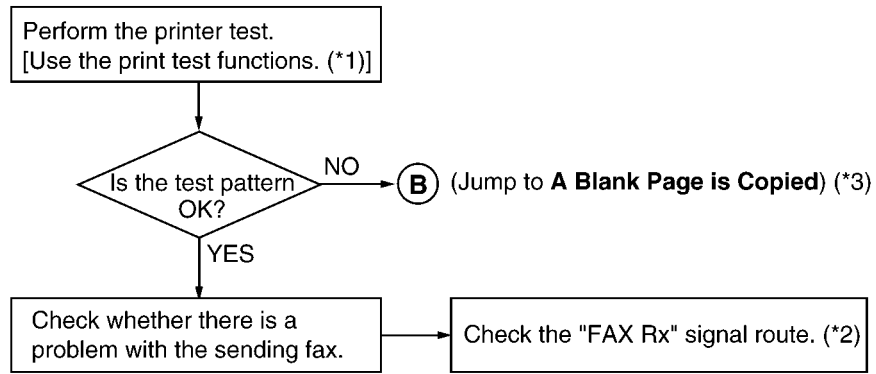

REFERENCE:

- (*1): **Test Mode** (P.58)
- (*2): **Check Sheet for Signal Route** (P.123)
- (*3): **A Blank Page is Copied** (P.111)

12.5.4.13. Black or White Vertical Line

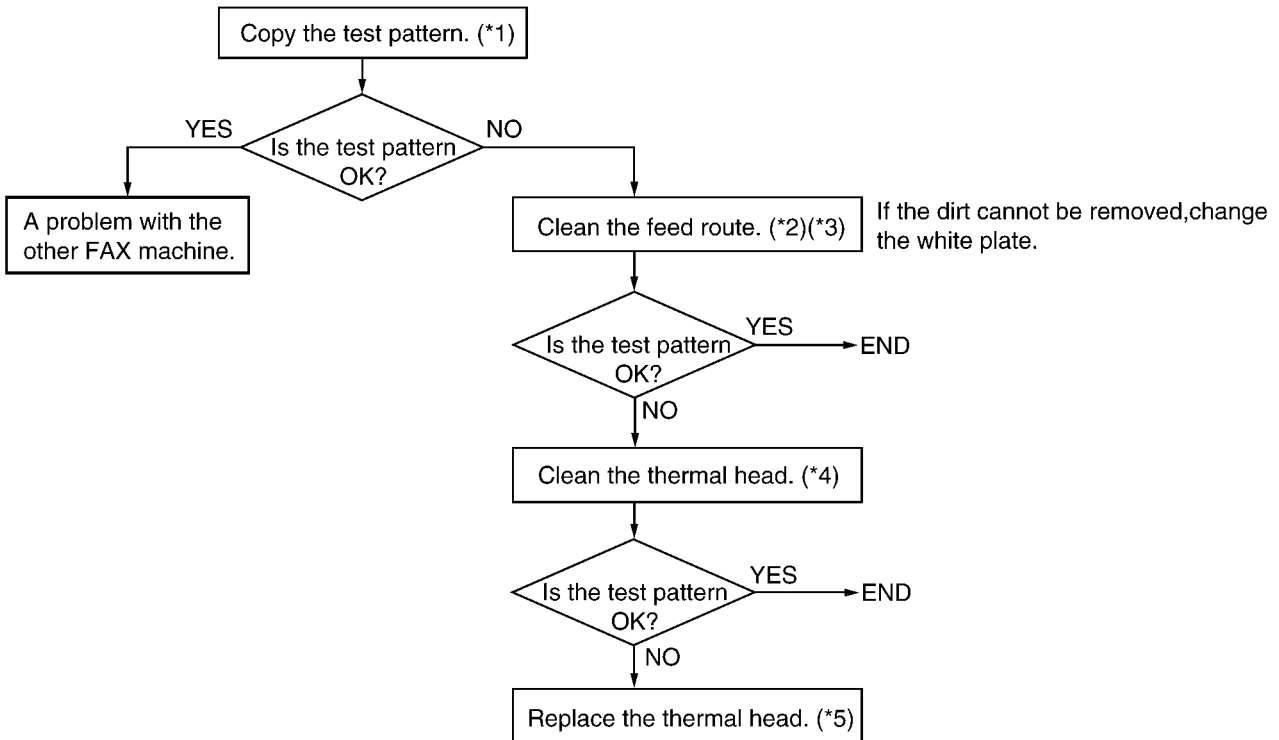

REFERENCE:

- (*1): We recommend making a copy of the test chart in **Test Chart** (P.182) and using it.
- (*2): **Maintenance Items and Component Locations** (P.163)
- (*3): **Document feeder/recording paper feeder/scanner glass cleaning** (P.174)
- (*4): **Thermal Head Cleaning** (P.175)
- (*5): **How to Remove the Thermal Head** (P.141)

12.5.4.14. Black or White Lateral Line on Print Out

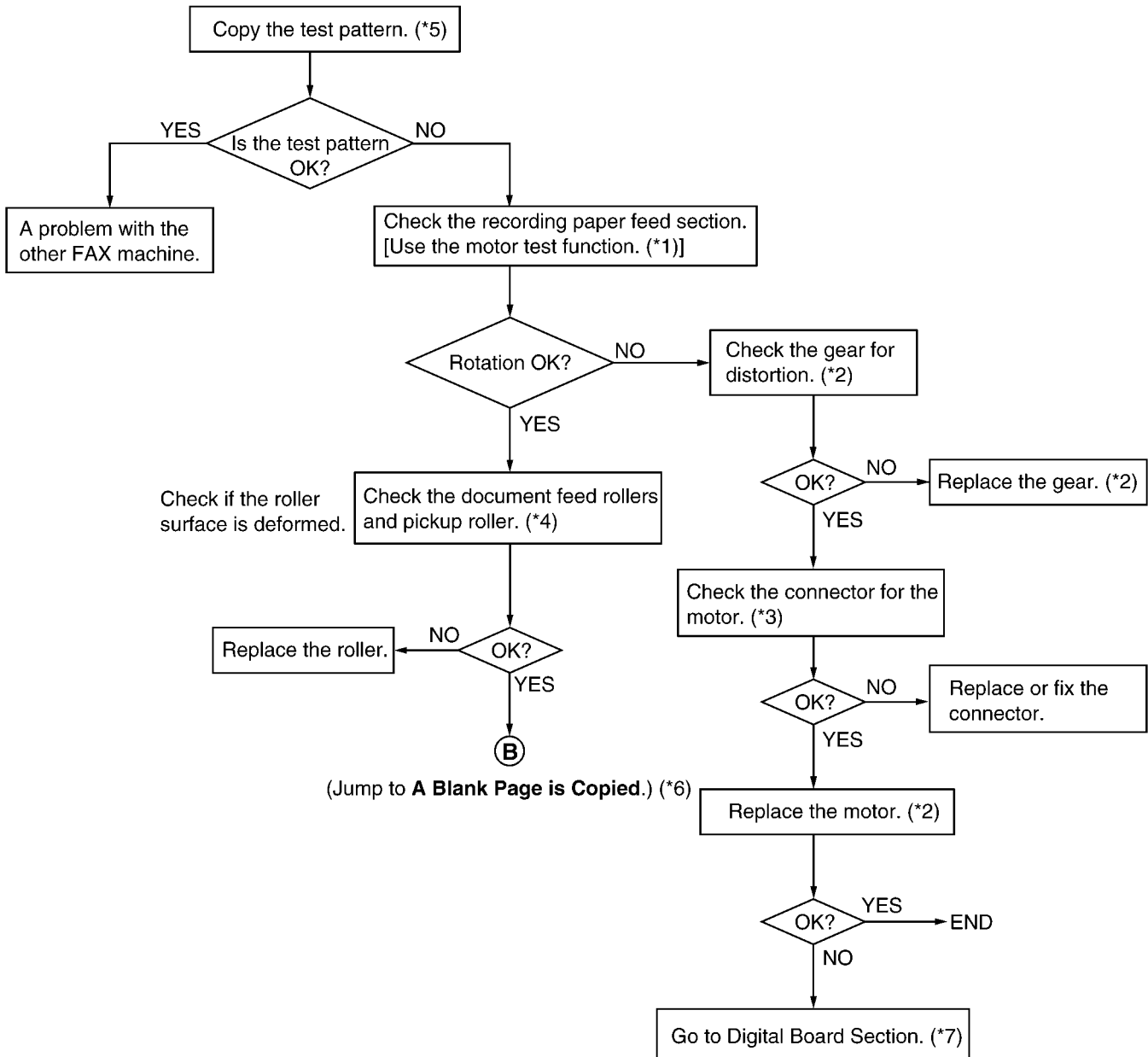

REFERENCE:

- (*1): **Test Mode** (P.58)
- (*2): **How to Remove the Gears, Motors and Arms of the Gear Block** (P.147)
- (*3): **Installation Position of the Lead Wires** (P.158)
- (*4): **Disassembly and Assembly Instructions** (P.137)
- (*5): We recommend making a copy of the test chart in **Test Chart** (P.182) and using it..
- (*6): **A Blank Page is Copied** (P.111)
- (*7): **Digital Board Section** (P.116)

12.5.4.15. An Abnormal Image is Printed

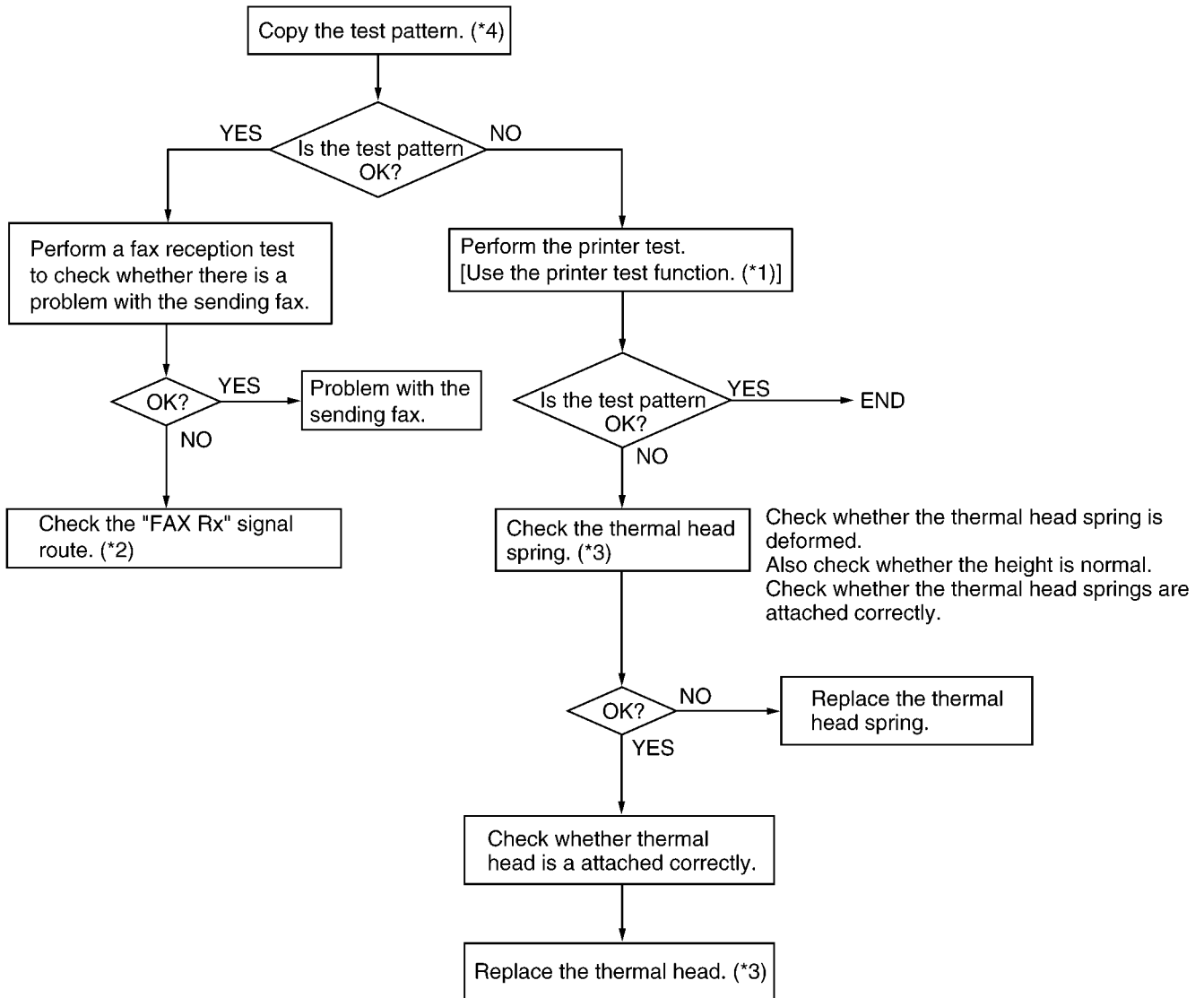

REFERENCE:

(*1): **Test Mode** (P.58)

(*2): **Check Sheet for Signal Route** (P.123)

(*3): **How to Remove the Thermal Head** (P.141)

(*4): We recommend making a copy of the test chart in **Test Chart** (P.182) and using it.

12.5.5. Digital Board Section

When the unit fails to boot up the system, take the troubleshooting procedures very carefully. It may have a serious problem.

The symptom: No response when the power is turned on. (No LCD display, and keys are not accepted.)

The first step is to check the power source. If there is no problem with the power supply unit, the problem may lie in the digital unit (main board).

As there are many potential causes in this case (ASIC, DRAM, etc.), it may be difficult to specify what you should check first. If a mistake is made in the order of checks, a normal part may be determined faulty, wasting both time and money.

Although the tendency is to regard the problem as a serious one (IC malfunction, etc.), usually most cases are caused by solder faults (poor contact due to a tunnel in the solder, signal short circuit due to solder waste).

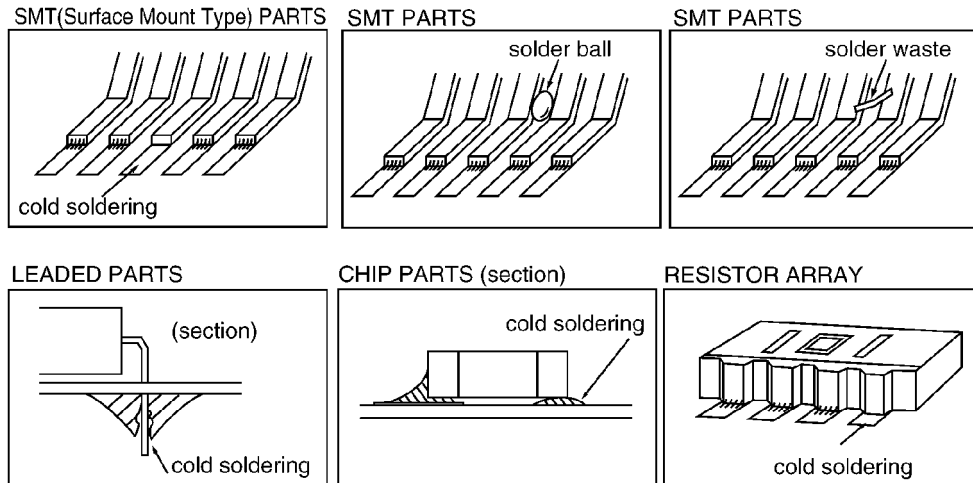

Note:

1. Electrical continuity may have existed at the factory check, but a faulty contact occurred as a result of vibration, etc., during transport.
2. Solder waste remaining on the board may get caught under the IC during transport, causing a short circuit.

Before we begin mass production, several hundred trial units are produced at the plant, various tests are applied and any malfunctions are analyzed. (In past experiences, digital IC (especially DRAM and FLASH ROM) malfunctions are extremely rare after installation in the product.)

This may be repaired by replacing the IC, (DRAM etc.). However, the real cause may not have been an IC malfunction but a soldering fault instead.

Soldering faults difficult to detect with the naked eye are common, particularly for ASIC and RA (Resistor Array). But if you have an oscilloscope, you can easily determine the problem site or IC malfunction by checking the main signal lines.

Even if you don't have such a measuring instrument, by checking each main signal line and resoldering it, in many cases the problem will be resolved.

An explanation of the main signals (for booting up the unit) is presented below.

Don't replace ICs or stop repairing until checking the signal lines.

An IC malfunction rarely occurs. (By understanding the necessary signals for booting up the unit, the "Not Boot up" display is not a serious problem.)

What are the main signals for booting up the unit?

Please refer to **Digital Block Diagram** (P.117).

The ASIC (IC501) controls all the other digital ICs. When the power is turned on, the ASIC retrieves the operation code stored in the FLASH ROM (IC506), then follows the instructions for controlling each IC. All ICs have some inner registers that are assigned to a certain address.

It is the address bus by which the ASIC designates the location inside each IC. And the data bus reads or writes the data in order to transmit the instructions from the ASIC to the ICs.

These signal lines are all controlled by voltages of 3.3V (H) or 0V (L).

12.5.5.1. Digital Block Diagram

You also need to check the signal lines listed here [List 1] when the unit fails to boot up the system. Those signal lines should remain normal. Other signal lines are not directly related to that failure even if they have faults or troubles.

[List 1]

①	D0~D7	(Data Bus)
②	A0~A15	(Address Bus)
③	\overline{RD}	(Read Signal)
	ROMCS	(ROM Select Signal)
	WR	(Write Signal)
④	RBA0~RBA5	(Bank Address Signal)
⑤	\overline{RAS}	(DRAM Row Address Strobe Signal)
	\overline{CAS}	(DRAM Column Address Strobe Signal)
⑥	\overline{MDMCS}	(Modem Select Signal)

As long as these signals remain normal, once the power is turned on, each IC can repeatedly output 3.3V (H) and 0V (L). The following shows NG and normal wave patterns.

NG Wave pattern (Refer to NG EXAMPLE)

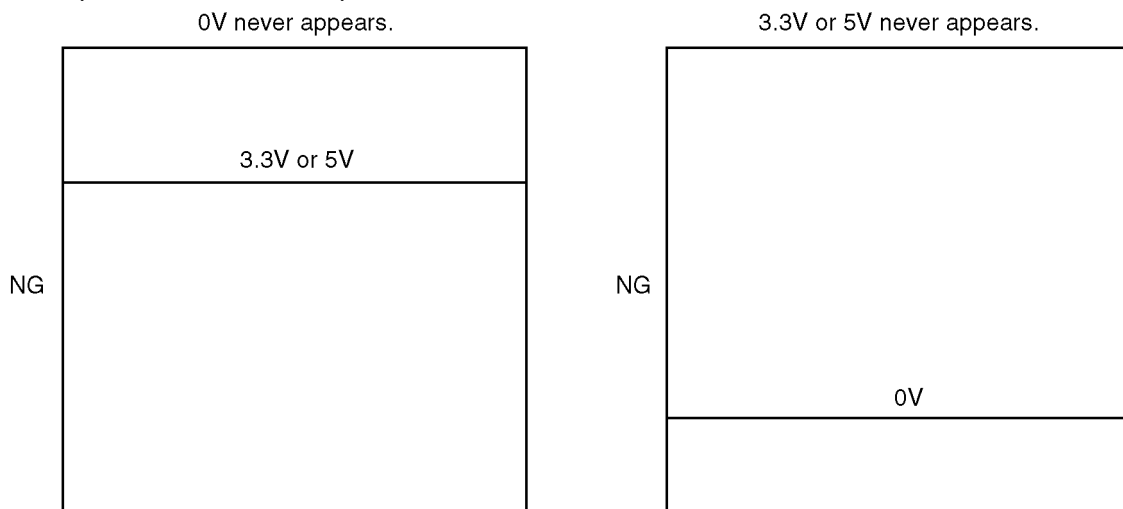

Normal Wave Patterns

① D0~D7 200ns/div, 1V/div

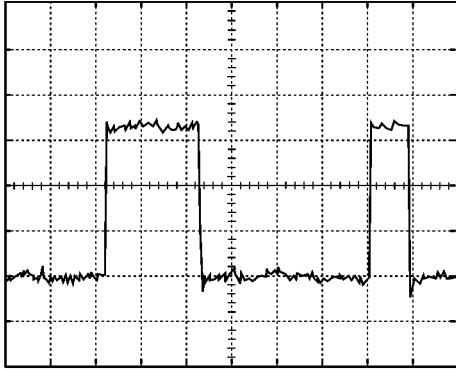

② A0~A5 200ns/div, 1V/div

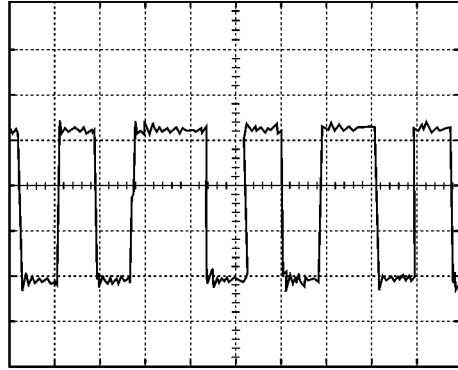
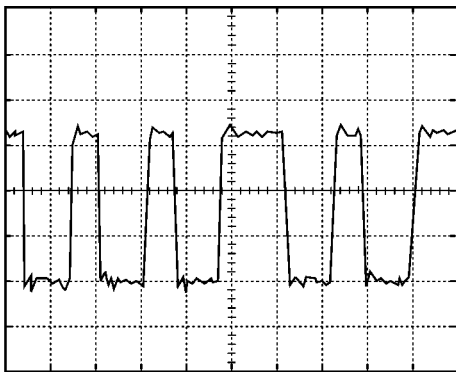
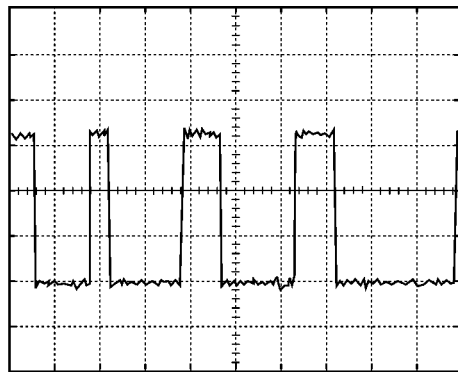
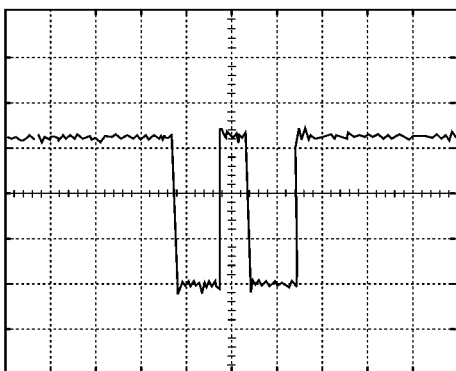
③ \overline{RD} 100ns/div, 1V/div④ \overline{ROMCS} 400ns/div, 1V/div⑤ \overline{RAS} , \overline{CAS} 100ns/div, 1V/div**Remarks:**

When you use an oscilloscope to judge whether a signal to be tested is normal or NG, perform the signal check in exactly the same order as in [List 1]. (If the ASIC fails to access the FLASH ROM, the ASIC cannot access DRAM normally.)

The digital circuit actually operates according to the timing combinations of these signals. If the timing of these signals is even slightly delayed, the circuit will not work. Nor will it if the IC is defective and the output voltage level is not normal although the timing of these signals is accurate enough to meet the specifications. (Make sure that your oscilloscope is calibrated before starting a test.)

Therefore, it is imperative to confirm whether each IC outputs the signal at the correct level. (See the **I/O Pin No. Diagram**.) The signal level should be constantly output at between 3.3V (H) and 0V (L) as described earlier.

Note:

Simply check the output level and make sure if the IC repeatedly outputs the signal at between 3.3V (H) and 0V (L).

I/O and Pin No. Diagram

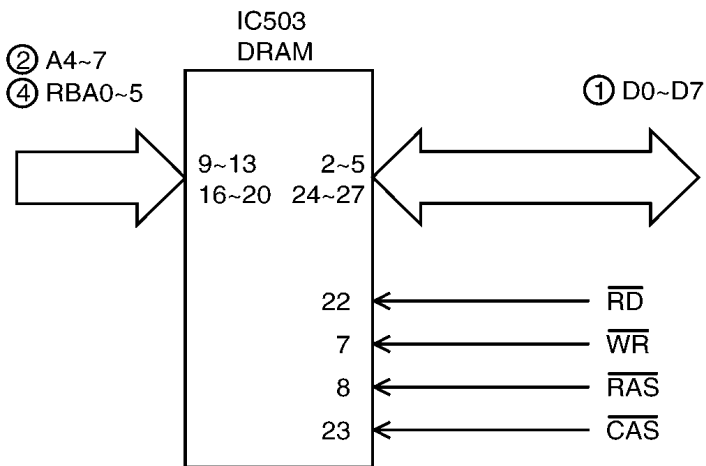
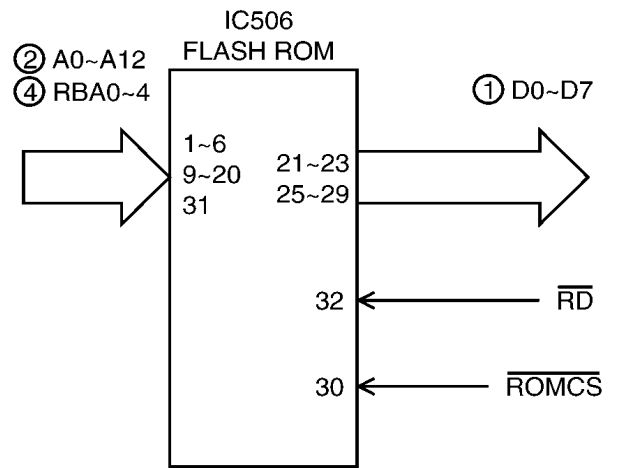
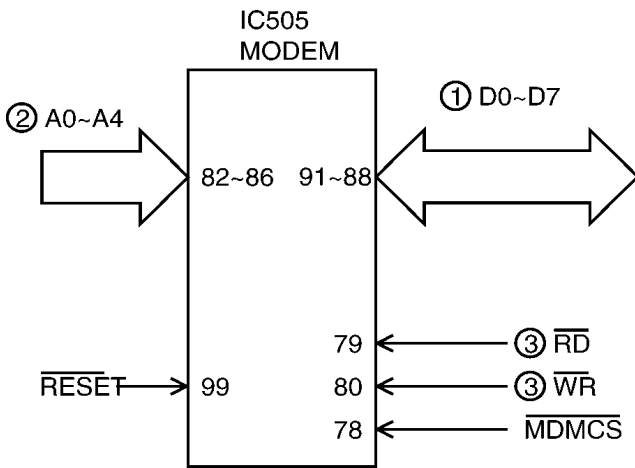
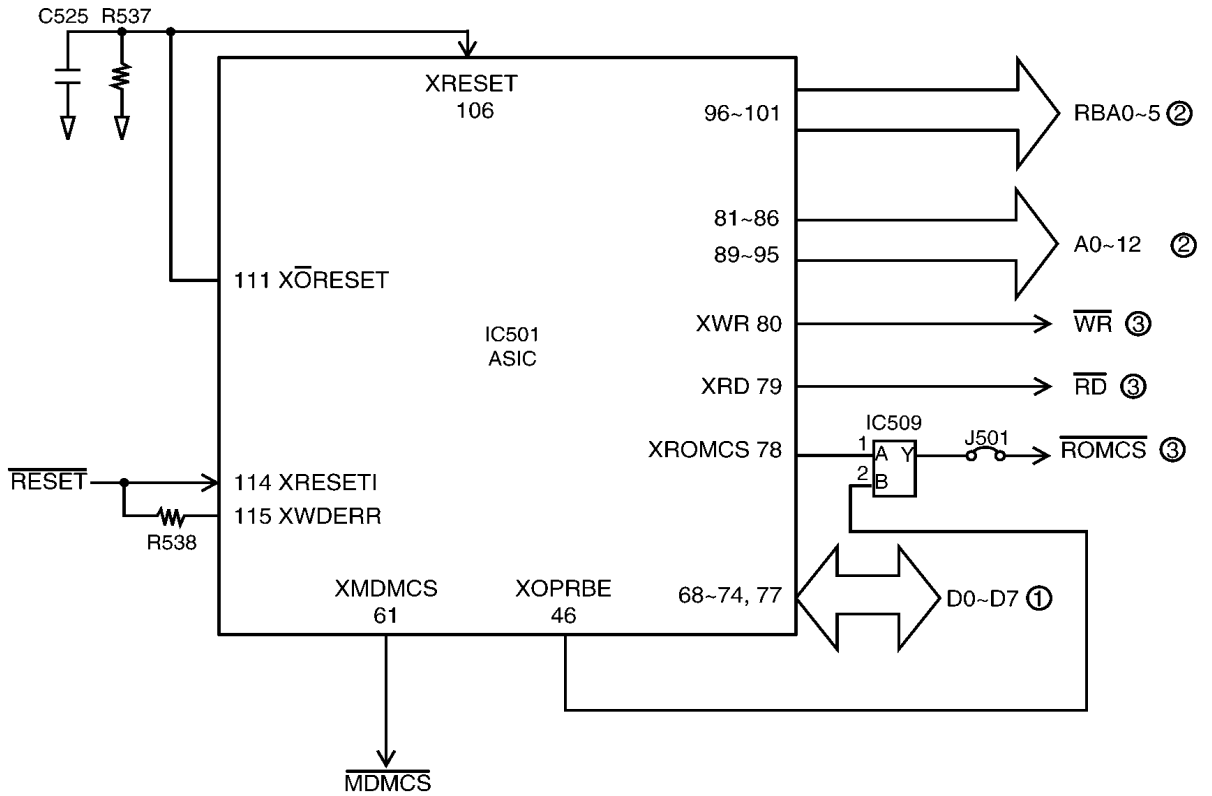

After the power is turned on, the ASIC initializes and checks each IC.
 The ROM, DRAM, and modem are checked.
 If initialization fails for the ICs, the system will not boot up.
 In this case, please find the cause as follows.

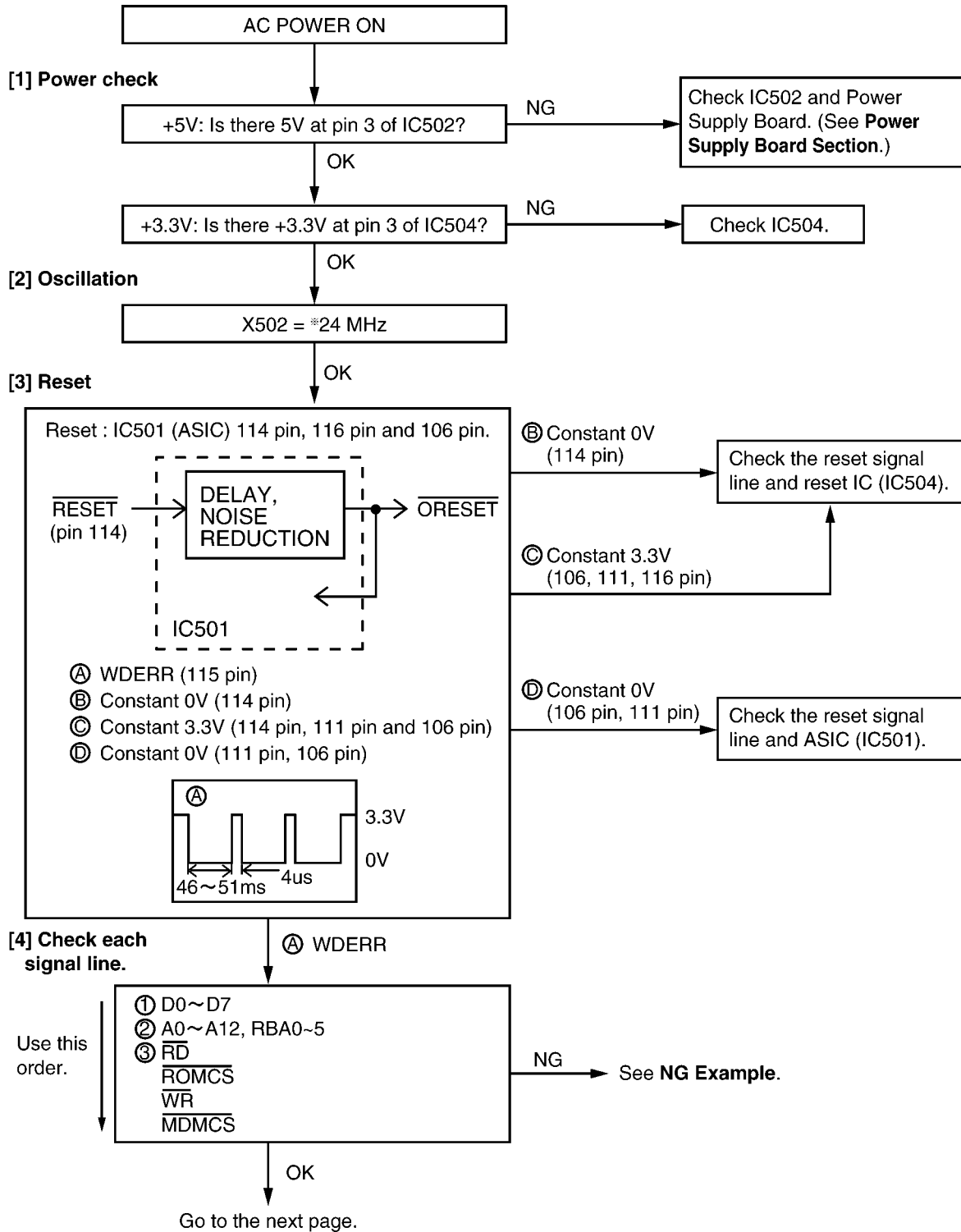

REFERENCE:

NG Example (P.122)

Power Supply Board Section (P.128)

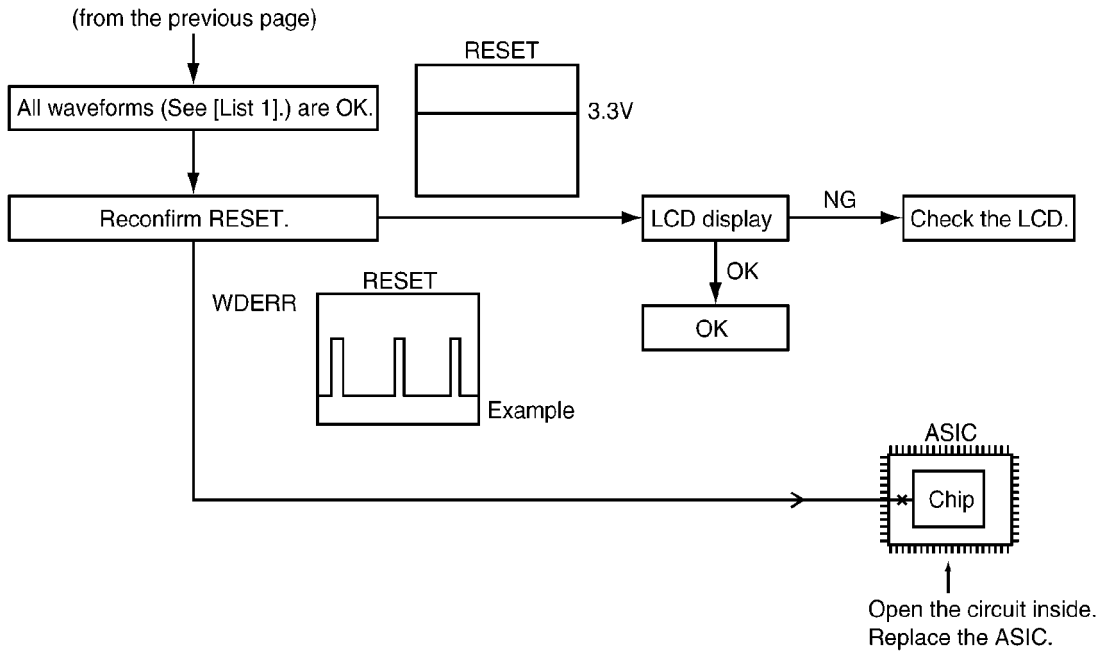

Other NG example while the power is ON and the LCD displays the following.

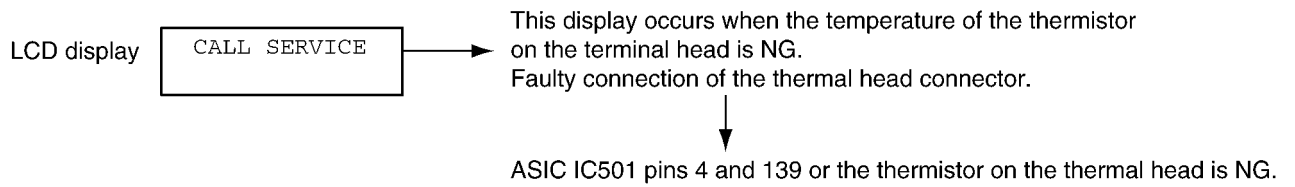

12.5.5.2. NG Example

Short circuit from the adjacent signal wires.
Check for a short circuit in the IC leads and the signal wire at the through hole.

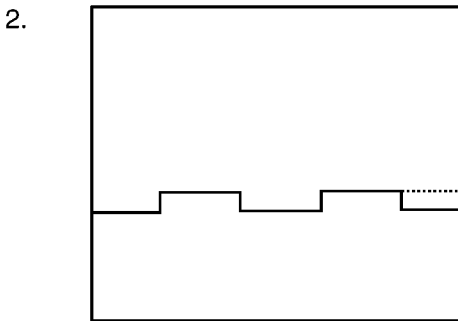
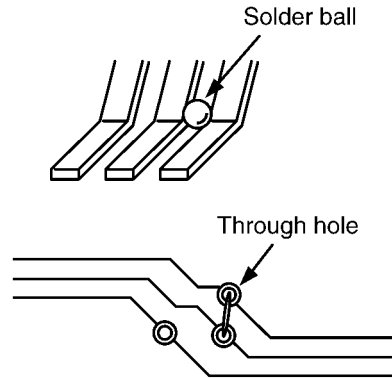
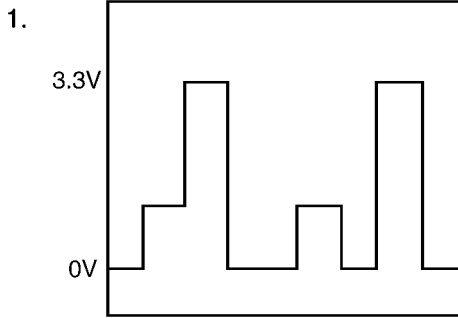

Short between the signal line and GND.

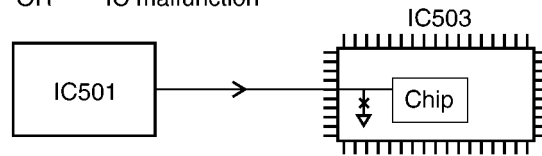
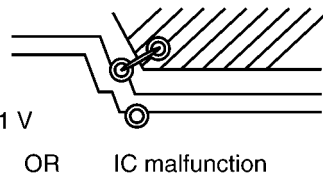

12.5.6. Analog Board Section

This chapter provides the testing procedures required for the analog parts. A signal route to be tested is determined depending upon purposes. For example, the handset TX route begins at the handset microphone and the signal is output to the telephone line. The signal mainly flowing on this route is analog. You can trace the signal with an oscilloscope. The signal flow on each route is shown in the Check Sheet here. If you find a specific problem in the unit, for example if you cannot communicate with the SP-PHONE, trace that signal route locally with the following Check Sheet and locate the faulty point.

12.5.6.1. Check Sheet for Signal Route

(SYMPTOM) ITEMS TO CHECK	IN → signal → ROUTE → OUT
MONITOR [FP207]	TEL LINE → T101 → C110 → R109 → IC102(2-1) → CN101(7) → {CN507(7) → IC508(3-4) → C574 → R572 → Q509(B-C) → C561 → IC501(32-31) → C613 → R609 → IC511(6-7) → C588 → R589 → IC510(4-5,8) → CN507(1,2)} → Speaker
HANDSET Tx	HSMIC → {CN102(1) → C142 → R151 → IC102(6) → IC102(7) → CN101(5) → {CN507(5) → R613 → C623 → R614 → C594 → R588 → IC511(2-1) → CN507(6)} → CN101(6) → C117 → R120 → R119 → T101 → TEL LINE CN102(2) → C139 → R152 → IC102(5)}
HANDSET Rx	TEL LINE → T101 → C110 → R109 → IC102(2-1) → CN101(7) → {CN507(7) → J503 → IC508(3-4) → C574 → R572 → Q509(B-C) → C561 → IC501(32-31) → C613 → R609 → IC511(6-7) → R591 → C589 → IC508(10-11) → CN507(4)} → CN101(4) → R143 → Q109(B-E) → C145 → CN102(5) → HANDSET Speaker
DTMF for Handset Speaker [FP207]	{IC505(58) → C584} → R580 → Q509(B-C) → C561 → IC501(32-31) → C613 → R609 → IC511(6-9) → R591 → C589 → IC508(10-11) → CN507(4)} → CN101(4) → R143 → Q109(B-E) → C145 → CN102(5) → HANDSET Speaker For FP218, { } is changed {IC505(42) → C581}
DTMF for Speaker [FP207]	{IC505(58) → C584} → R580 → Q509(B-C) → C561 → IC501(32-31) → C613 → R609 → IC511(6-7) → C588 → R589 → IC510(4-5,8) → CN507(1,2)} → Speaker
FAX Tx/ DTMF for TEL LINE	{IC505(56) → IC508(8-9) → C590 → R587 → IC511(2-1) → CN507(6)} → CN101(6) → C117 → R120 → R119 → T101 → TEL LINE
FAX Rx/CNG/DTMF Detection (OFF-HOOK)	TEL LINE → T101 → C110 → R109 → IC101(2-1) → CN101(7) → {CN507(7) → J503 → C638 → R627 → R623 → C630 → IC505(47)}
Ringing/BEEP/ Alarm/Key Tones	{IC501(29) → R575 → Q510(E-C) → C578 → R574 → Q509(B-C) → C561 → IC501(32-31) → C613 → R609 → IC511(6-7) → C588 → R589 → IC510(4-5,8) → CN507(1,2)} → Speaker
Caller ID/FAX Activate (ON-HOOK)	TEL LINE → C138 → R138 → C128 → T101 → C110 → R109 → IC101(2-1) → CN101(7) → {CN507(7) → C637 → R624 → C627 → IC505(50)}
SP-Phone TX [FP218]	MIC → {CN509(1) → C651 → R514 → Q515(B-C) → C633 → R619 → C632 → IC505(35-56) → R618 → IC508(8-9) → C590 → R587 → IC511(2-1) → CN507(6)} → CN101(6) → C117 → R120 → R119 → T101 → TEL LINE
SP-Phone RX [FP218]	TEL LINE → T101 → C110 → R109 → IC102(2-1) → CN101(7) → {CN507(7) → C638 → R627 → C630 → IC505(47-42) → C581 → R580 → Q509(B-C) → C561 → IC501(32-31) → C613 → R609 → IC511(6-7) → C588 → R589 → IC510(4-5,8) → CN507(1,2)} → Speaker

Note:

{ }: Inside the Digital Board

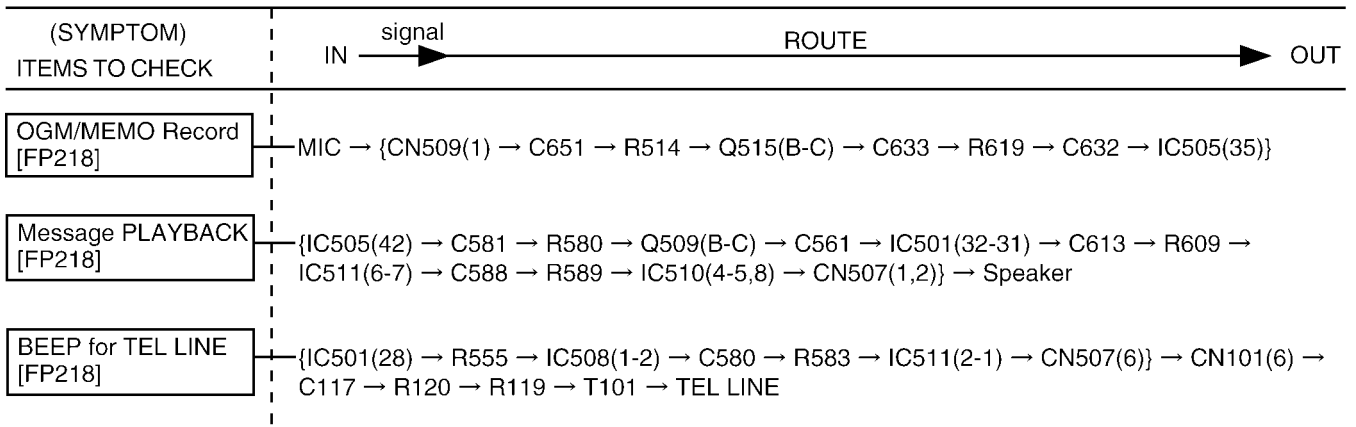

Note:

{ }: Inside the Digital Board

12.5.6.2. Defective ITS (Integrated Telephone System) Section

1. No handset transmission / reception and no monitor reception

Perform a signal test in the **ITS or the NCU section** and locate a defective point (where the signal disappears) on each route between the handset microphone and telephone line (sending), or between the telephone line and the handset speaker (receiving), or between the microphone and the telephone line (sending), or between the telephone line and the speaker (receiving). Check the components at that point. **Check Sheet for Signal Route** (P.123) is useful for this investigation.

2. No pulse dialling

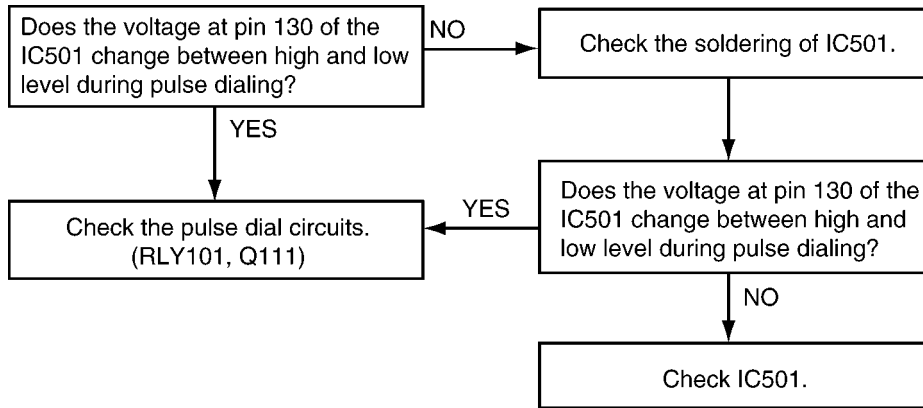

3. No ring tone (or No bell)

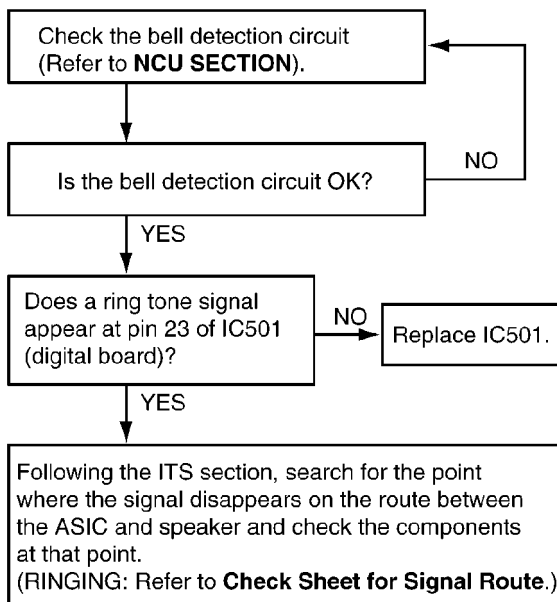

4. No tone dialling

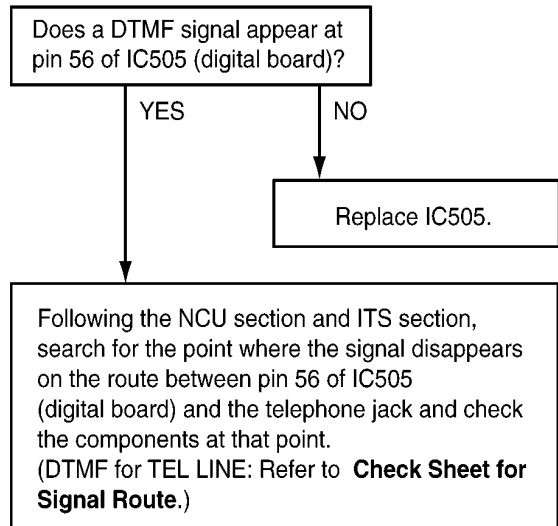

REFERENCE:
Check Sheet for Signal Route (P.123)

REFERENCE:
Check Sheet for Signal Route (P.123)
NCU Section (P.40)

12.5.7. Digital Speakerphone (KX-FP218)

The digital speakerphone has different features from the analog speakerphone. The analog speakerphone switches between Tx or Rx. Either Tx or Rx is able to pass through a telephone line or speaker, depending on the Tx and Rx signal (voice) level. The higher-level signal (either TX or RX) can pass through the route. Therefore, you never hear the other party's voice while you are talking. However, the digital speakerphone allows you to hear the other party's voice while you are talking. So both Tx and Rx are active at the same time. There is also a difference in the troubleshooting procedures between the two types.

At the start of communication, during the initial 2~3 correspondences, the digital speakerphone performs half-duplex operation, alternating between transmission (Tx) and reception (Rx). Then duplex communication becomes available. Learning occurs during the initial 2~3 correspondences in order to set the appropriate parameters for duplex communication.

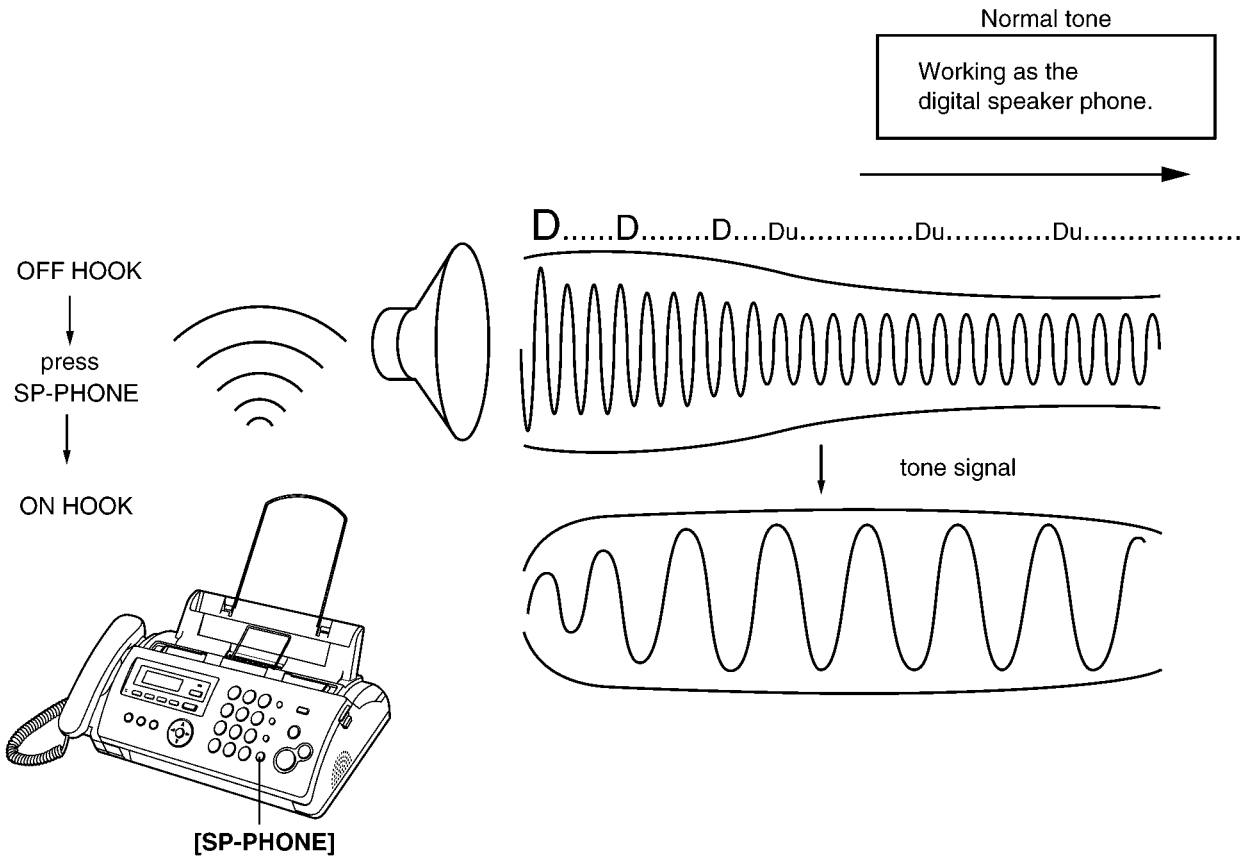

You cannot check the digital speaker phone by the signal route test mentioned in the Analog Board Section because the level is always changing as stated above.

Therefore, there is a service function for this troubleshooting. In this service mode, you can set the mute to either Tx or Rx. Then you can check the signal route of the speaker phone Tx or the speaker phone Rx without any disturbances.

HOW TO USE THE #841 SERVICE FUNCTION for THE DIGITAL SPEAKER PHONE

Please check by using the service function ([#],[9][0][0][0][*],[8][4][1])

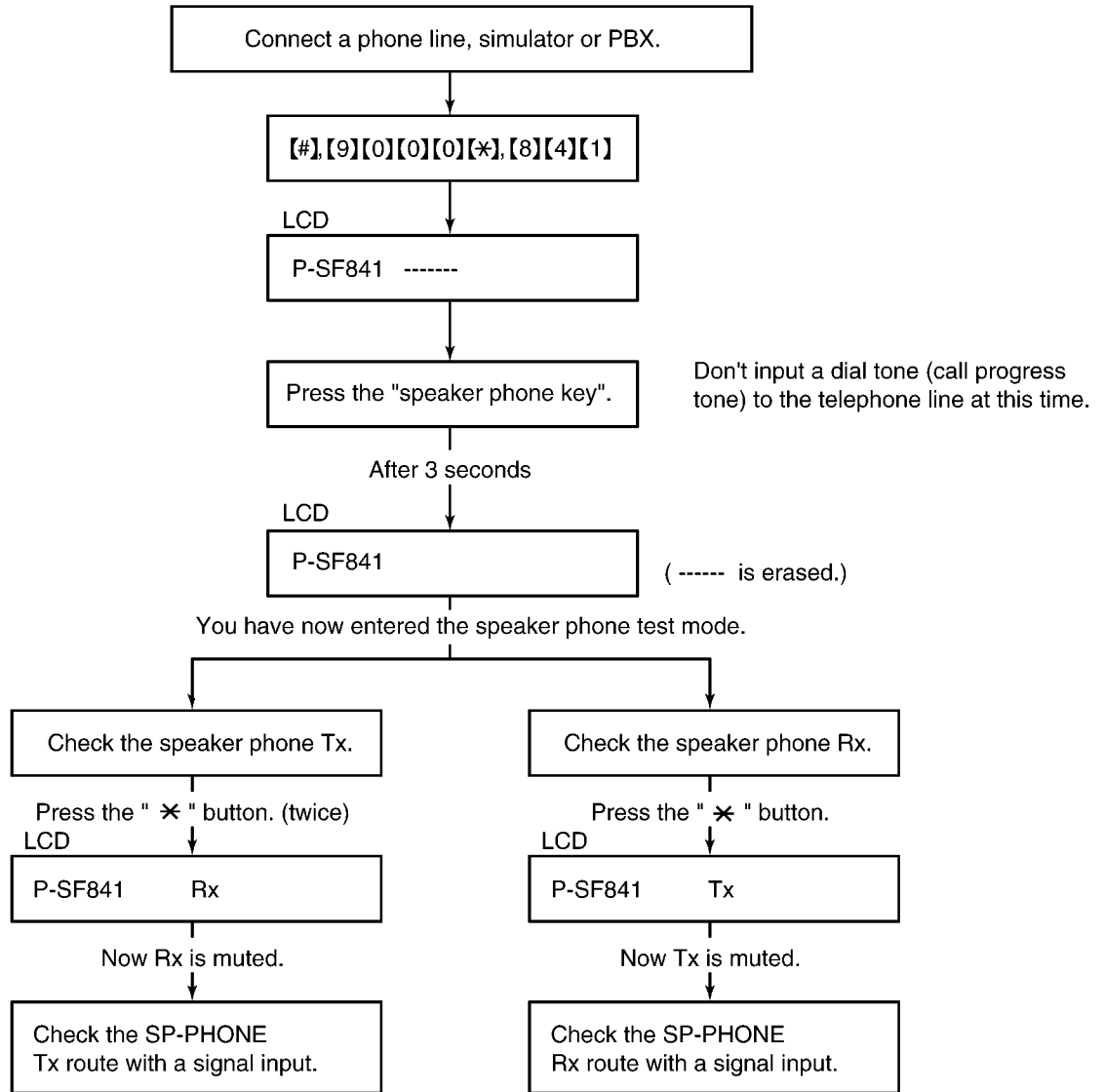

Note:

Check to the SP-Phone Rx/Tx signal routes. (Refer to **Check Sheet for Signal Route** (P.123)).

12.5.8. Power Supply Board Section

12.5.8.1. Key Components for Troubleshooting

Check the following parts first: F101, D101-D104, C106, Q101 and IC101.

This comes from our experience with experimental tests. For example: power supply and lightning surge voltage test, withstanding voltage test, intentional short circuit test, etc.

Caution:

If you find a melted fuse in the unit, do not turn on the power until you locate and repair the faulty parts (except for the fuse); otherwise the fuse will melt again and you cannot pinpoint the faulty point.

In most cases, the symptom is that nothing is output. It is more likely that the fault is in the primary side rather than the secondary side. Check the primary side first.

POWER SUPPLY BLOCK DIAGRAM

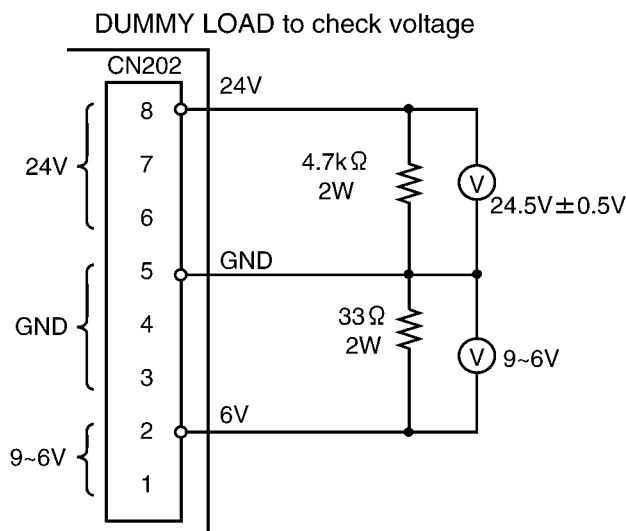
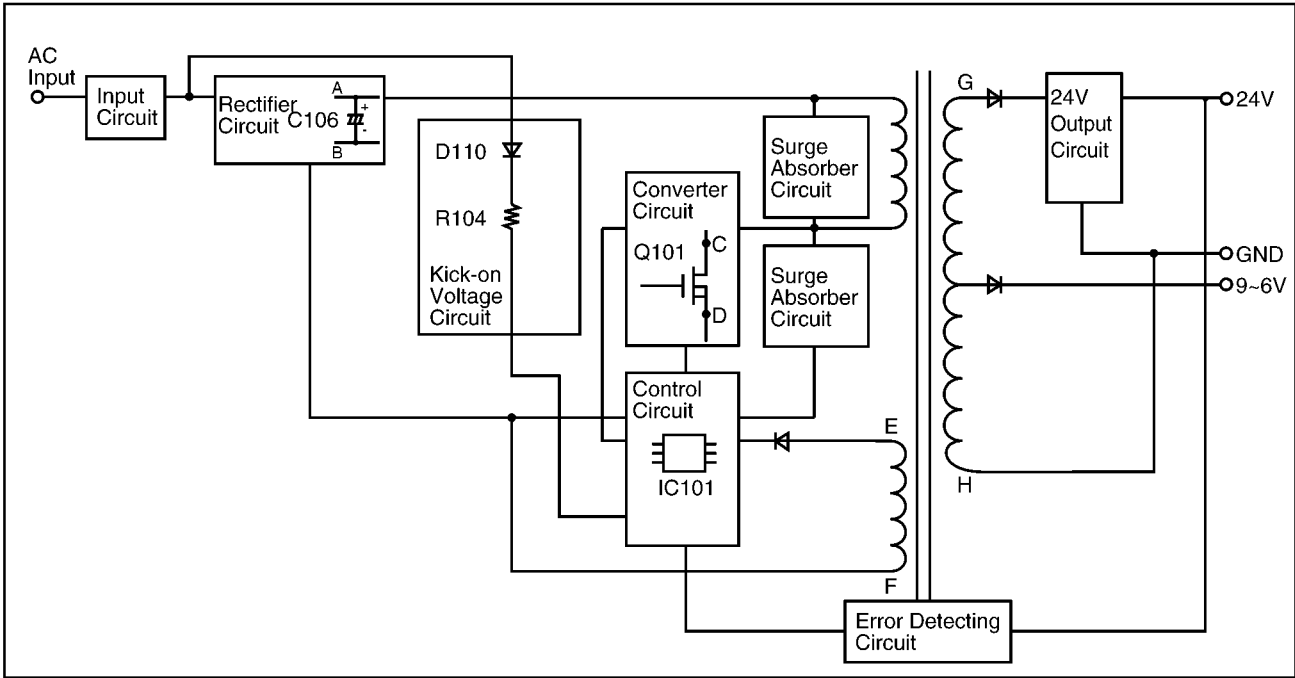

(When you check voltage in a power supply unit alone, use this dummy load. If the dummy load is not available, connect the main P.C.B. to the digital P.C.B.)

(V) : Volt Meter

12.5.8.2. Troubleshooting Flow Chart

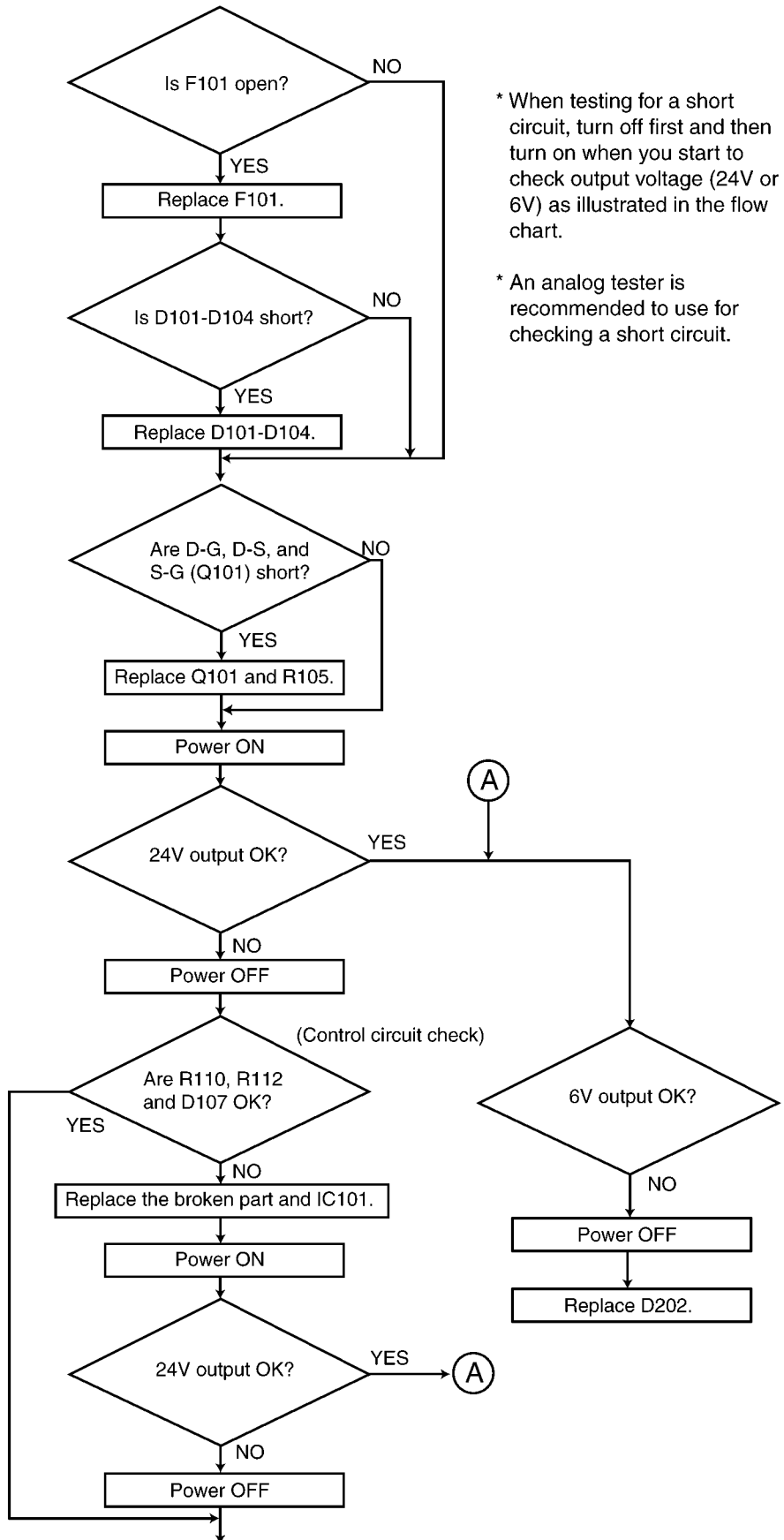

* When testing for a short circuit, turn off first and then turn on when you start to check output voltage (24V or 6V) as illustrated in the flow chart.

* An analog tester is recommended to use for checking a short circuit.

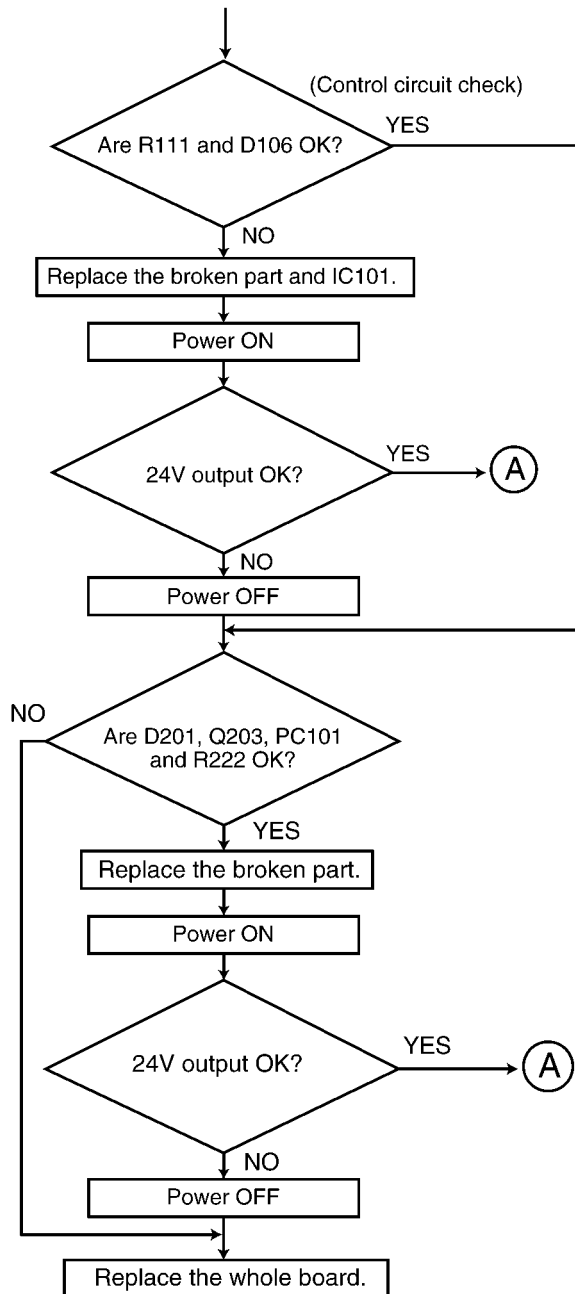

12.5.8.3. Broken Parts Repair Details

(D101, D102, D103, D104)

Check for a short-circuit in terminal 4. If D101, D102, D103 and D104 are short-circuits, F101 will melt (open). In this case, replace all of the parts (D101, D102, D103, D104, F101).

(Q101)

The worst case of Q101 is a short-circuit between the Drain and Gate because damage expands to the peripheral circuit of Q101. This is due to a very high voltage through the Gate circuit which is composed of R110, R112, D107 and IC101. You should change all of the parts listed as follows.

F101, Q101, R110, R112, D107, IC101

(D201)

If D201 is broken, the oscillation circuit in the power supply cannot operate. Check it with an electric tester.

12.5.9. Operation Panel Section

12.5.9.1. No Key Operation

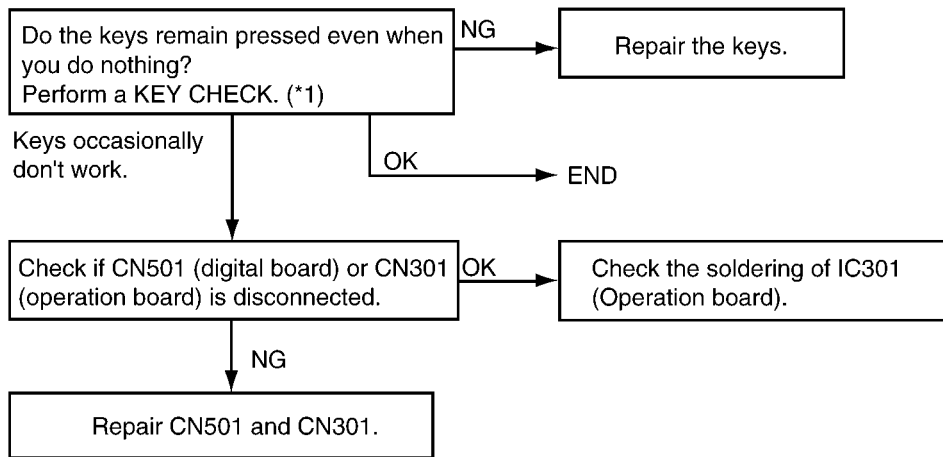

REFERENCE:

(*1): **Test Mode** (P.58)

12.5.9.2. No LCD Indication

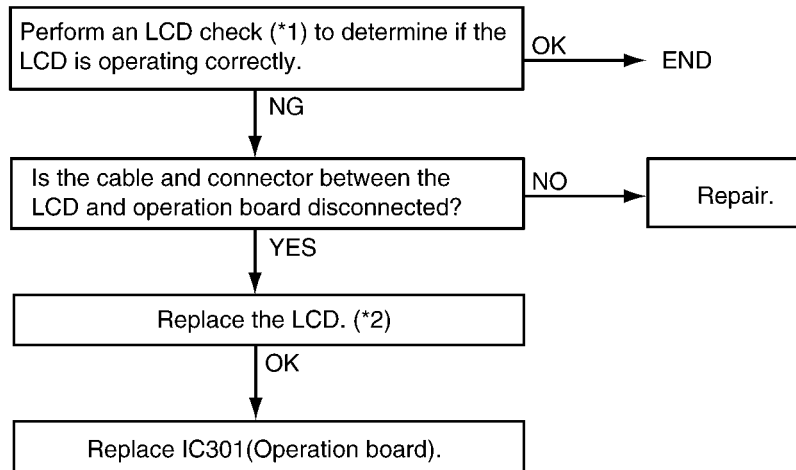

REFERENCE:

(*1): **Test Mode** (P.58)

(*2): **How to Remove the Operation Panel** (P.154)

12.5.10. Sensor Section

Refer to **Sensors and Switches** (P.29) for the circuit descriptions.

The Test Function makes the sensor circuit check easier. (Refer to **Test Mode** (P.58).)

For example, as for "COVER OPEN SENSOR", "CO" is turned ON/OFF on the display when you open or close the front cover. Also, document sensor, read position sensor, recording paper sensor and jam sensor are turned ON/OFF by the copy operation. Therefore, each sensor can be checked for proper mechanical operation.

As for the electric check, check whether each voltage is right or not with following flowchart turning each sensor lever ON/OFF manually.

12.5.10.1. Check the Document Top Sensor (SW351)....."REMOVE DOCUMENT"

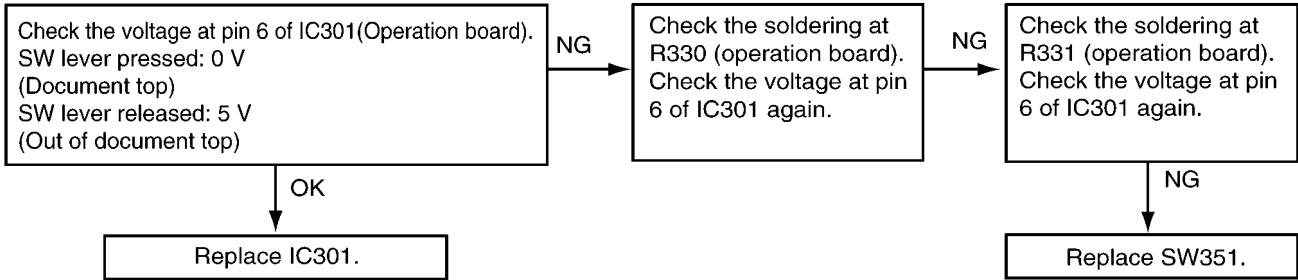

12.5.10.2. Check the Document Set Sensor (SW352)....."CHECK DOCUMENT"

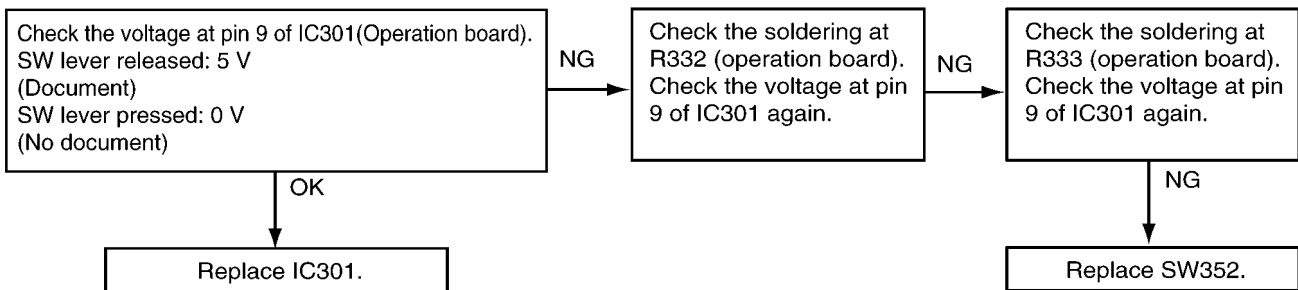

12.5.10.3. Check the Cover Open Sensor (SW1001)....."COVER OPEN"

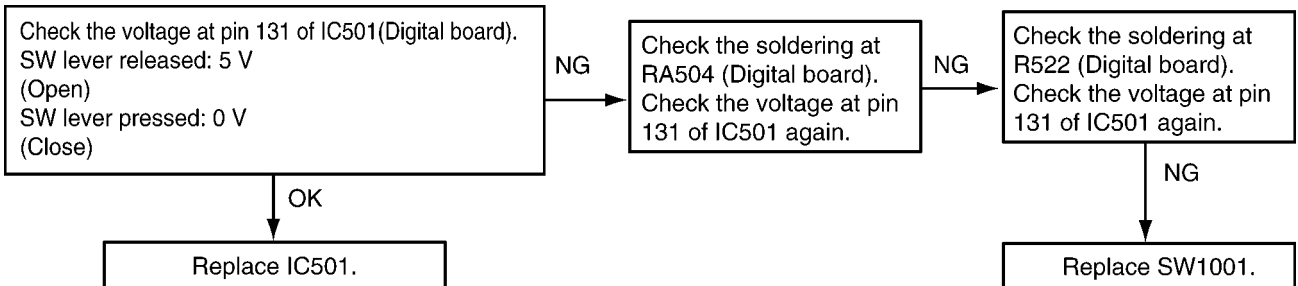

12.5.10.4. Check the Paper Top Sensor (SW1001)....."PAPER JAMMED"

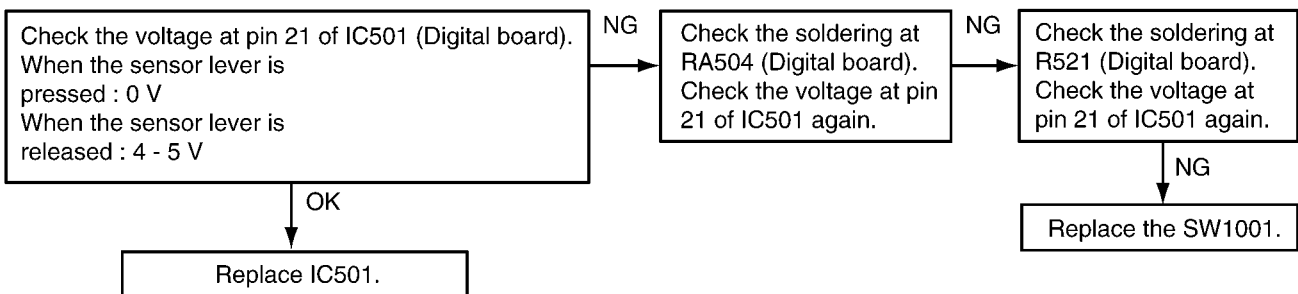

12.5.10.5. Check the Film End Sensor (SW1003)....."CHECK FILM"

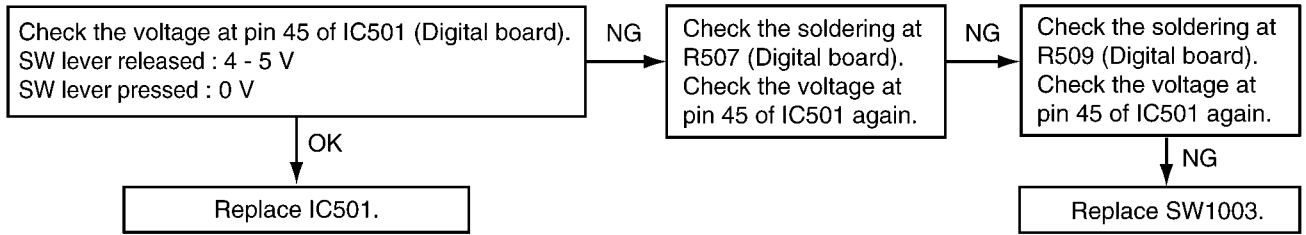

12.5.10.6. Check the Motor Position Sensor (SW1004)....."CALL SERVICE2"

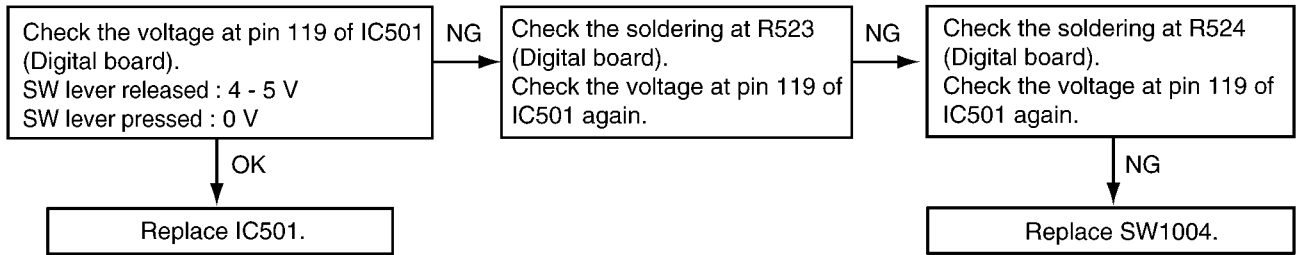

12.5.10.7. Check the HOOK Switch (SW1501)

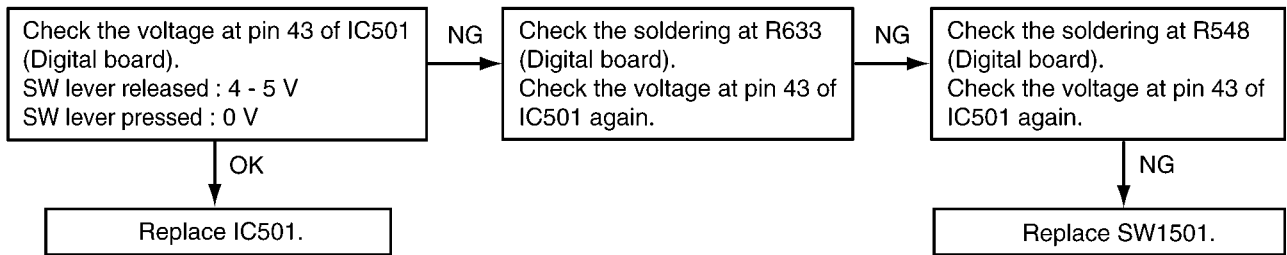

12.5.11. CIS (Contact Image Sensor) Section

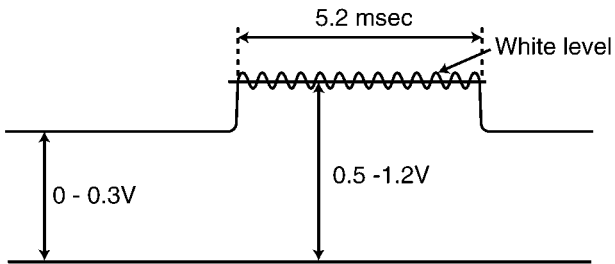
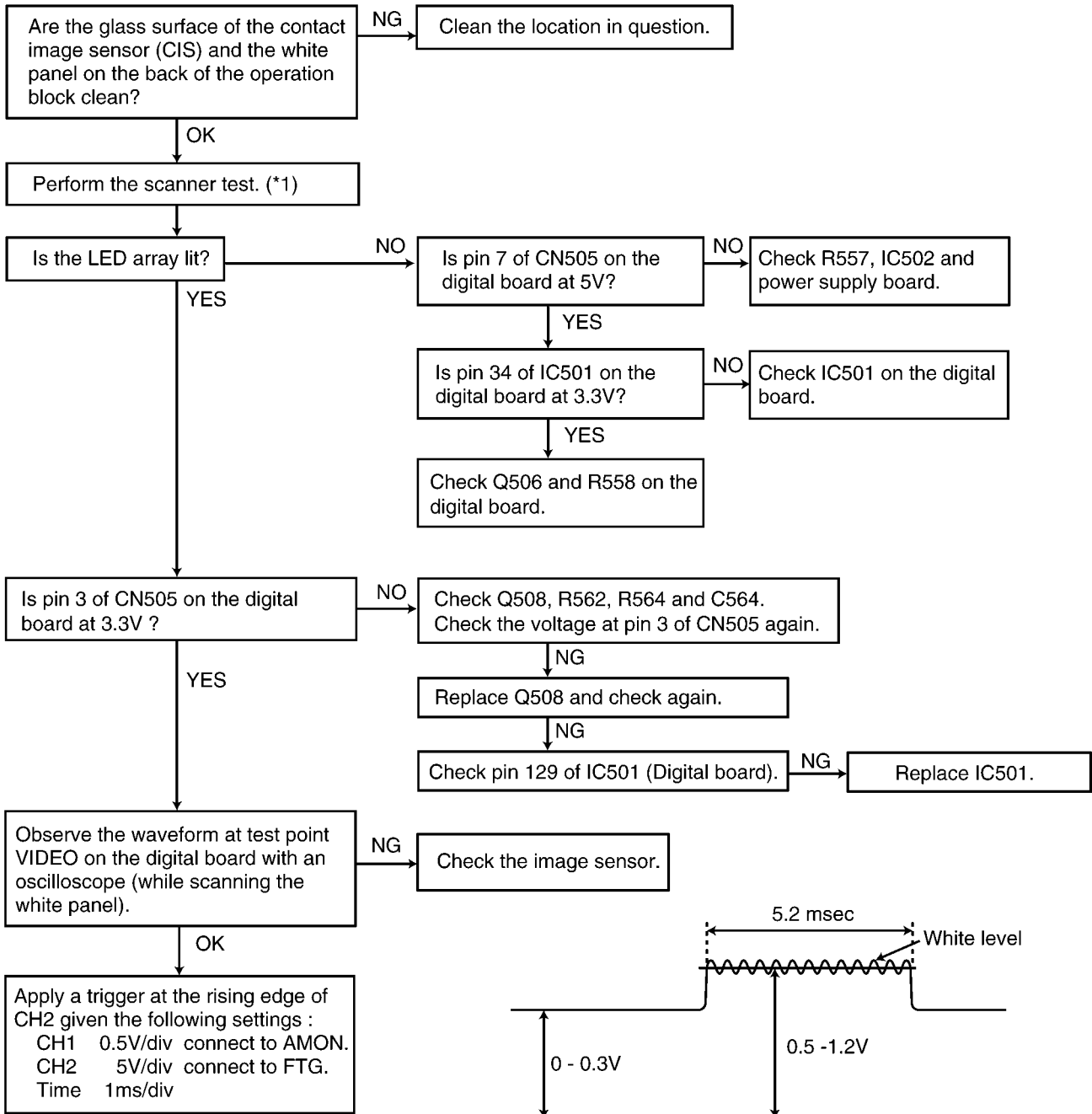

Digital Board
(Component View)

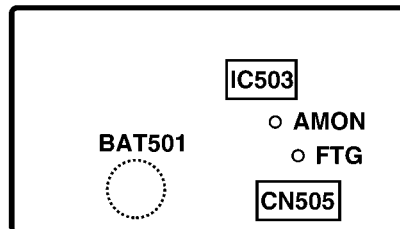

REFERENCE:

(*1): **Test Mode** (P.58)

Refer to **Scanning Block** (P.26).

12.5.12. Thermal Head Section

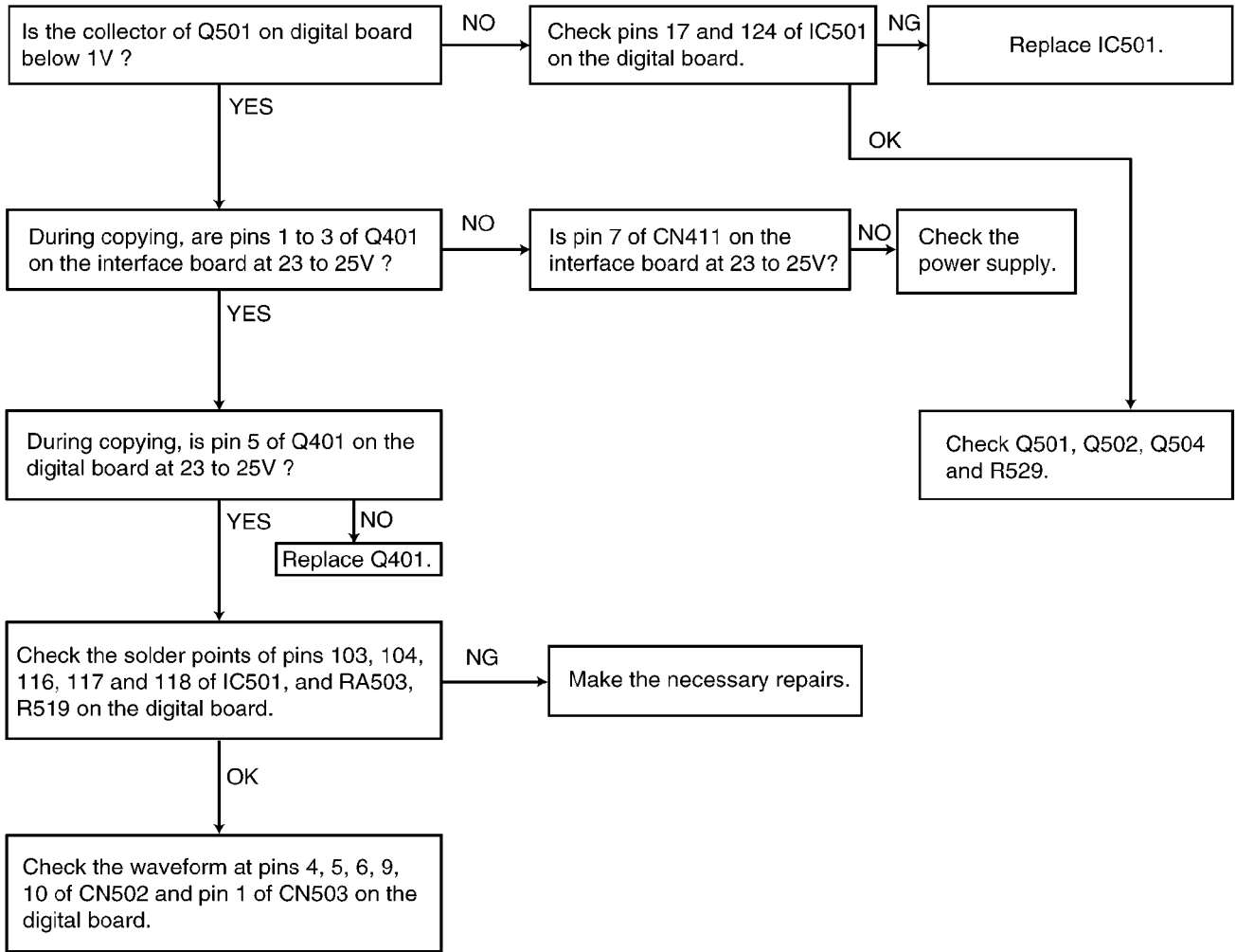

Note:

Refer to **Thermal Head** (P.24).

13 Service Fixture & Tools

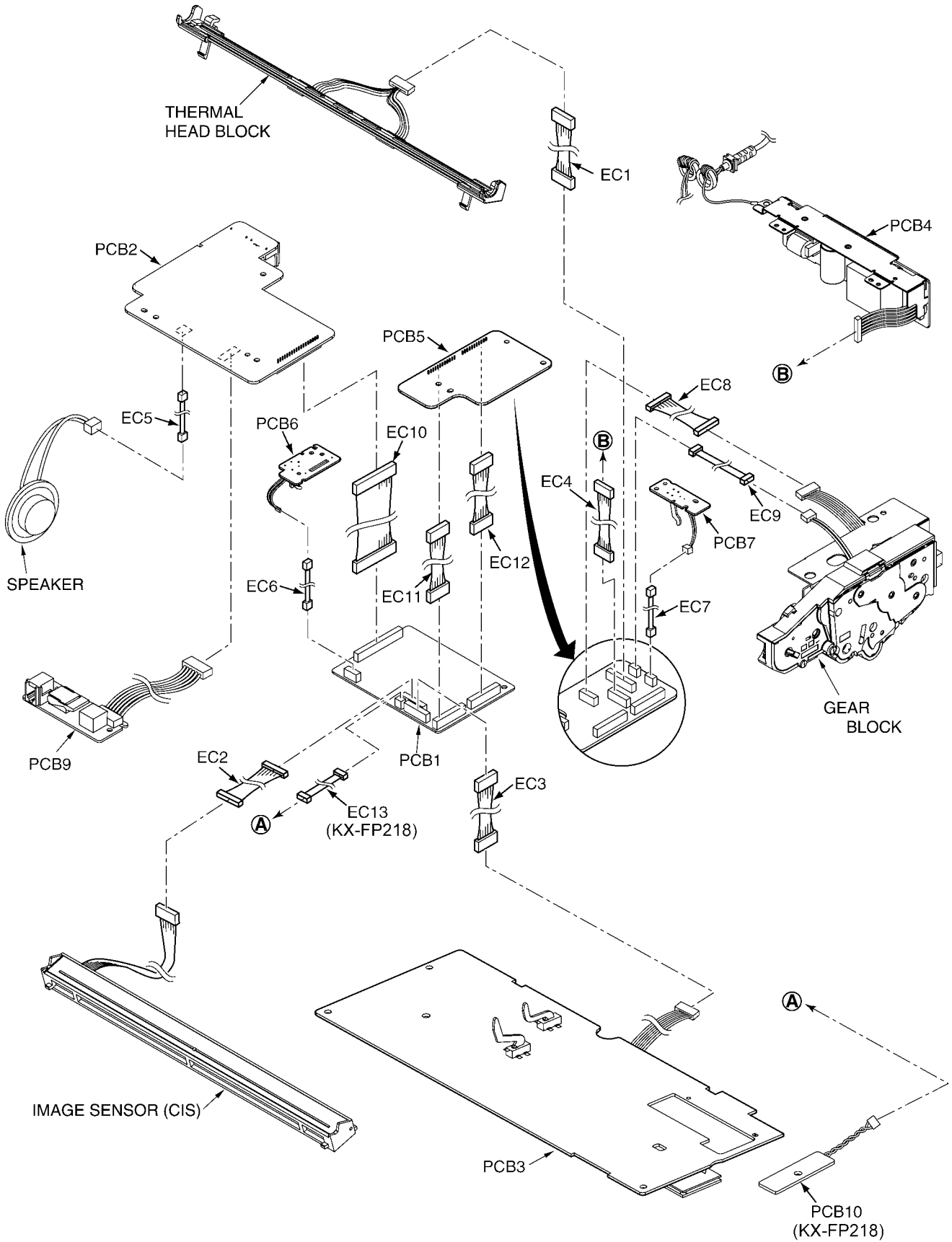

14 Disassembly and Assembly Instructions

Please remove the Paper Support Spring, Paper Tray and Ink Film before disassembling.

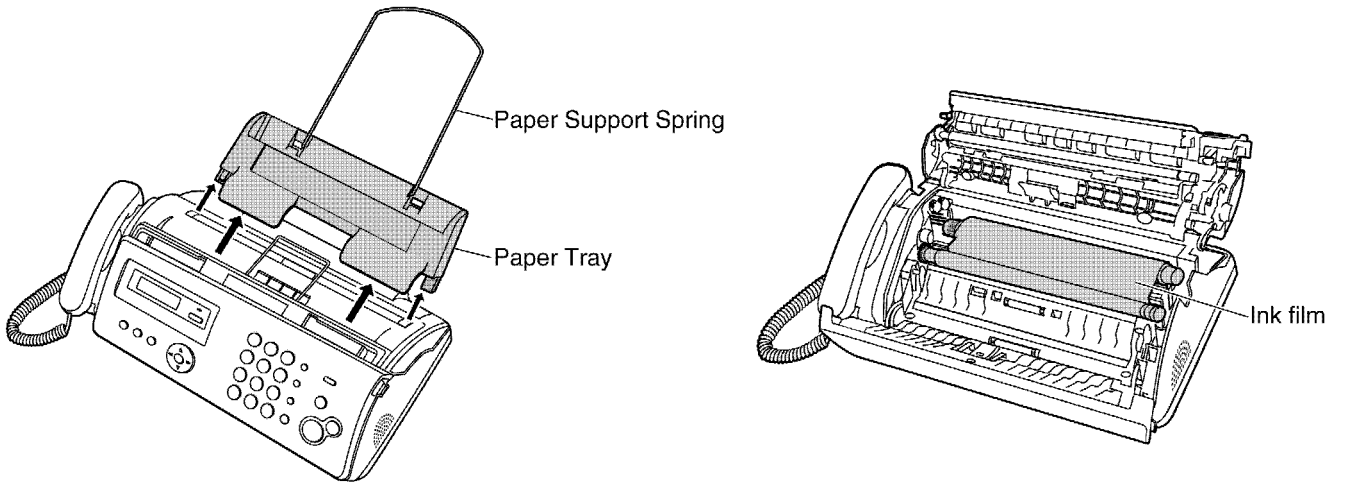

14.1. General Section

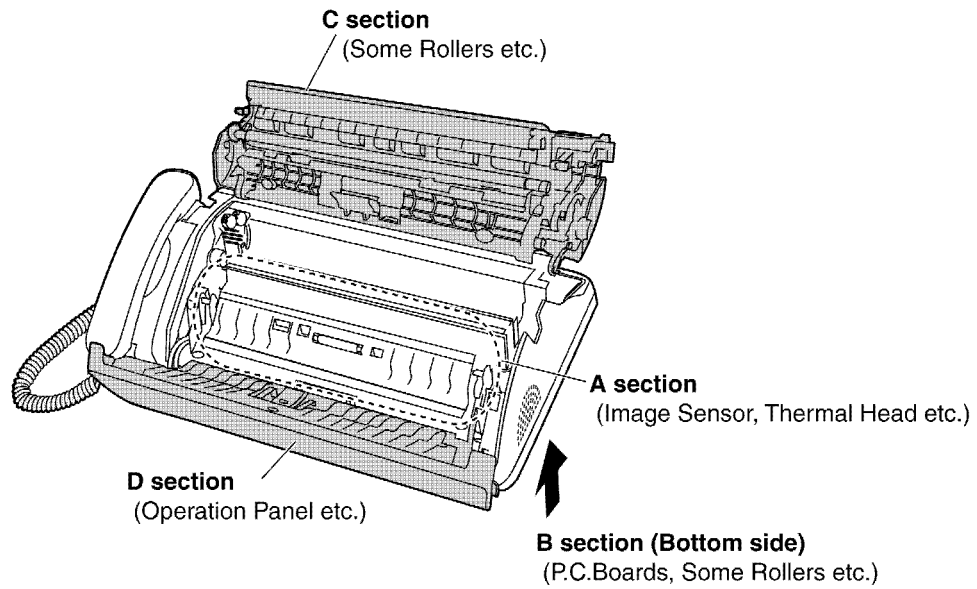

14.2. Disassembly Flowchart

14.2.1. Upper Cabinet Section

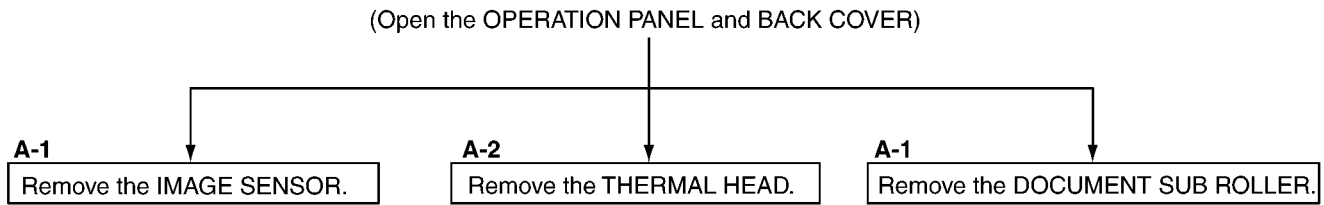

REFERENCE:

A-1: How to Remove the Image Sensor (CIS) (P.140)

A-2: How to Remove the Thermal Head (P.141)

14.2.2. Lower Cabinet Section

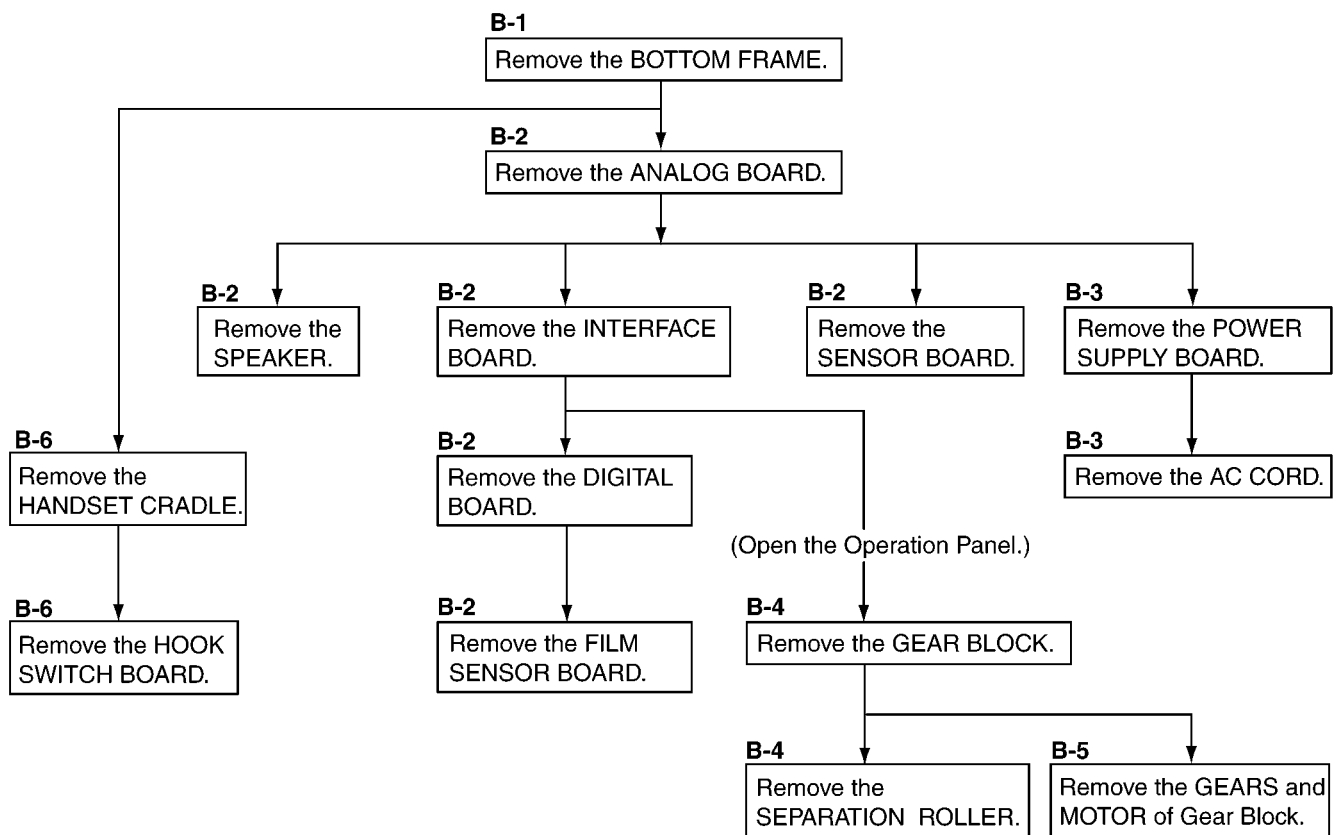

REFERENCE:

B-1: How to Remove the Bottom Frame (P.143)

B-2: How to Remove the P.C. Boards and Speaker (P.144)

B-3: How to Remove the Power Supply Board and AC cord (P.145)

B-4: How to Remove the Gear Block and Separation Roller (P.146)

B-5: How to Remove the Gears, Motors and Arms of the Gear Block (P.147)

B-6: How to Remove the Handset Cradle and Hook Switch Board (P.149)

14.2.3. Back Cover Section

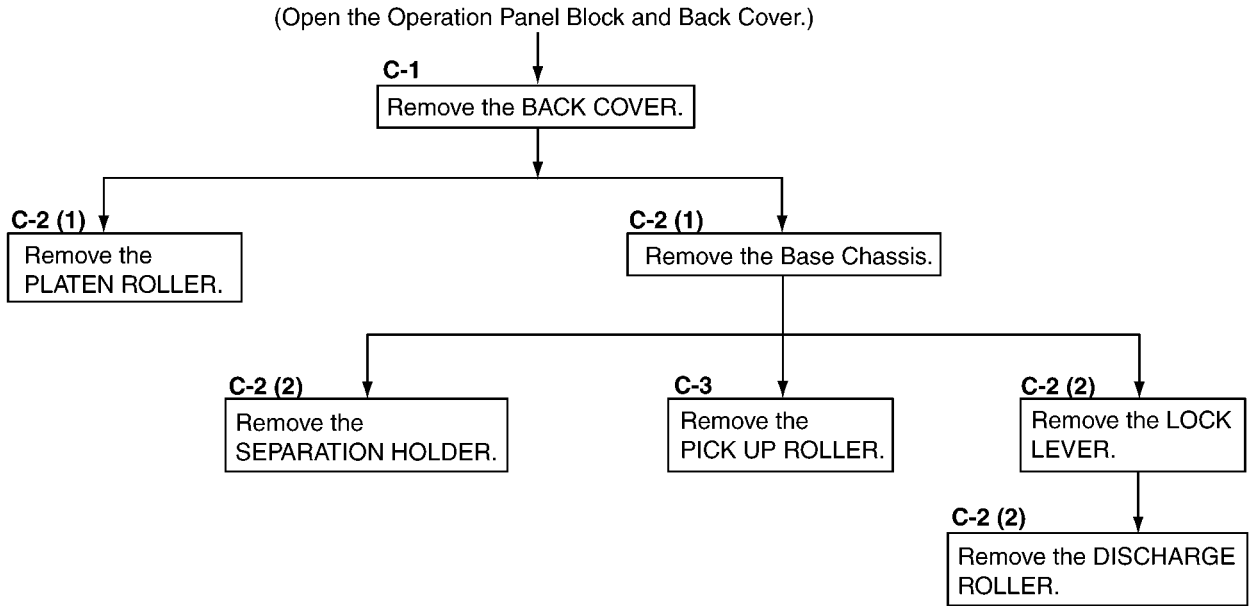

REFERENCE:

- C-1: How to Remove the Back Cover (P.150)
- C-2: How to Remove the Platen Roller and Lock Lever (P.151)
- C-3: How to Remove the Pickup Roller (P.153)

14.2.4. Operation Panel Section

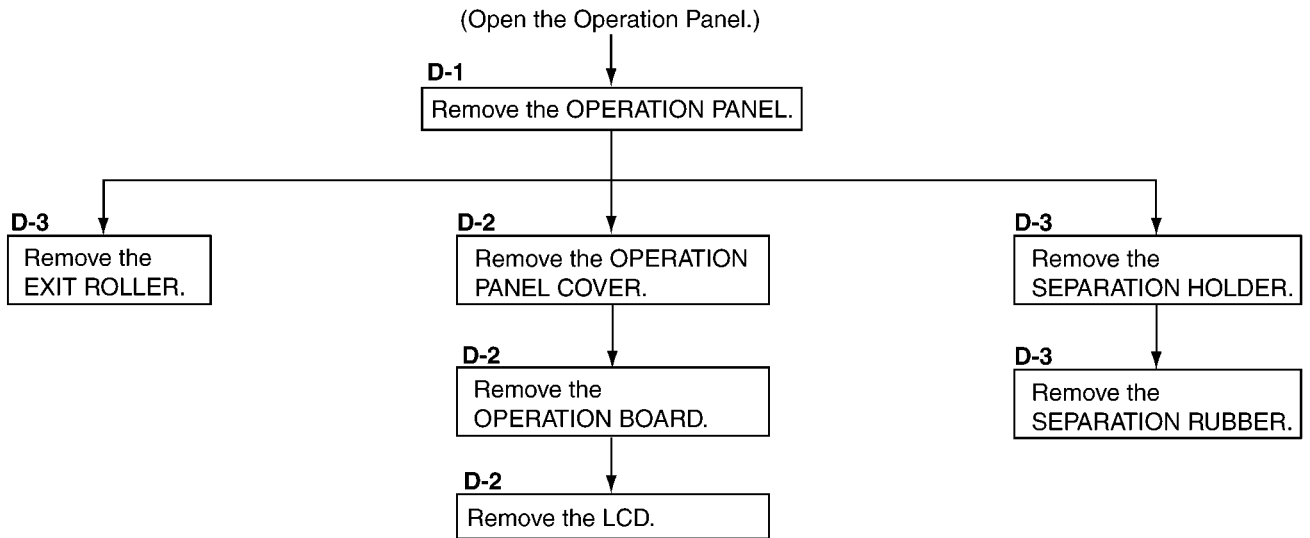

REFERENCE:

- D-1: How to Remove the Operation Panel (P.154)
- D-2: How to Remove the Operation Board and LCD (P.155)
- D-3: How to Remove the Separation Holder and Exit Roller (P.157)

14.3. Disassembly Procedure

14.3.1. How to Remove the Image Sensor (CIS)

PROCEDURE: A-1

Ref. No. A-1

IMAGE SENSOR

- 1) Push the Green Button to open the Operation Panel and Back Cover.
- 2) Remove the 2 screws (D).
- 3) Remove the IMAGE SENSOR from the Main Cabinet, as shown in a Fig. A.
- 4) Disconnect the Connector.

DOCUMENT SUB ROLLER

- 1) Push the Green Button to open the Operation Panel and Back Cover.
- 2) Remove the DOCUMENT SUB ROLLER, as shown in a Fig. B.

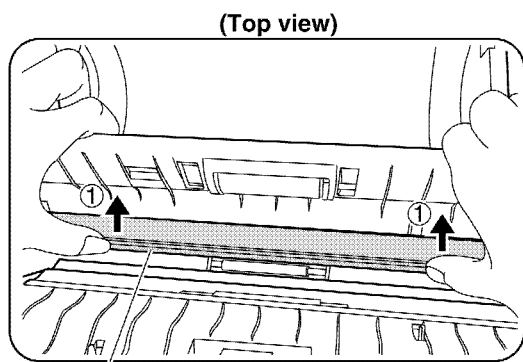
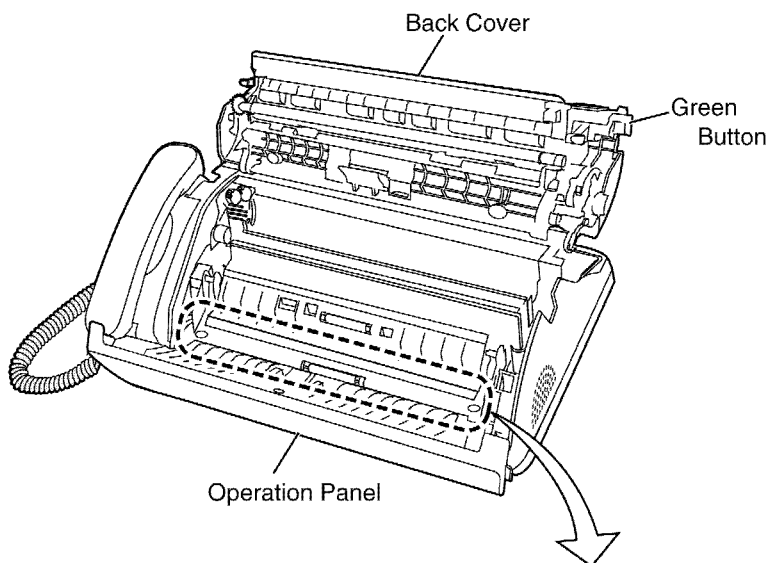
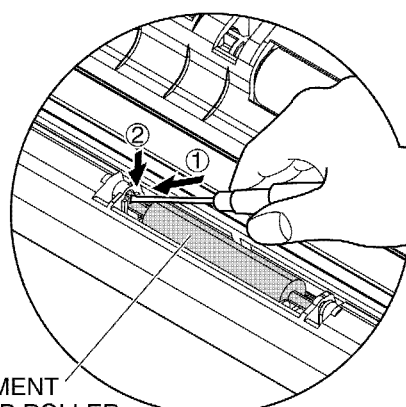
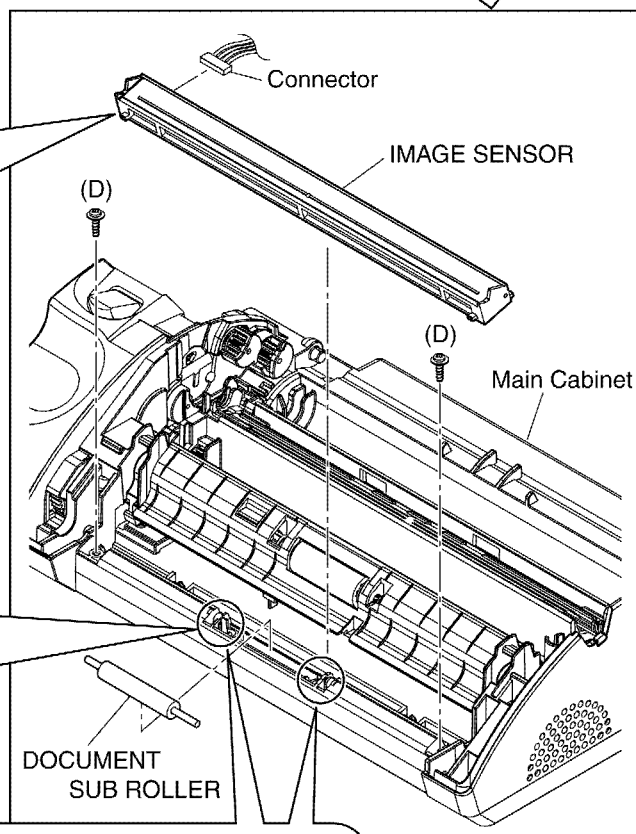
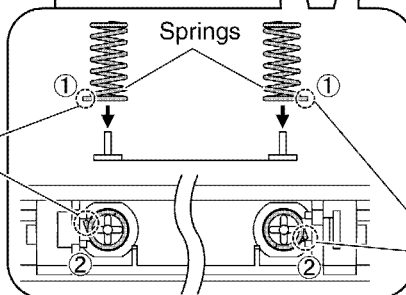

IMAGE SENSOR



DOCUMENT SUB ROLLER



Note for Assembly:

- ① Be careful up-down direction of spring.
- ② Install the tip of the spring in the direction, as shown in the Fig. E.

14.3.2. How to Remove the Thermal Head

PROCEDURE: A-2

Ref. No. A-2

- 1) Push the Green Button to open the Operation Panel and Back Cover.
- 2) Release the both-side hooks of Thermal Head Holder from Main Cabinet. (Refer to next page.)
Remove the holder from thermal head after releasing this stopper. (Fig. C)
- 3) Disconnect the Connectors.
- 4) Remove the THERMAL HEAD.

Note for Assembly:

- When springs are inserted in the Main Cabinet, be careful in the direction of springs. (See Fig. D)

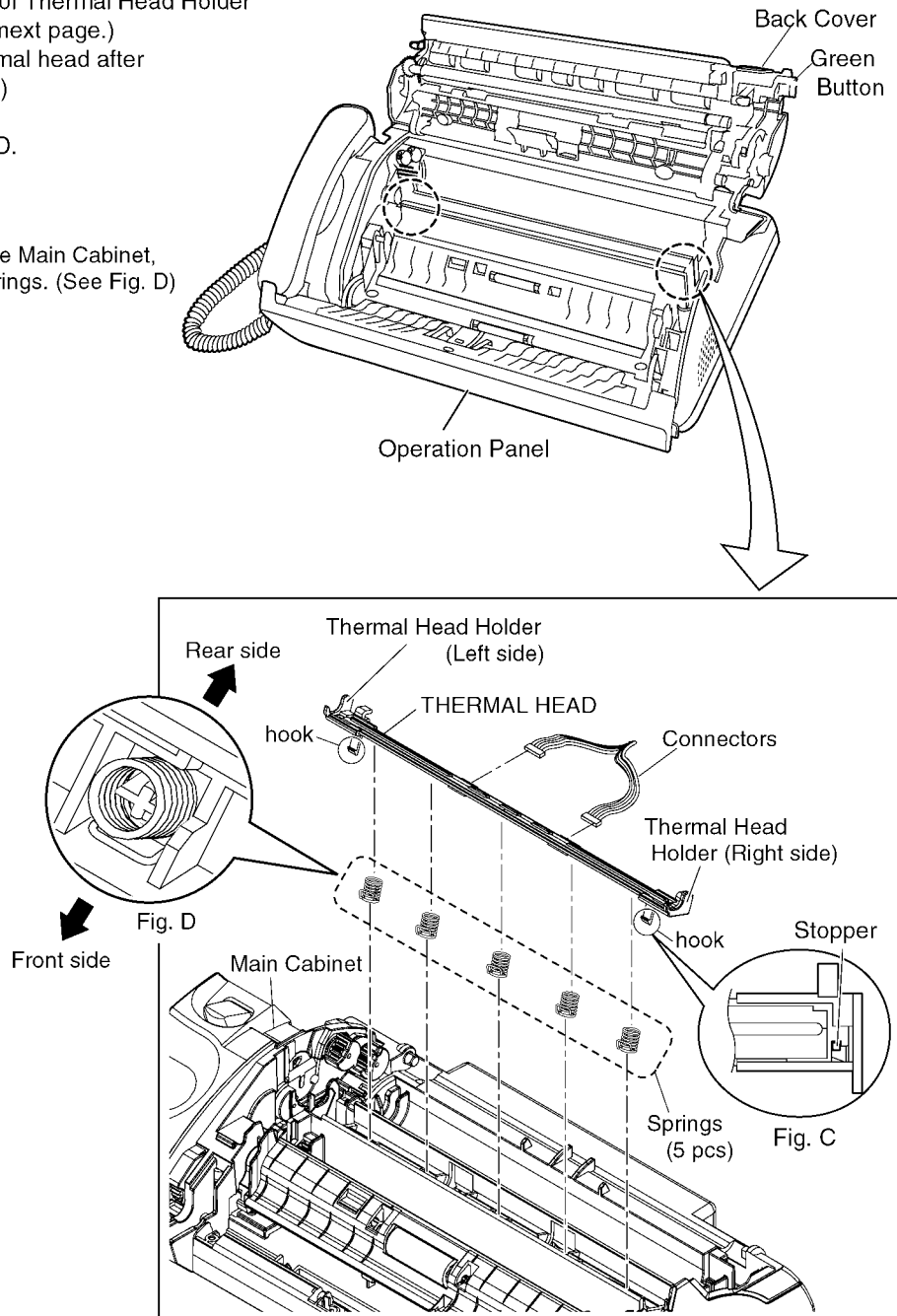

Ref. No. A-2 (2)

① Push the left side hook first, as shown in a figure.

CORRECT

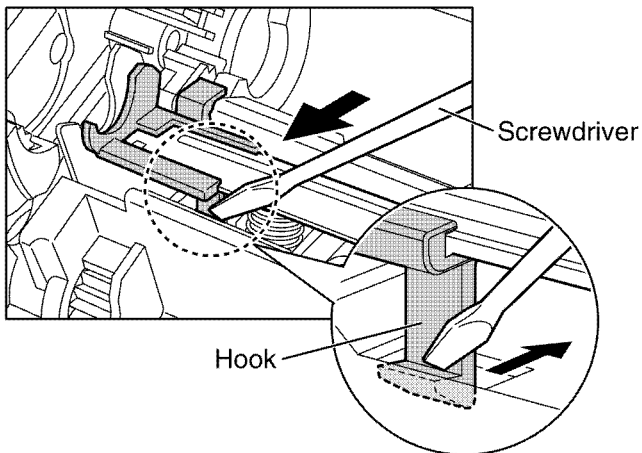

INCORRECT

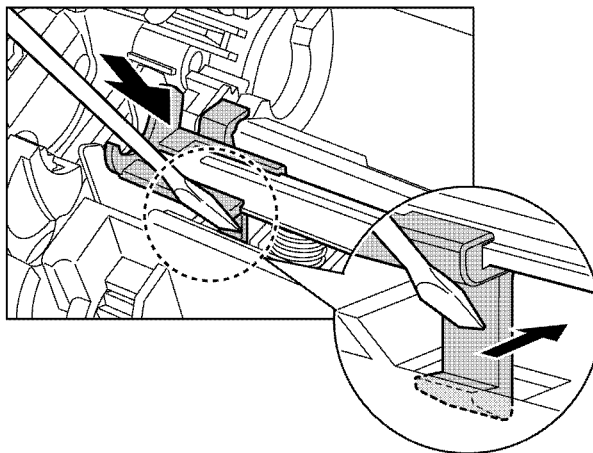

② Keep a left side hook situation and push the right side hook, as shown in a figure.

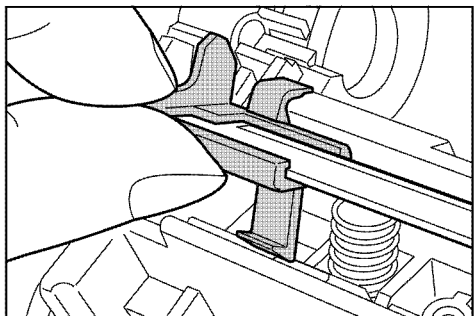

SIDE VIEW

CORRECT

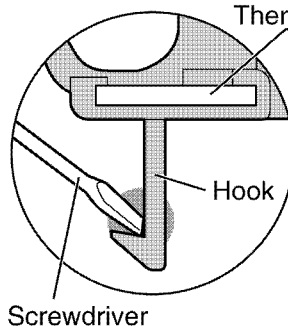

INCORRECT

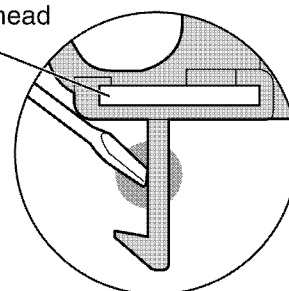

③ Push the right side hook, as shown in a figure. The both side hooks release from Main Cabinet.

CORRECT

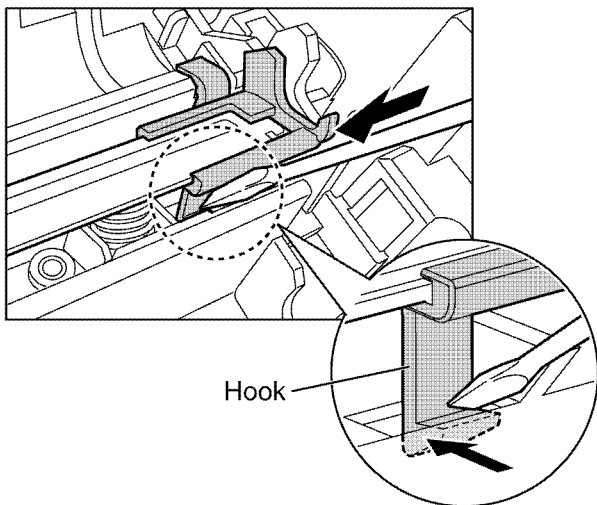

INCORRECT

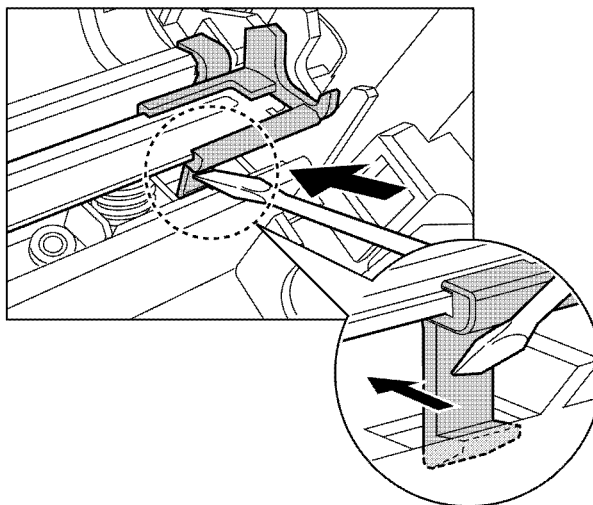

14.3.3. How to Remove the Bottom Frame

PROCEDURE: B-1**Ref. No. B-1**

- 1) Remove the 7 screws (F) and 1 screw (B).
- 2) Remove the BOTTOM FRAME.

Note for Assembly:

- Fasten ①, ② and ③ screws first.
(Order is ①→②→③.)
- When Bottom Frame is installed in the Main Cabinet, be careful not to run aground into the bosses.

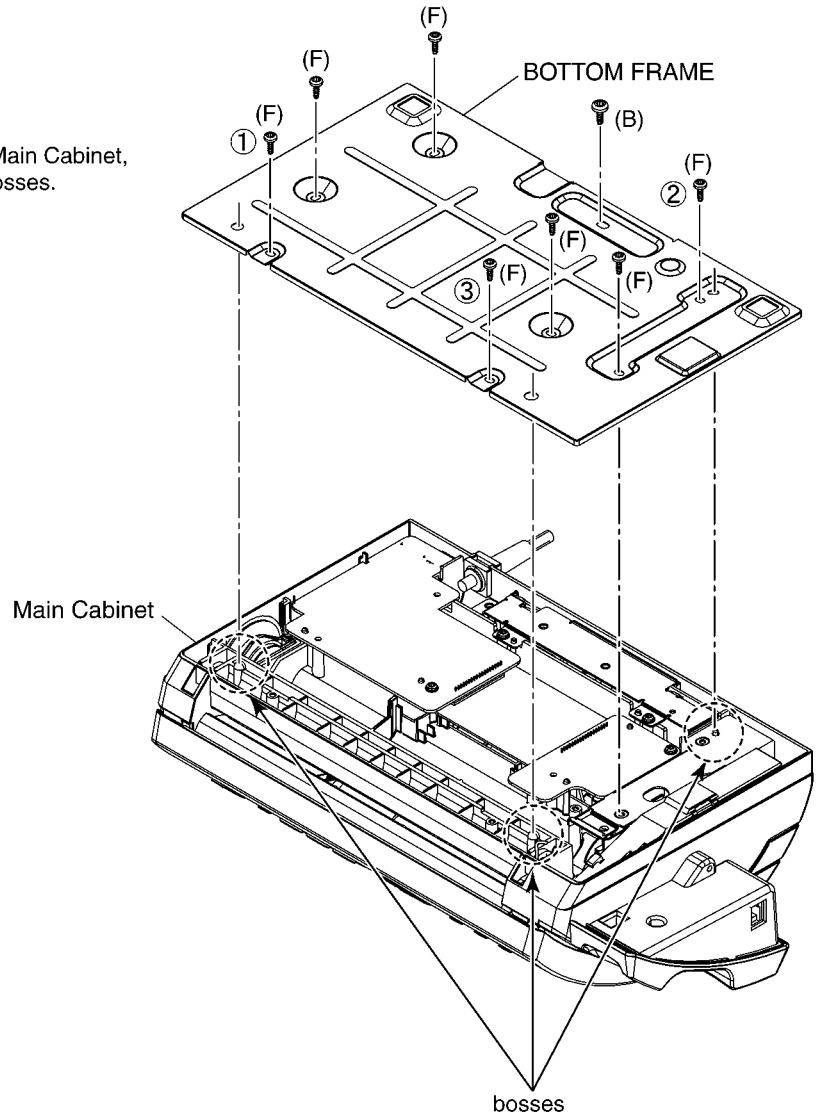

14.3.4. How to Remove the P.C. Boards and Speaker

PROCEDURE: B-1→B-2

Ref. No. B-2

ANALOG BOARD

- 1) Remove the 1 screw (F)-a.
- 2) Disconnect the Connector on the Analog Board.
- 3) Remove the ANALOG BOARD.

INTERFACE BOARD

- 1) Remove the 1 screw (F)-b.
- 2) Disconnect the Connectors on the Interface Board.
- 3) Remove the INTERFACE BOARD.

DIGITAL BOARD

- 1) Remove the Analog Board.
- 2) Remove the Interface Board.
- 3) Remove the 1 screw (F)-c.
- 4) Disconnect the Connectors on the Digital Board.
- 5) Release the hooks of the Main Cabinet.
- 6) Remove the DIGITAL BOARD.

FILM END SENSOR BOARD

- 1) Remove the Analog Board.
- 2) Remove the Interface Board.
- 3) Remove the Digital Board.
- 4) Remove the 2 screws (F)-d.
- 5) Disconnect the Connectors on the Film End Sensor Board.
- 6) Remove the FILM END SENSOR BOARD.

SENSOR BOARD

- 1) Remove the Analog Board.
- 2) Remove the 2 screws (F)-e.
- 3) Remove the SENSOR BOARD.

SPEAKER

- 1) Remove the Analog Board.
- 2) Remove the 1 screw (F)-f.
- 3) Remove the SPEAKER.

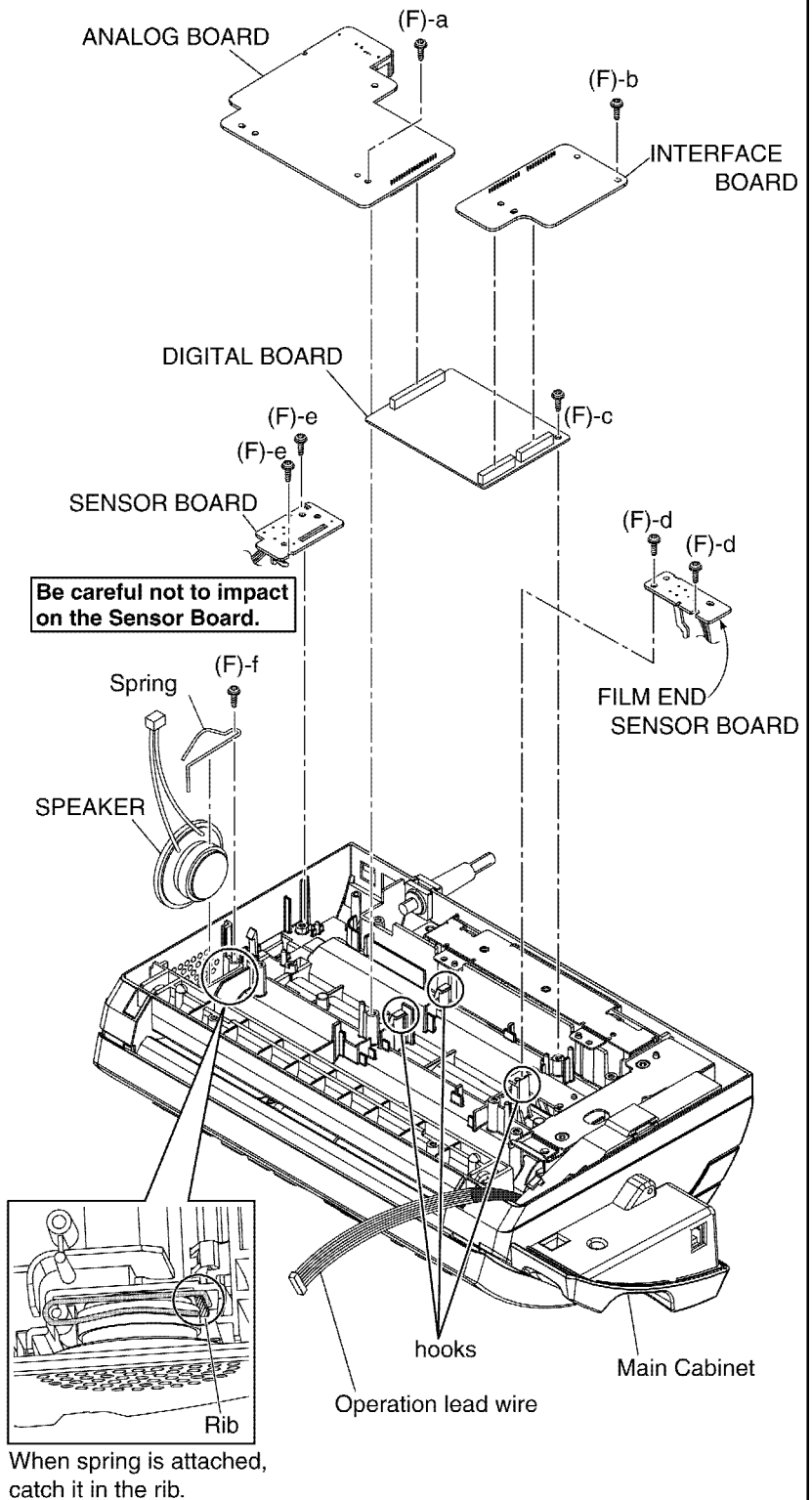

14.3.5. How to Remove the Power Supply Board and AC cord

PROCEDURE: B-1→B-2→B-3

Ref. No. B-3

- 1) Remove the Analog Board. (Refer to B-2.)
- 2) Remove the 2 screws (F).
- 3) Remove the Power Supply Board with AC Cord from Main Cabinet.
- 4) Remove the 1 screw (B).
- 5) Unsolder the Point-B. (See Fig. G)
- 6) Remove the POWER SUPPLY BOARD and AC CORD.

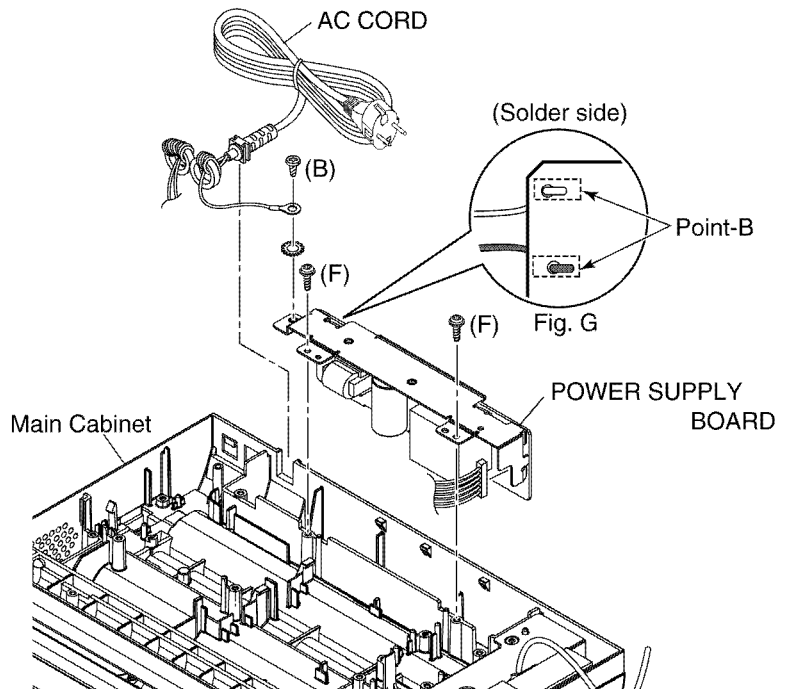

The soldering of AC Cord

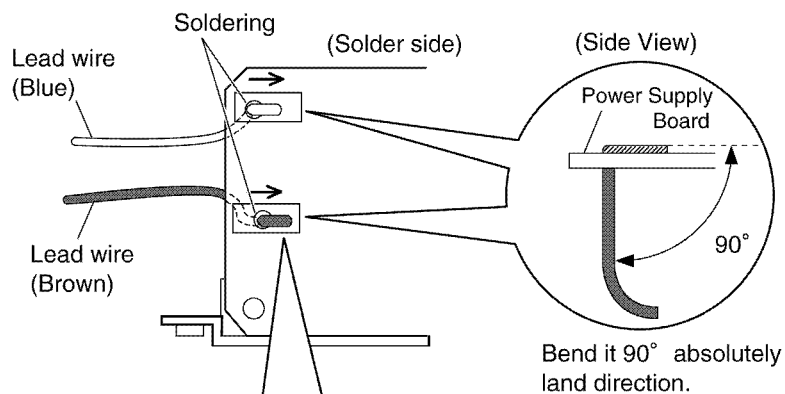

Correct	Incorrect

land

Note:

- As to the lead wires, take care not to protrude from the land area.
- Check lead wire situation and confirm no-cut and no-whiskers.

14.3.6. How to Remove the Gear Block and Separation Roller

PROCEDURE: B-1→B-2→B-4

Ref. No. B-4

- 1) Remove the Interface Board. (Refer to B-2.)
- 2) Remove the 3 screws (F).
- 3) Open the Operation Panel. (See Fig. H)
- 4) Remove the GEAR BLOCK.
- 5) Release the hook, as shown in a Fig. J.
- 6) Pull out the Separation Shaft.
- 7) Remove the SEPARATION ROLLER.

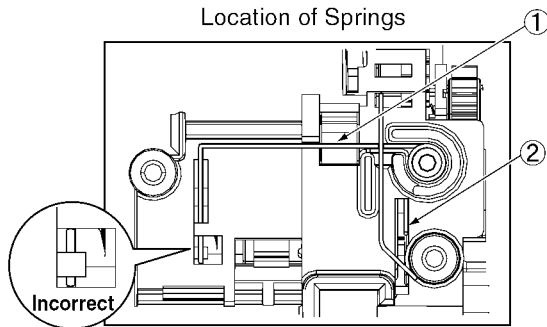
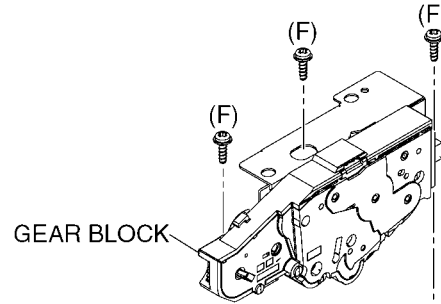

- ① Insert the Head Earth Spring along rib.
- ② Insert the Platen Earth Spring to hole.

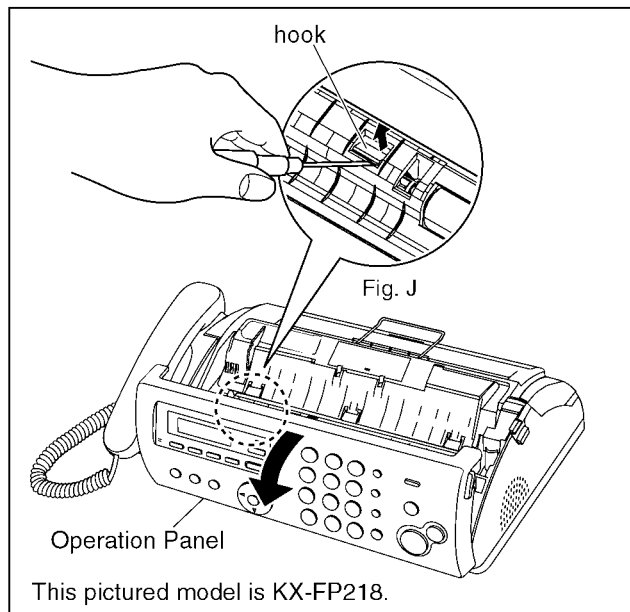
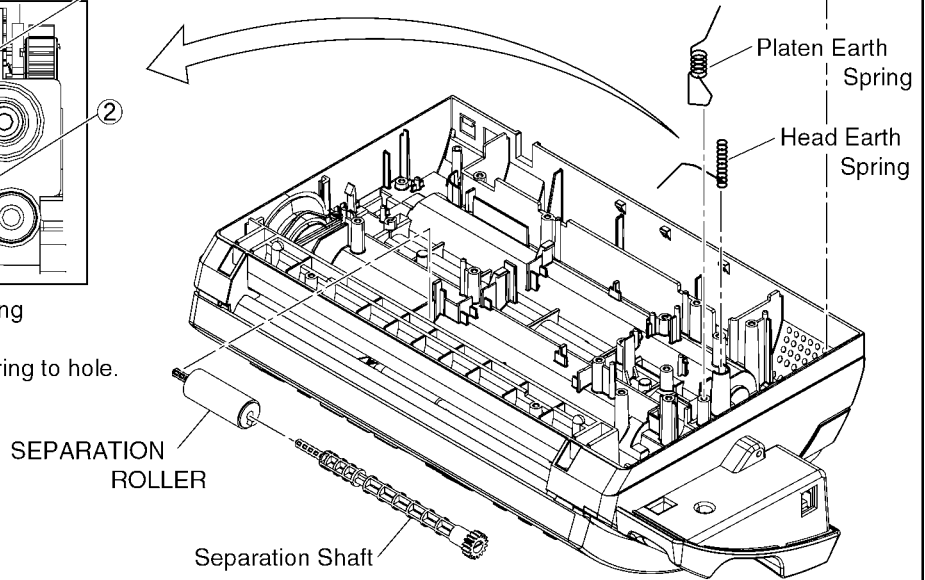

Fig. H

14.3.7. How to Remove the Gears, Motors and Arms of the Gear Block

PROCEDURE: B-1→B-2→B-4→B-5

Ref. No. B-5 (1)

- 1) Remove the 2 screws (E)-a.
- 2) Remove the Plate and MOTOR.
- 3) Remove the 5 screws (E)-b.
- 4) Remove the Cover after release the hooks.

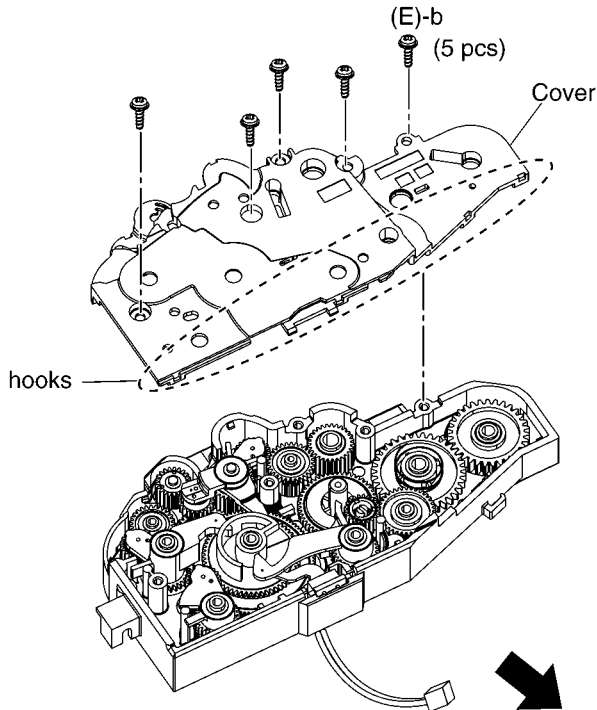

- 5) Remove the Arm-a.
- 6) Remove the Switch.
- 7) Remove the Arm-b and Arm-c.
- 8) Remove the Arm-d and Arm-e.
- 9) Remove the Gear-a.
- 10) Remove the Spring-a.
- 11) Remove the Gear-b.

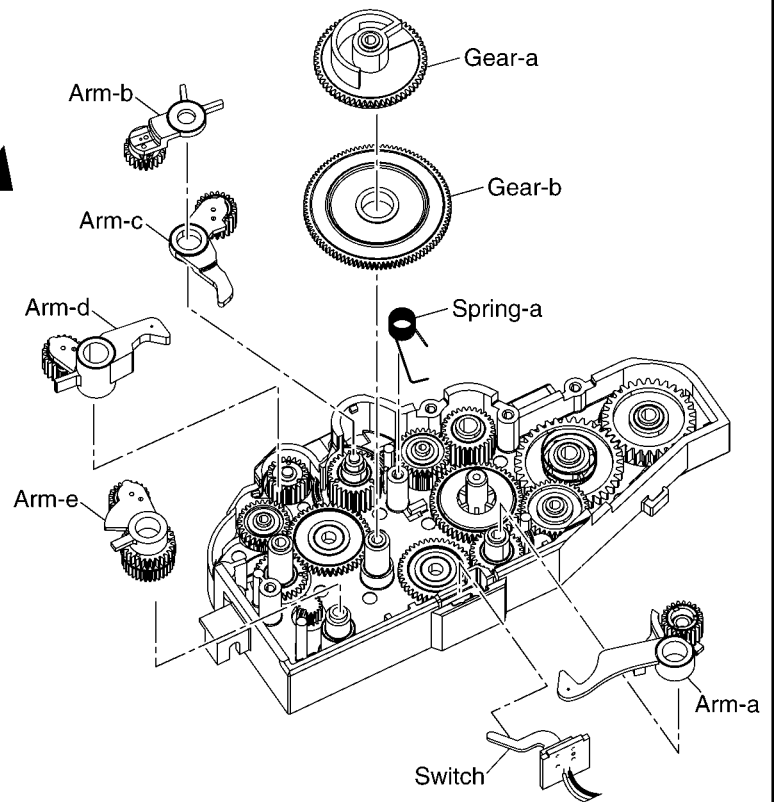

Ref. No. B-5 (2)

- 12) Remove the Gear-c.
- 13) Remove the Spring-b.
- 14) Remove the Gear-d.
- 15) Remove the Ratchet and Gear-e.
- 16) Remove the Gear (Torque Limiter).
- 17) Remove the Gear-f.
- 18) Remove the Gear-g and Gear-h.
- 19) Remove the Gear-j.
- 20) Remove the Gear-k.
- 21) Remove the Gear-m.
- 22) Remove the Gear-n.
- 23) Remove the Gear-p.
- 24) Remove the Gear-r.
- 25) Remove the Gear-s.
- 26) Remove the Gear-t.

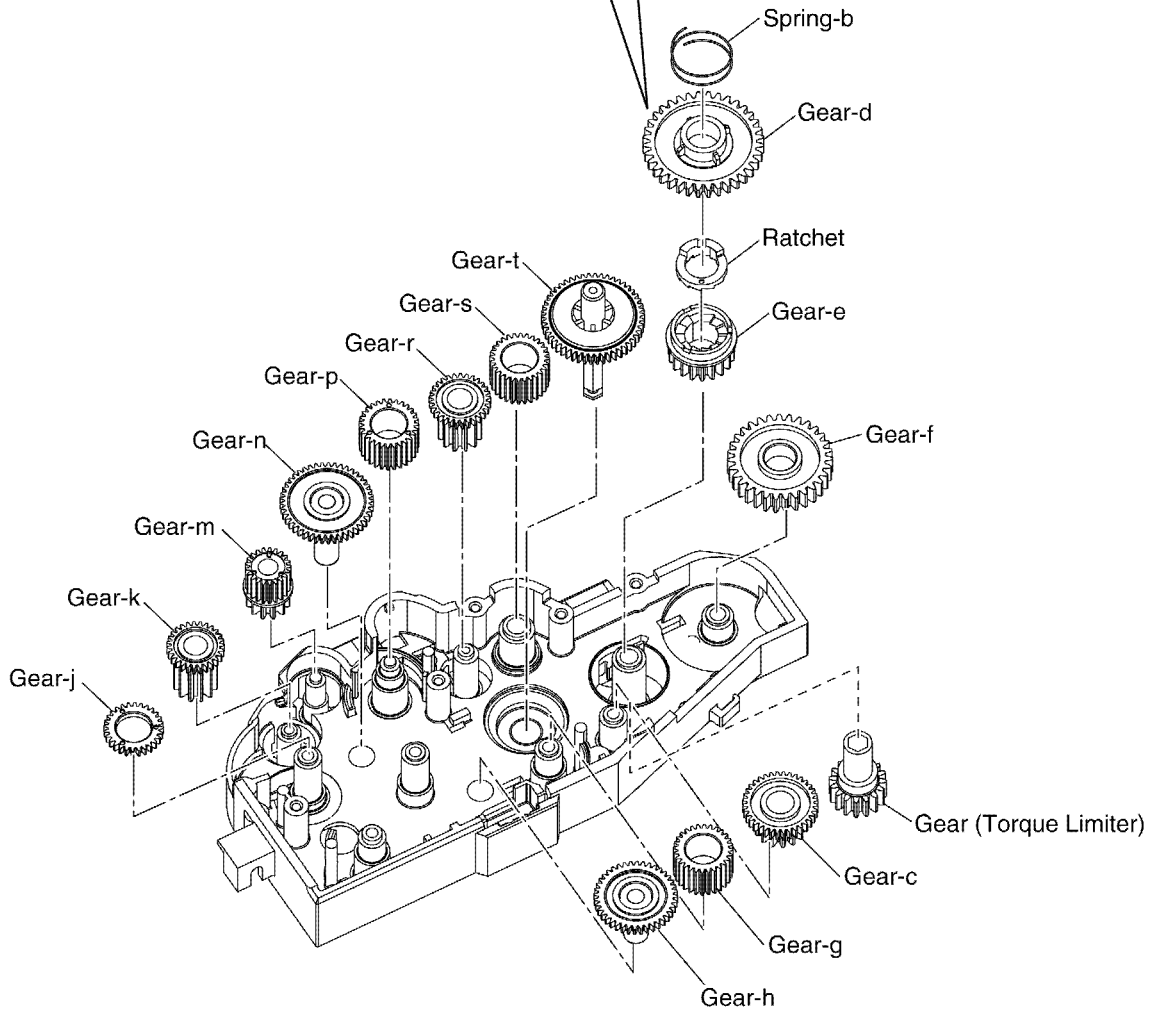
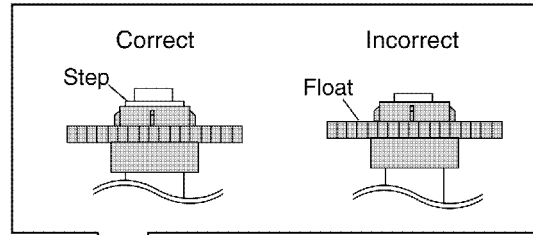

14.3.8. How to Remove the Handset Cradle and Hook Switch Board

PROCEDURE: B-6

Ref. No. B-6

- 1) Remove the 2 screws (F)-a.
- 2) Release the hooks-a (3 points).
- 3) Open the Operation Panel.
- 4) Remove the Handset Cradle Top.
- 5) Release the hook-b and stopper.
- 6) Remove the Hook Switch Board.
- 7) Remove the Connector.
- 8) Remove the 1 screws (F)-b.
- 9) Remove the Handset Cradle Bottom.

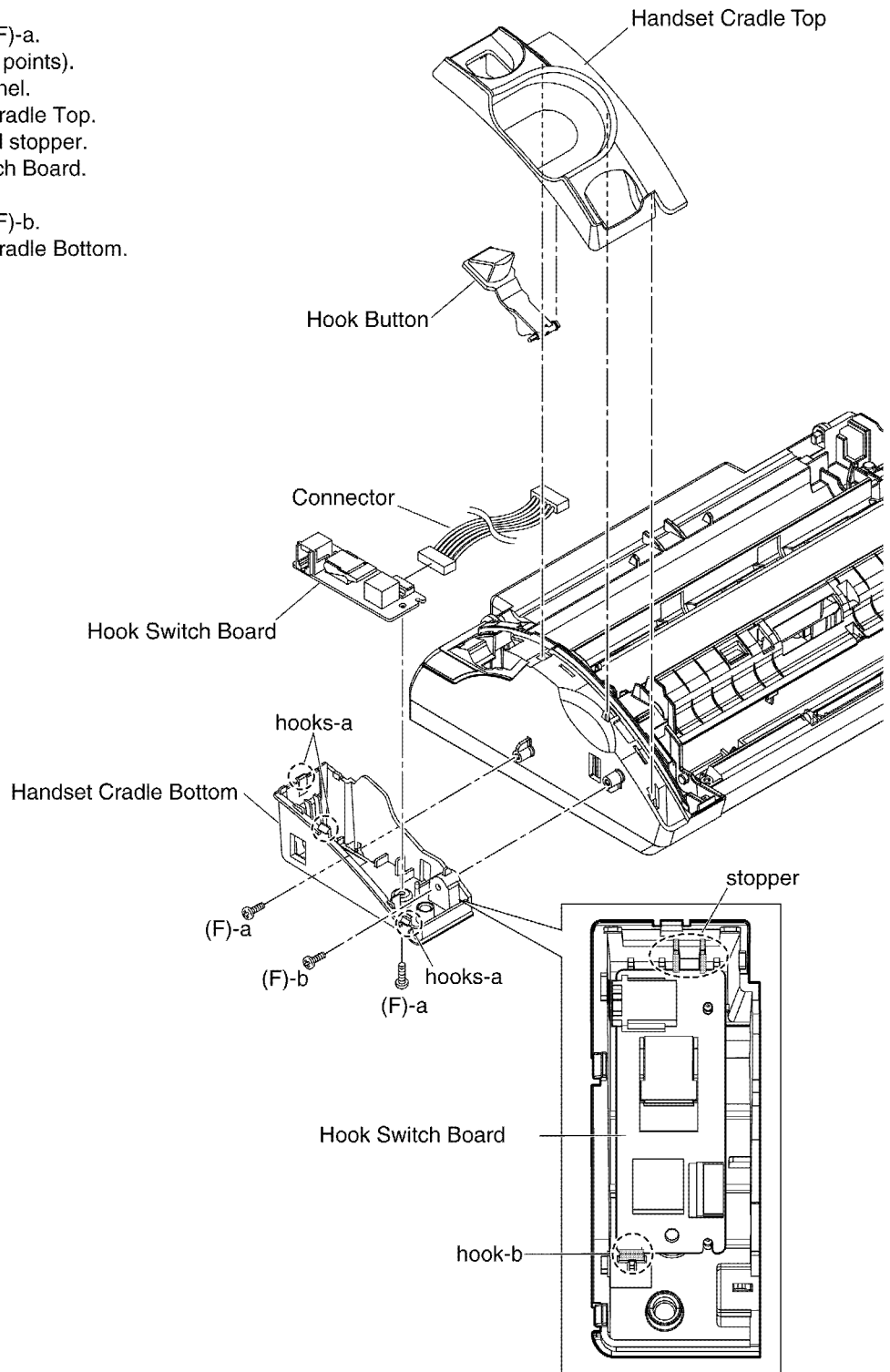

14.3.9. How to Remove the Back Cover

PROCEDURE: C-1

Ref. No. C-1

- 1) Push the Green Button to open the Operation Panel and Back Cover.
- 2) Remove the 1 screw (A).
- 3) Remove the Spring.
- 4) Remove the BACK COVER.

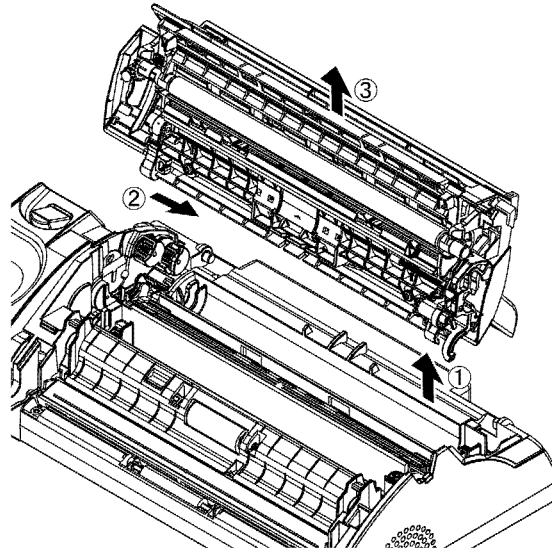
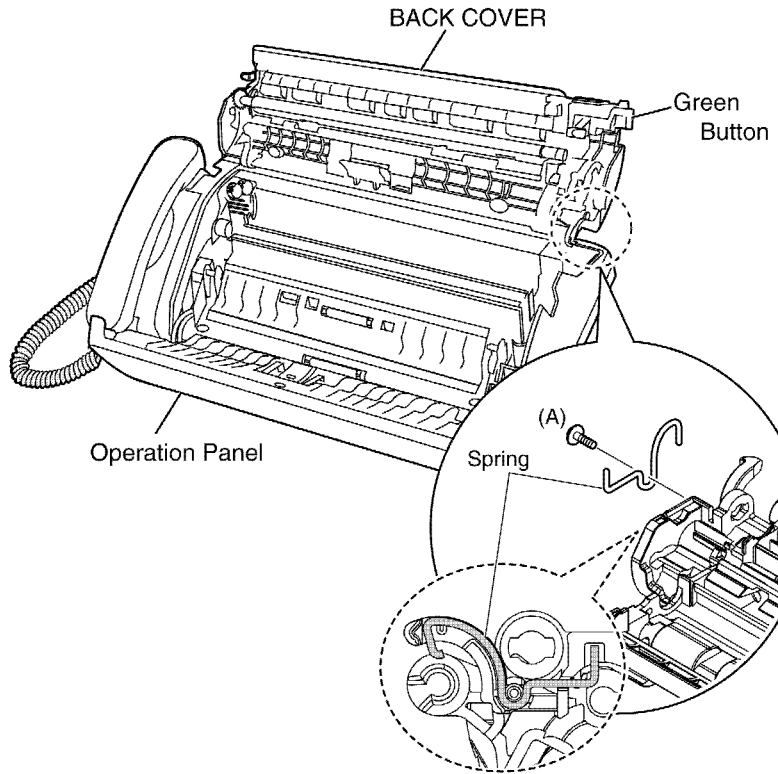

14.3.10. How to Remove the Platen Roller and Lock Lever

PROCEDURE: C-1→C-2

Ref. No. C-2 (1)

- 1) Release the Spacer, as shown in a Fig. L.
- 2) Release the hook of Gear-a, as shown in a Fig. M.
- 3) Remove the Gear-a.
- 4) Remove the PLATEN ROLLER.
- 5) Remove the 2 screws (A).
- 6) Remove the Base Chassis after release the 5 hooks-a.

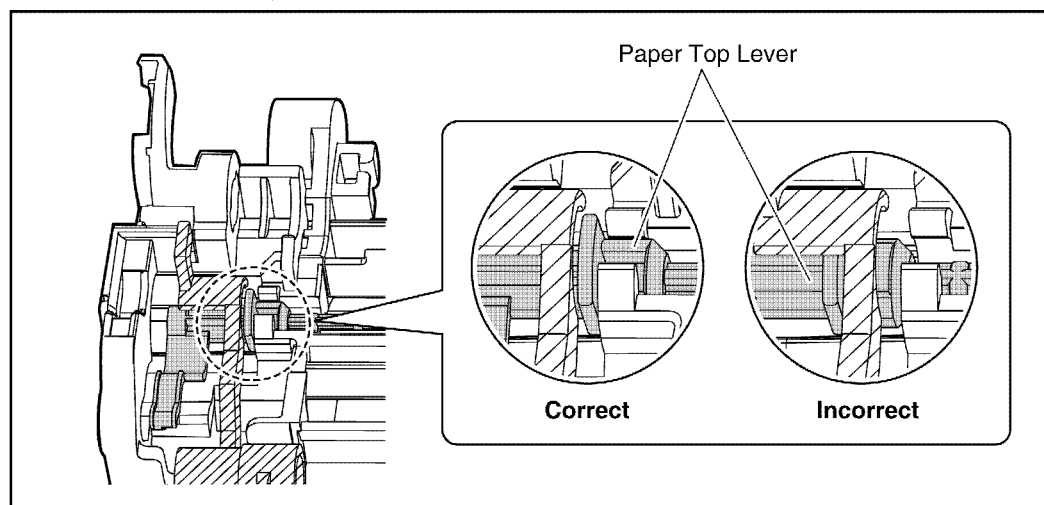
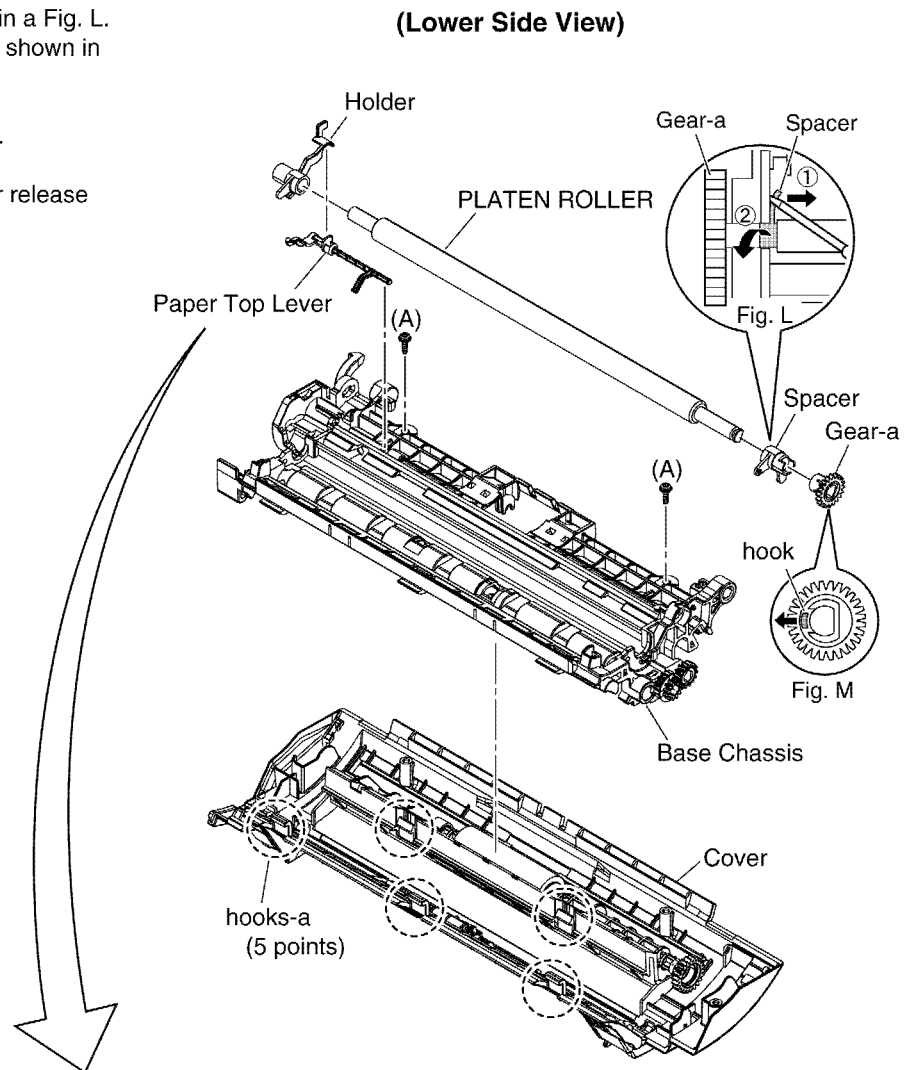

Ref. No. C-2 (2)

- 7) Remove the Spring.
- 8) Remove the LOCK LEVER after release the 2 hooks-b.
- 9) Release the hook of Gear-b, as shown in a Fig. N.
- 10) Remove the Gear-b.
- 11) Remove the Discharge Roller.
- 12) Remove the Paper Separation Holder.

Note for Assembly 1:

- When Base Chassis is inserted in the Cover, be careful of the insertion of Recording paper spring. (See Fig. P)

Note for Assembly 2:
Inserting this side first.

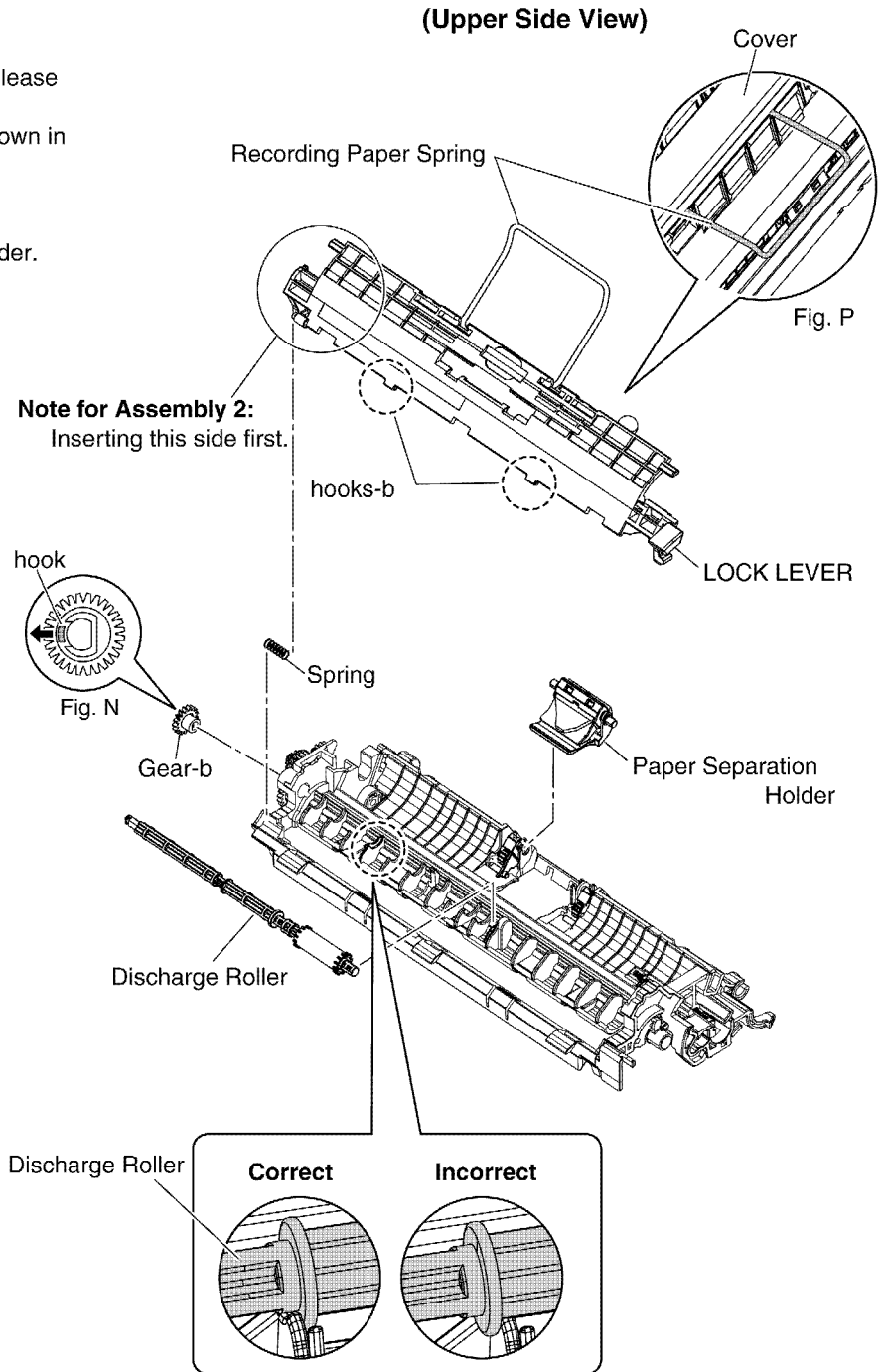

14.3.11. How to Remove the Pickup Roller

PROCEDURE: C-1→C-2→C-3

Ref. No. C-3

PICK UP ROLLER

- 1) Remove the PICK UP ROLLER.

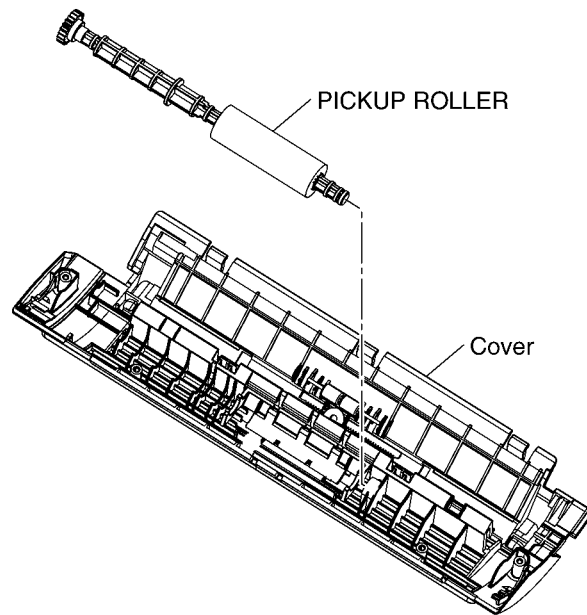

14.3.12. How to Remove the Operation Panel

PROCEDURE: B-1→B-2→D-1

Ref. No. D-1

- 1) Disconnect the Operation lead wire on the Digital Board. (Refer to **B-2**.)
And remove the Core on the Operation lead wire.
- 2) Open the Operation Panel.
- 3) Release the both Arms, as shown in a Fig. Q.
- 4) **Release the Earth Spring from the Main Cabinet certainly.**
- 5) Remove the OPERATION PANEL from Main Cabinet.

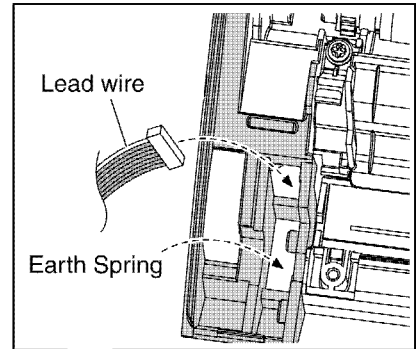
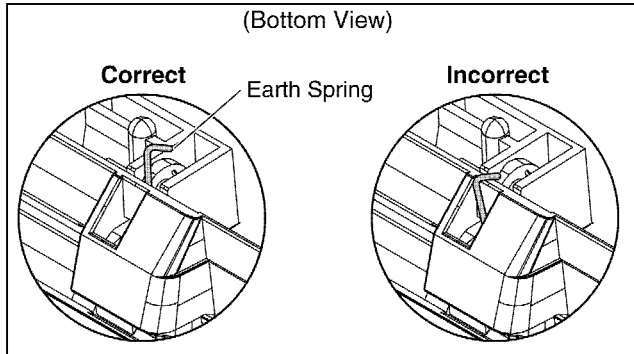

Note for Assembly:
Insert the Lead wire and Earth Spring, as shown in a figure.

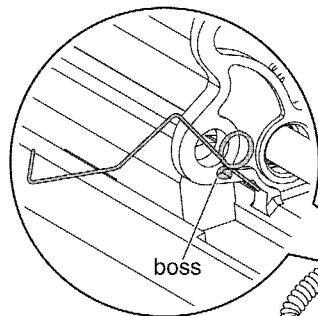

Note for Assembly:
Install the Operation Panel in the Main Cabinet as a Earth Spring hangs on boss.

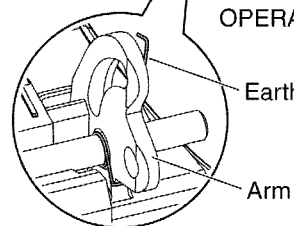

Caution:
Please remove the Operation Panel after releasing Earth Spring from Main Cabinet so that spring may not be deformed.

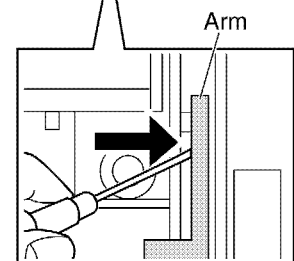
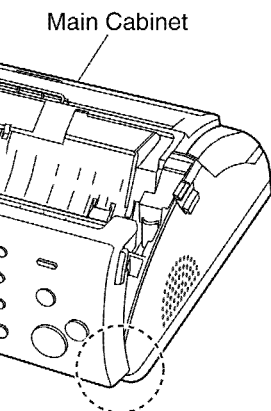

Fig. Q

14.3.13. How to Remove the Operation Board and LCD

14.3.13.1. KX-FP207FX

PROCEDURE: B-1→B-2→D-1→D-2

Ref. No. D-2 This pictured model is KX-FP207.

- 1) Remove the 3 screws (F)-a.
- 2) Release the 2 hooks-a.
- 3) Remove the Cover.
- 4) Release the 5 hooks-b.
- 5) Disconnect the Connector.
- 6) Remove the OPERATION BOARD from Operation Panel.
- 7) Release the 2 hooks-c.
- 8) Remove the LCD from Operation Panel.

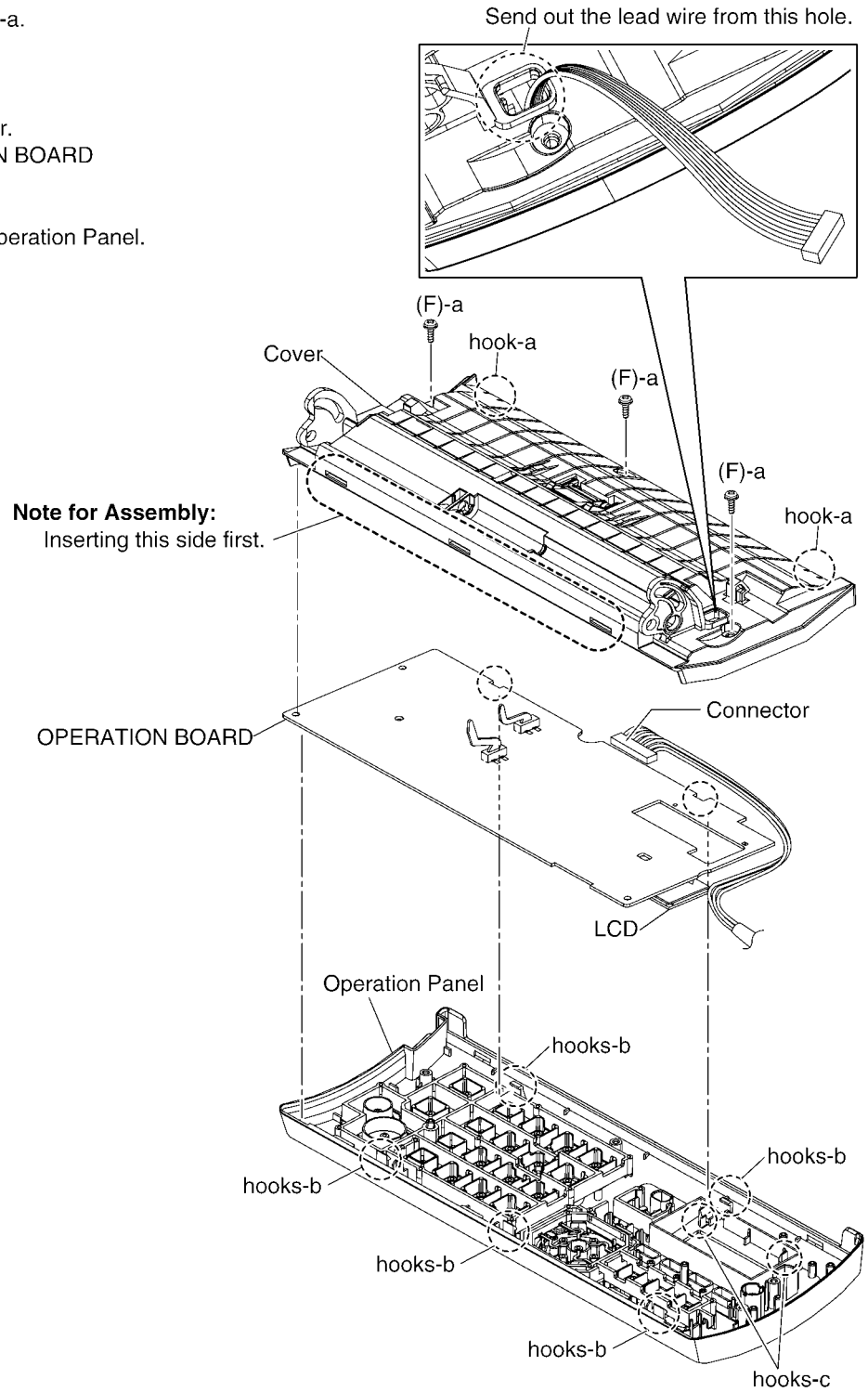

14.3.13.2. KX-FP218FX

PROCEDURE: B-1→B-2→D-1→D-2

Ref. No. D-2 This pictured model is KX-FP218.

- 1) Remove the 3 screws (F)-a.
- 2) Release the 2 hooks-a.
- 3) Remove the Cover.
- 4) Release the 5 hooks-b and the 2 hooks-c.
- 5) Disconnect the Connector.
- 6) Remove the OPERATION BOARD and LCD.
- 7) Remove the 1 screw (F)-b.
- 8) Unsolder the MIC lead wires.
- 9) Remove the MIC BOARD.

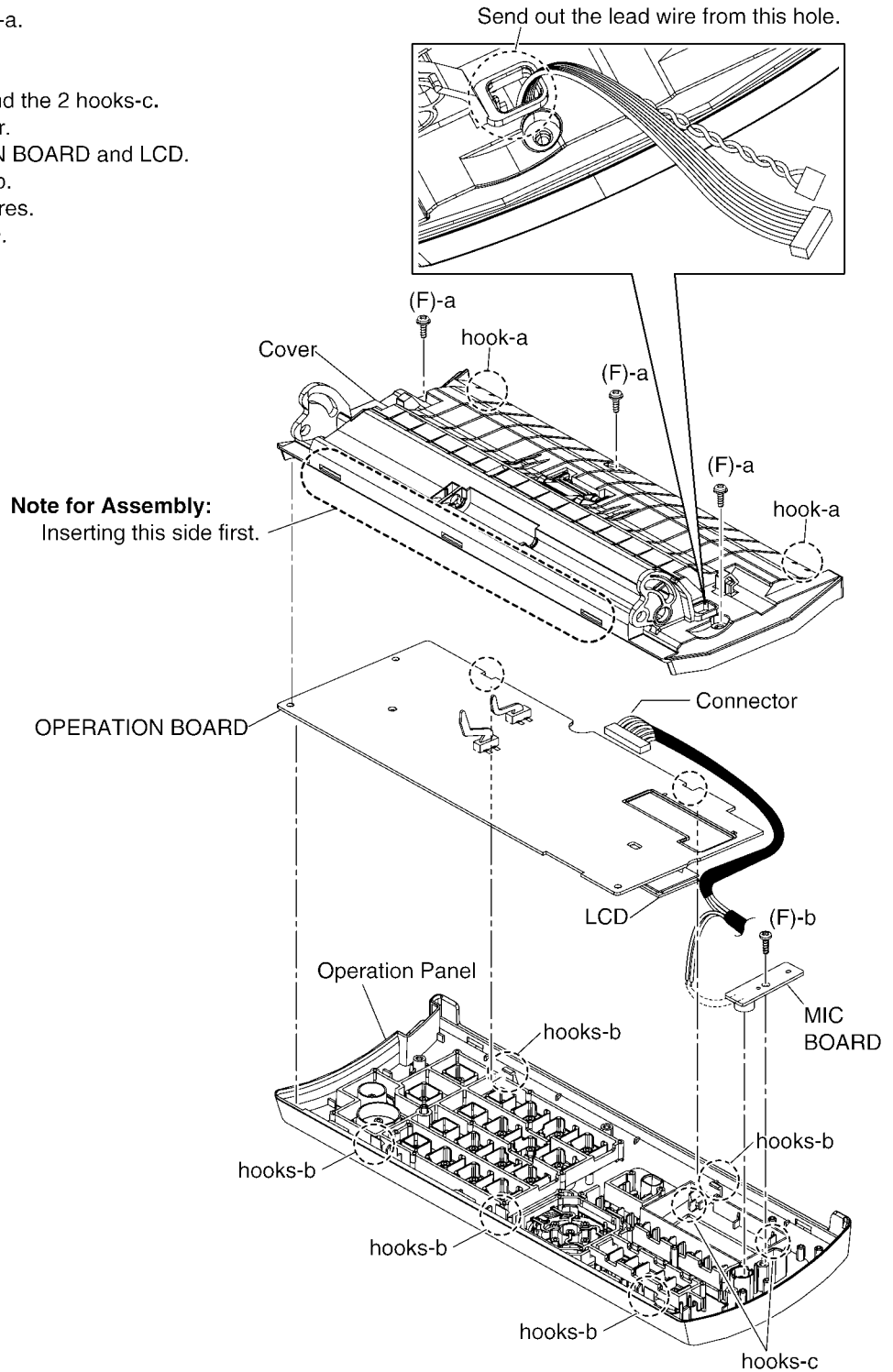

14.3.14. How to Remove the Separation Holder and Exit Roller

PROCEDURE: B-1→B-2→D-1→D-3

Ref. No. D-3

SEPARATION HOLDER

- 1) Release the hook. (See Fig. R)
- 2) Remove the Document Feed Support. (See Fig. R)
- 3) Remove the SEPARATION HOLDER.

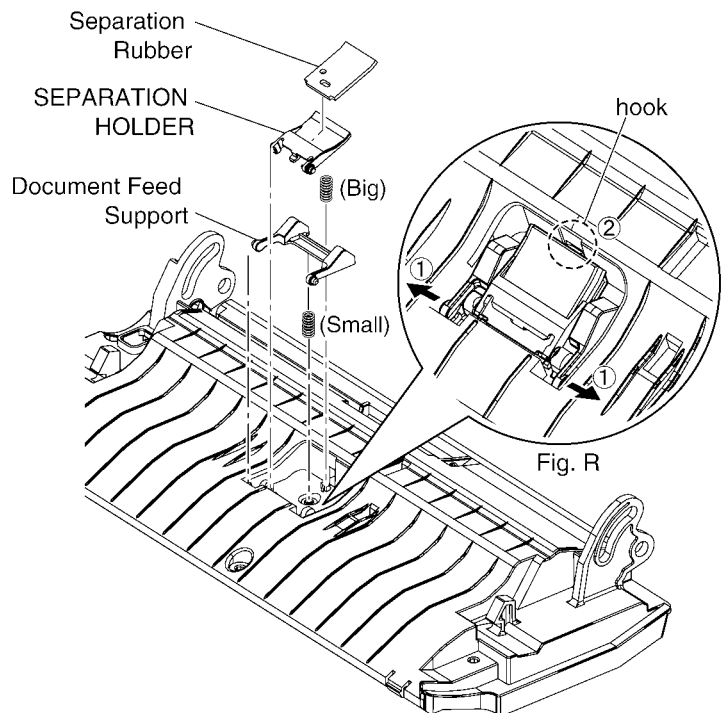

EXIT ROLLER

- 1) Pull out the Gear from Exit Roller.
- 2) Remove the EXIT ROLLER.

Caution:

Be careful not to deform the Earth Spring.

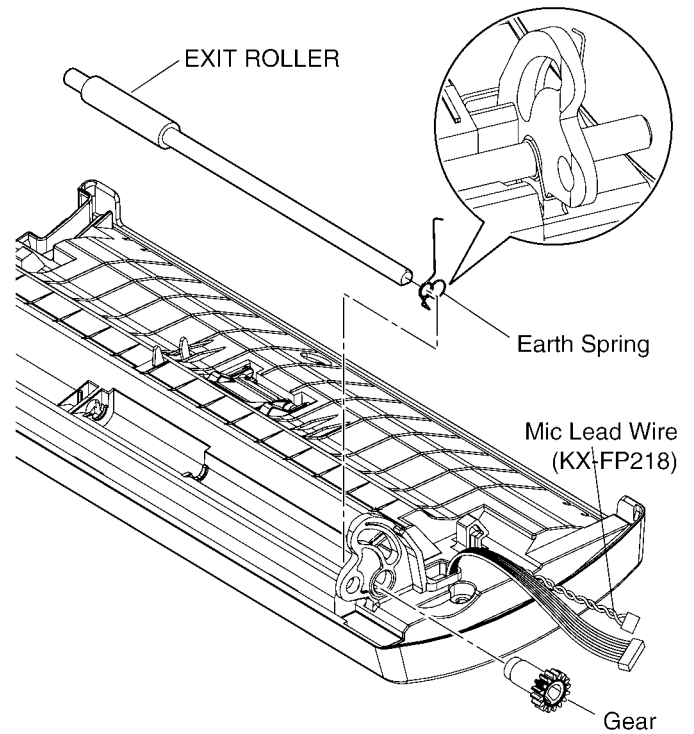

14.3.15. Installation Position of the Lead Wires

14.3.15.1. Lower Section

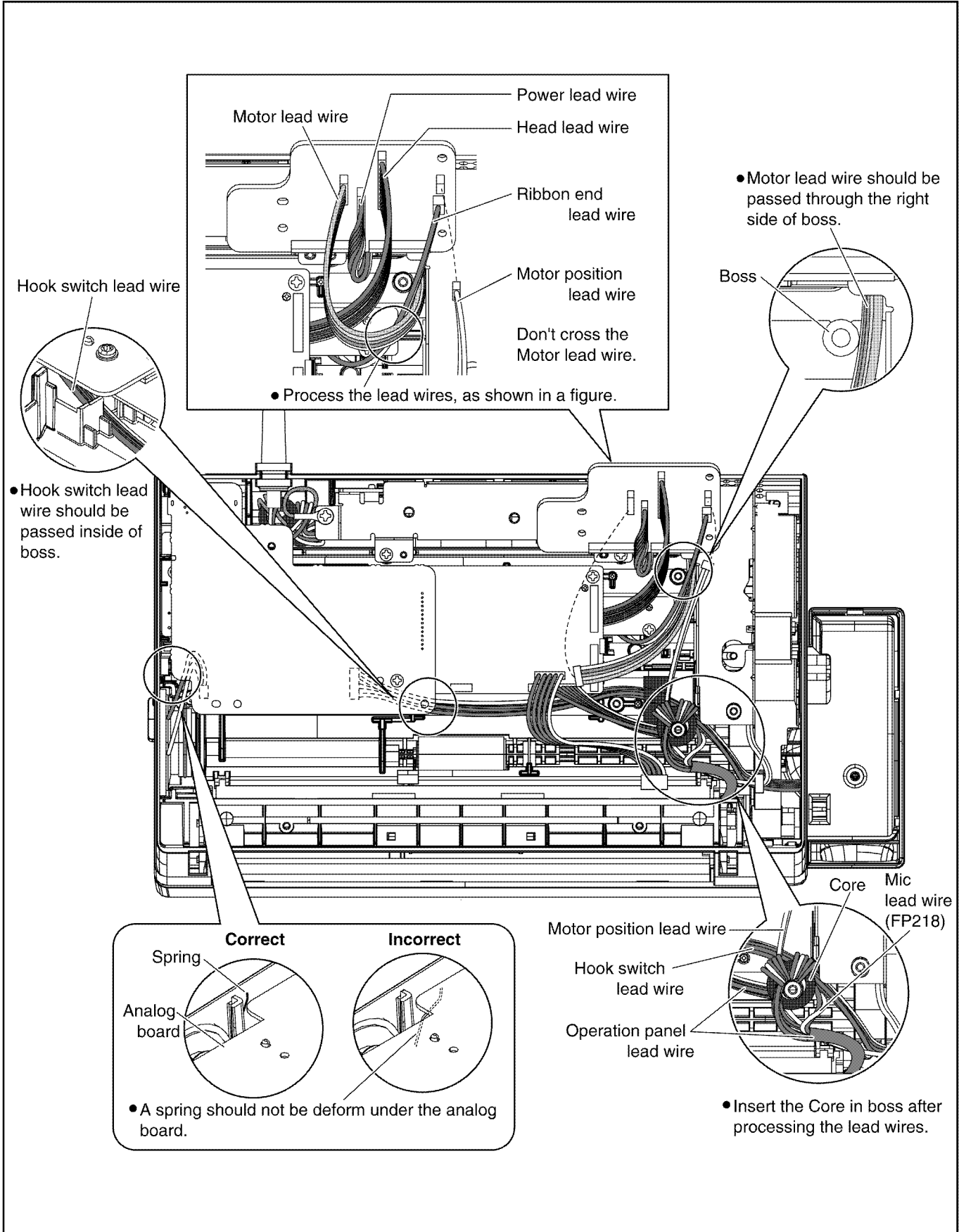

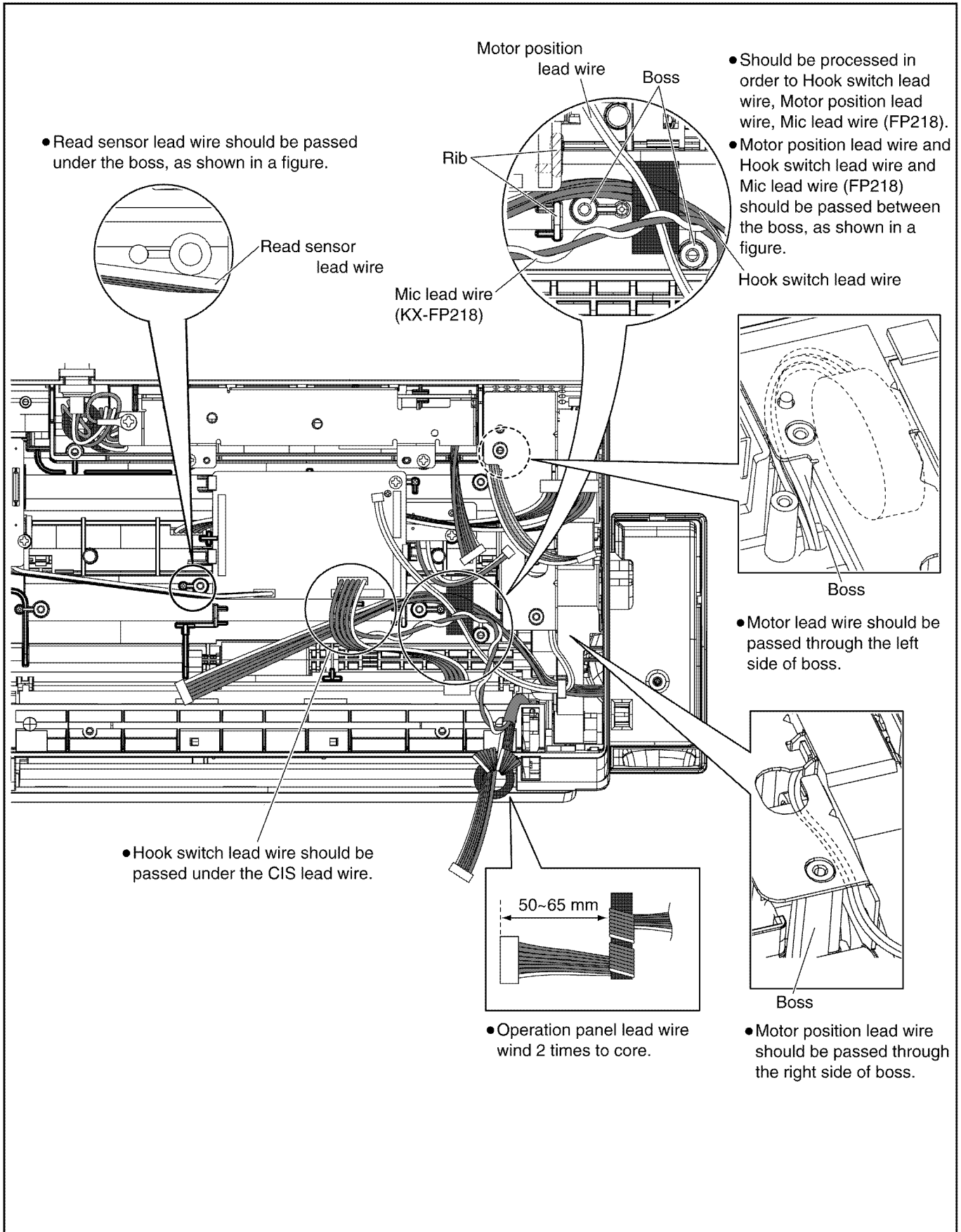

• Head lead wire should be passed between the rib.

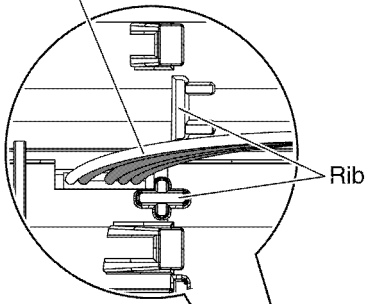

• Power lead wire should be passed through the notch part.

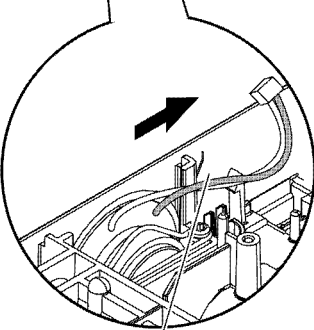
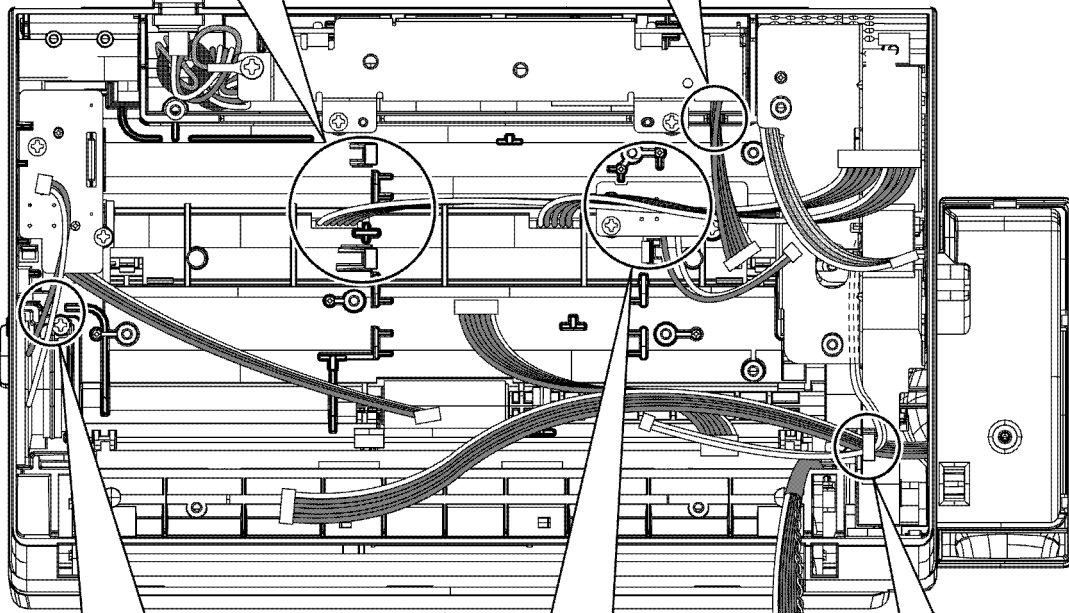
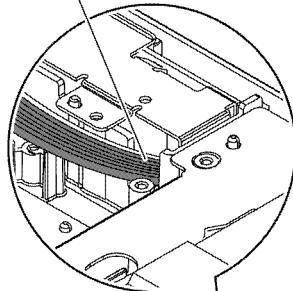

• Push the Speaker lead wire into the direction of the arrow when installing in the Analog board.

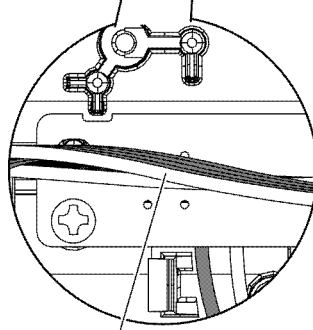

• Head lead wire should be passed on the Film end sensor board.

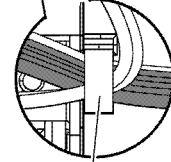

• Hang the Motor position lead wire and Hook switch lead wire on rib, as shown in a figure.

14.3.15.2. Operation Panel Section (KX-FP207)

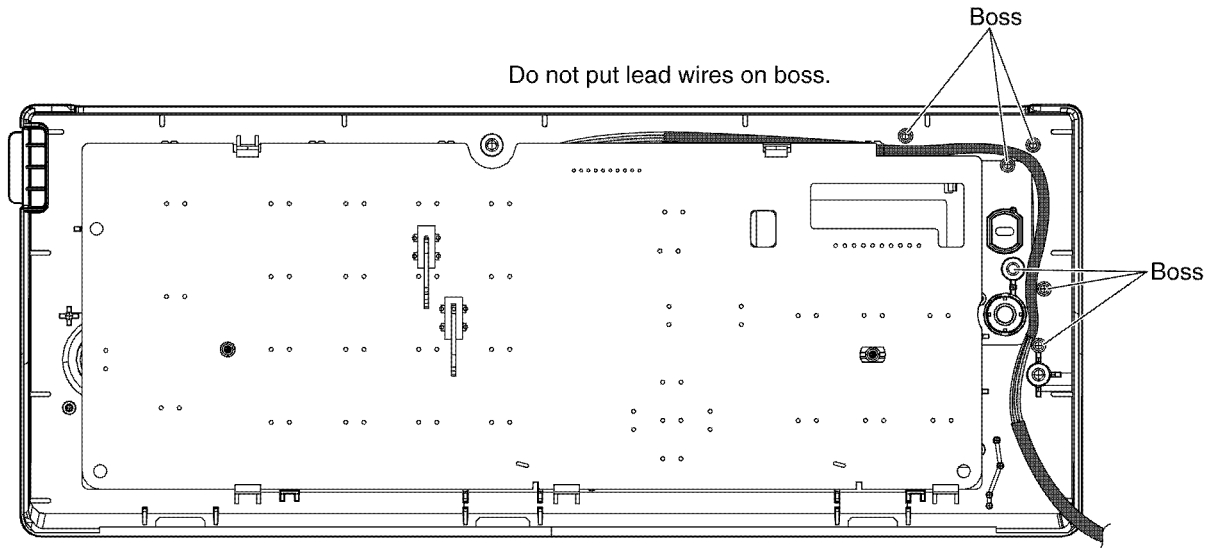

14.3.15.3. Operation Panel and Mic Board Section (KX-FP218)

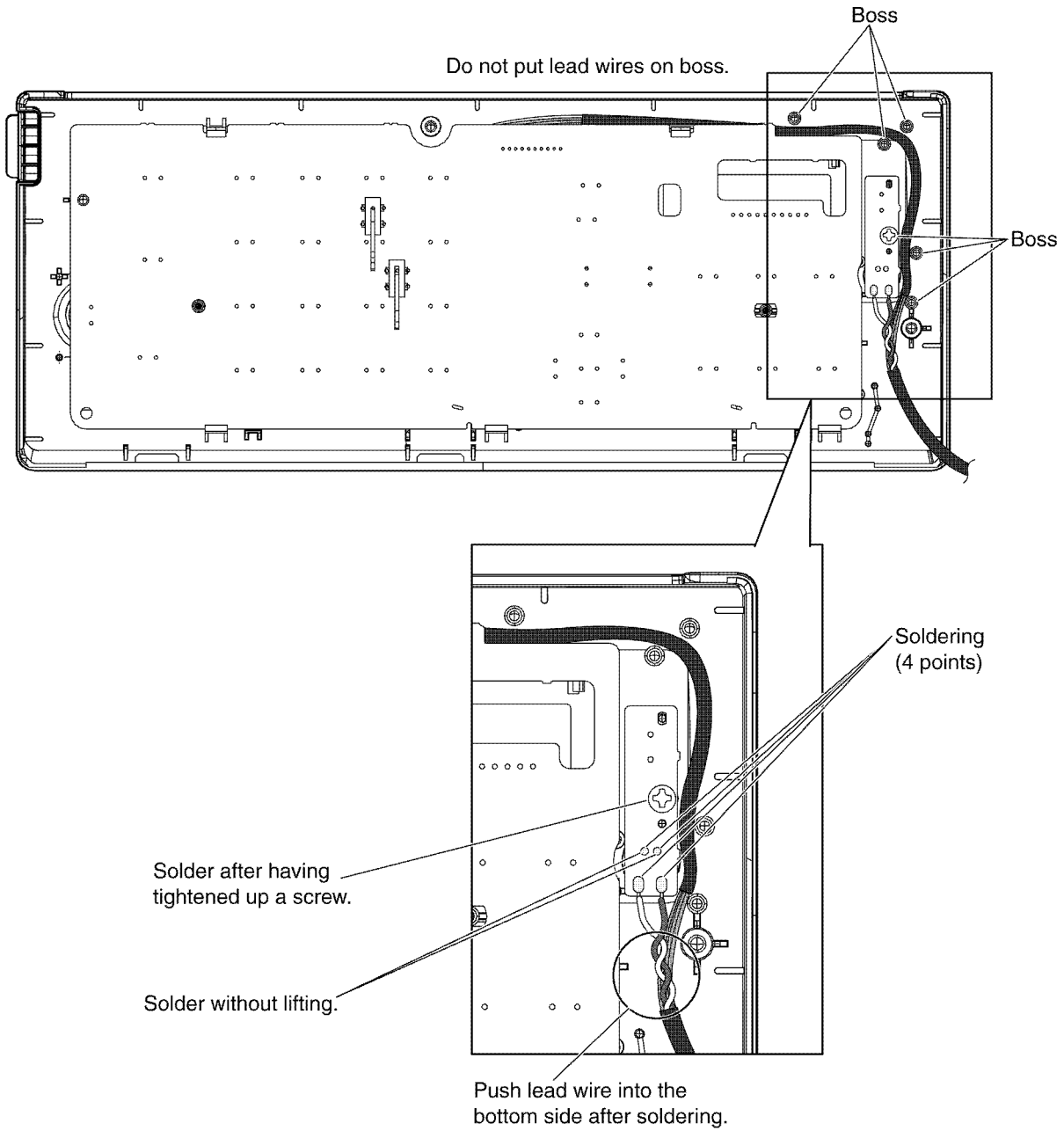

15 Maintenance

15.1. Maintenance Items and Component Locations

15.1.1. Outline

Maintenance and repairs are reformed using the following steps.

1. Periodic maintenance

Inspect the equipment periodically and if necessary, clean any contaminated parts.

2. Check for breakdowns

Look for problems and consider how they arose.

If the equipment can be still used, perform copying, self testing or communication testing.

3. Check equipment

Perform copying, self testing and communication testing to determine if the problem originates from the transmitter, receiver or the telephone line.

4. Determine causes

Determine the causes of the equipment problem by trouble-shooting.

5. Equipment repairs

Repair or replace the defective parts and take appropriate measures at this stage to ensure that the problem will not recur

6. Confirm normal operation of the equipment

After completing the repairs, conduct copying, self testing and communication testing to confirm that the equipment operates normally.

7. Record keeping

Make a record of the measures taken to rectify the problem for future reference.

15.1.2. Maintenance Check Items/Component Locations

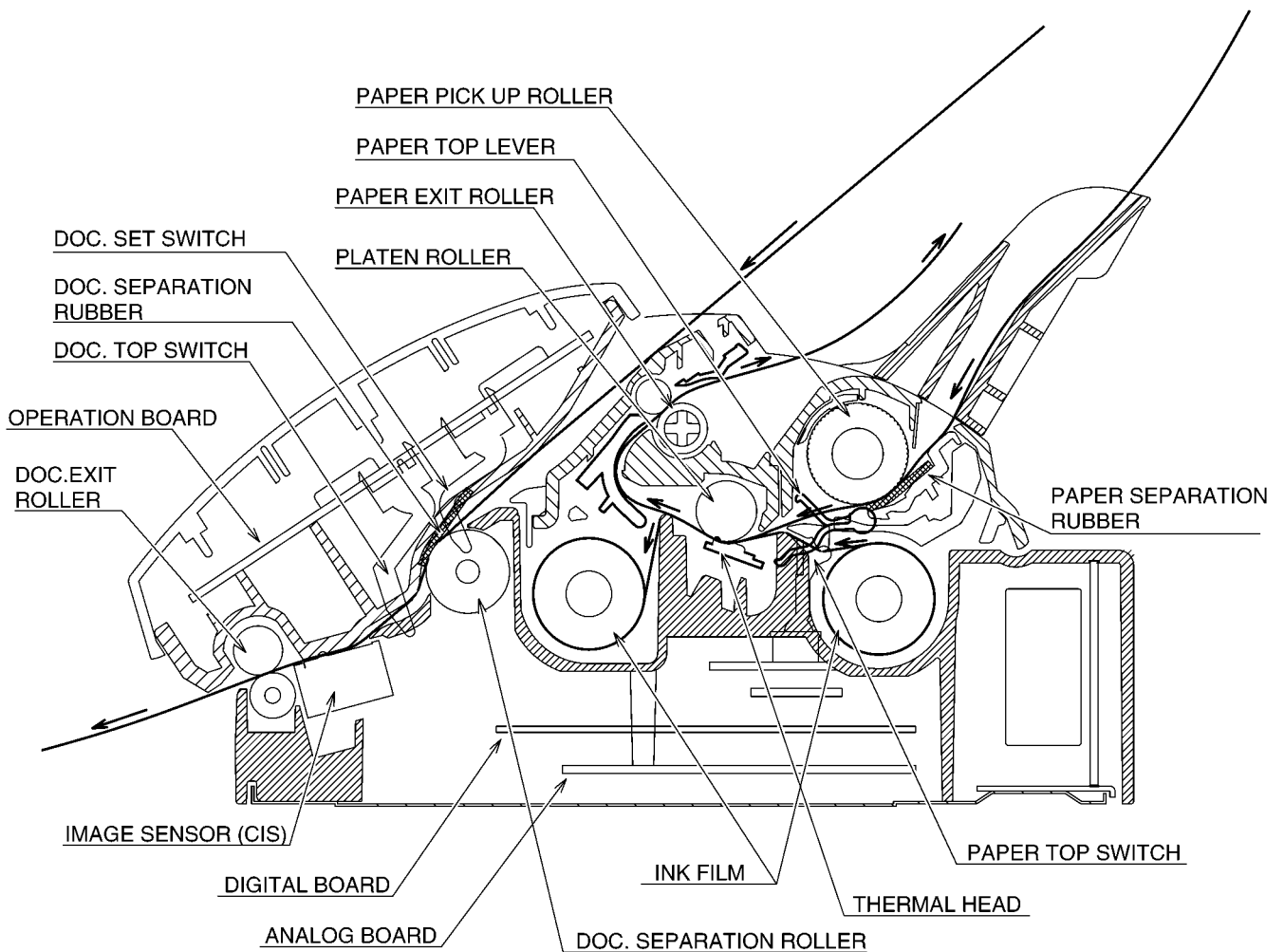

15.1.2.1. Maintenance List

No.	OPERATION	CHECK	REMARKS
1	Document Path	Remove any foreign matter such as paper.	—
2	Rollers	If the roller is dirty, clean it with a damp cloth then dry thoroughly.	Refer to Document feeder/recording paper feeder/scanner glass cleaning (P.174).
3	Platen Roller	If the platen is dirty, clean it with a damp cloth then dry thoroughly. Remove the paper and film cartridge before cleaning.	—
4	Thermal Head	If the thermal head is dirty, clean the printing surface with a cloth moistened with denatured alcohol (alcohol without water), then dry thoroughly.	Refer to Thermal Head Cleaning (P.175).
5	Sensors	Document top sensor (SW351), Document set sensor (SW352), Cover open sensor (SW1001), Paper top sensor (SW1001), Film detection sensor (SW1002), Film end sensor (SW1003) . Confirm the operation of the sensors.	See Maintenance Check Items/Component Locations (P.163) and How to Remove the P.C. Boards and Speaker (P.144).
6	Glass	If the glass is dirty, clean them with a dry soft cloth.	Refer to Document feeder/recording paper feeder/scanner glass cleaning (P.174).
7	Abnormal, wear and tear or loose parts	Replace the part. Check if the screws are tight on all parts.	—

15.1.2.2. Maintenance Cycle

No.	Item	Cleaning Cycle	Replacement	
			Cycle	Procedure
1	Separation Roller (Ref. No. 145)*2	3 months	7 years*1 (31,500 documents)	Refer to How to Remove the Gear Block and Separation Roller (P.146).
2	Separation Rubber (Ref. No. 13)	3 months	7 years (31,500 documents)	Refer to Document feeder/recording paper feeder/scanner glass cleaning (P.174).
3	Feed Rollers (Ref. No. 11, 56, 94)	3 months	7 years (31,500 documents)	Refer to Disassembly and Assembly Instructions (P.137).
4	Thermal Head (Ref. No. 40)	3 months	7 years (31,500 documents)	Refer to How to Remove the Thermal Head (P.141).
5	Platen Roller (Ref. No. 90)	3 months	7 years (31,500 documents)	Refer to How to Remove the Platen Roller and Lock Lever (P.151).
6	Pickup Roller (Ref. No. 96)	3 months	7 years (31,500 documents)	Refer to How to Remove the Pickup Roller (P.153).

Note:

*1 These values are standard and may vary depending on usage conditions.

*2 Refer to **Cabinet, Mechanical and Electrical Parts Location** (P.211).

15.2. Gear Section

This model provides a motor-driven gear mechanism for transmitting/copying documents and printing fax data. In this chapter, you will see how the gears work to select and operate a mode and how the gear section, sensors and rollers mechanically work during the main operations (FAX transmission, FAX reception and Copy).

15.2.1. Mode Selection

When a motor with Drive Motor Gear attached rotates clockwise (CW), Swing Gear E engages CAM Gear to rotate clockwise (CW). This operation provide five mode options (**A**: Transmit mode, **B**: Paper-Pickup mode, **C**: Assist mode **D**: Receive mode and **E**: Copy mode) selected by the Sensor Switch. (The Sensor Switch Lever's position in the CAM Gear controlled by the software selects a specific mode.) You can see which mode is selected by confirming the Mode Marker's position as shown in Fig. 1.

(Ex. If the Mode Marker is in position **A**, a transmit mode is selected.)

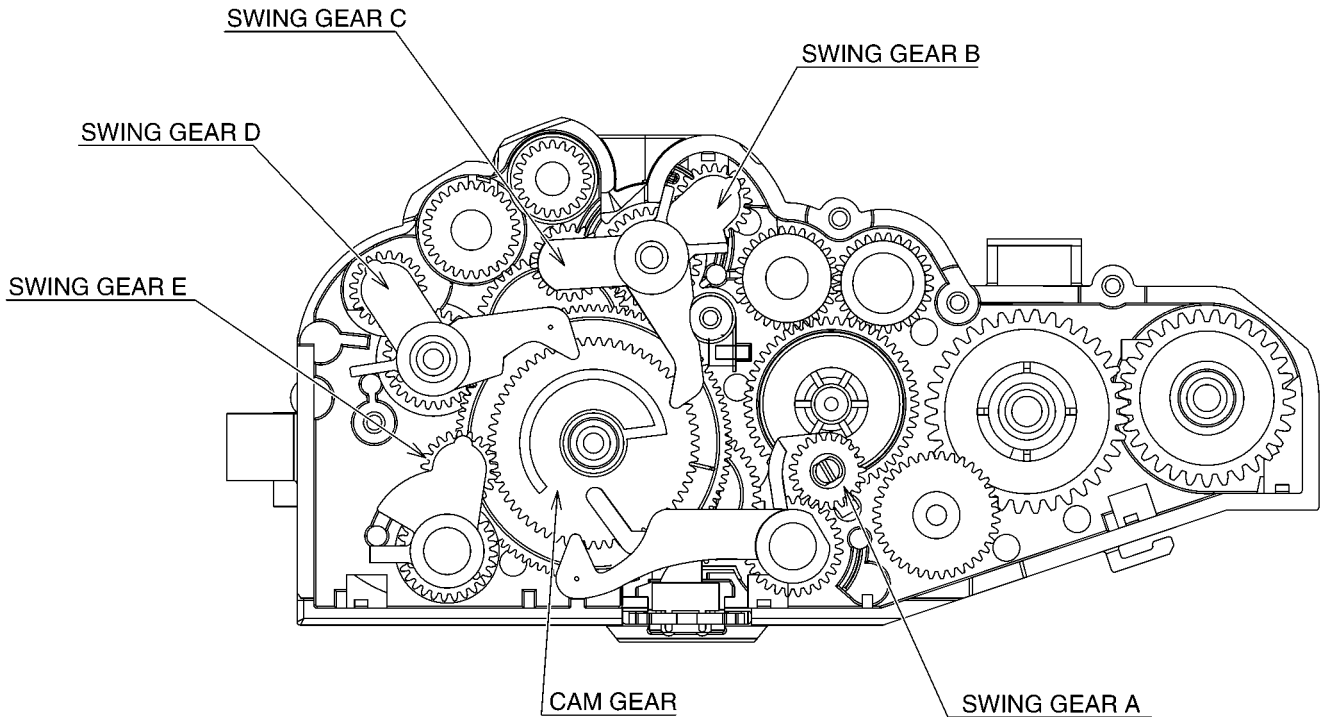

15.2.2. Mode Operation

Once a mode is selected, the Drive Motor Gear rotates counterclockwise (CCW) and then the controlling positions of Swing Gears A, B and C, D, E determine which gears convey their drive power in each mode. See "Sensor Location" in **Sensors and Switches** (P.29).

A. Transmit mode (See Fig. A.):

The Swing Gear A engages with the next gear to drive Document Separation Roller and Document Exit Roller.
The Swing Gear C engages with the next gear to drive Paper Exit Roller.

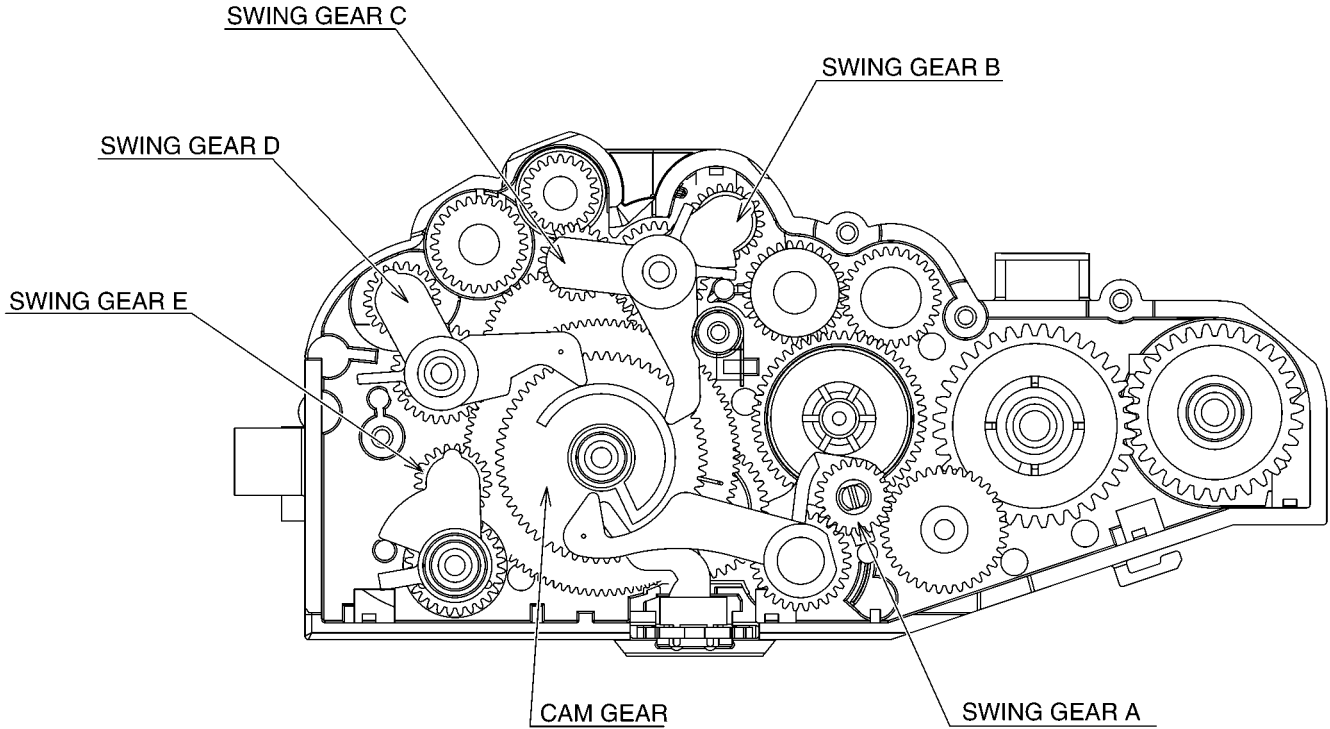

Fig. A: Transmit mode

B. Paper-Pickup mode (See Fig. B):

The Swing Gear C engages with the next gear to drive Paper Exit Roller.
The Swing Gear D engages with the next gear to drive Pickup Roller.

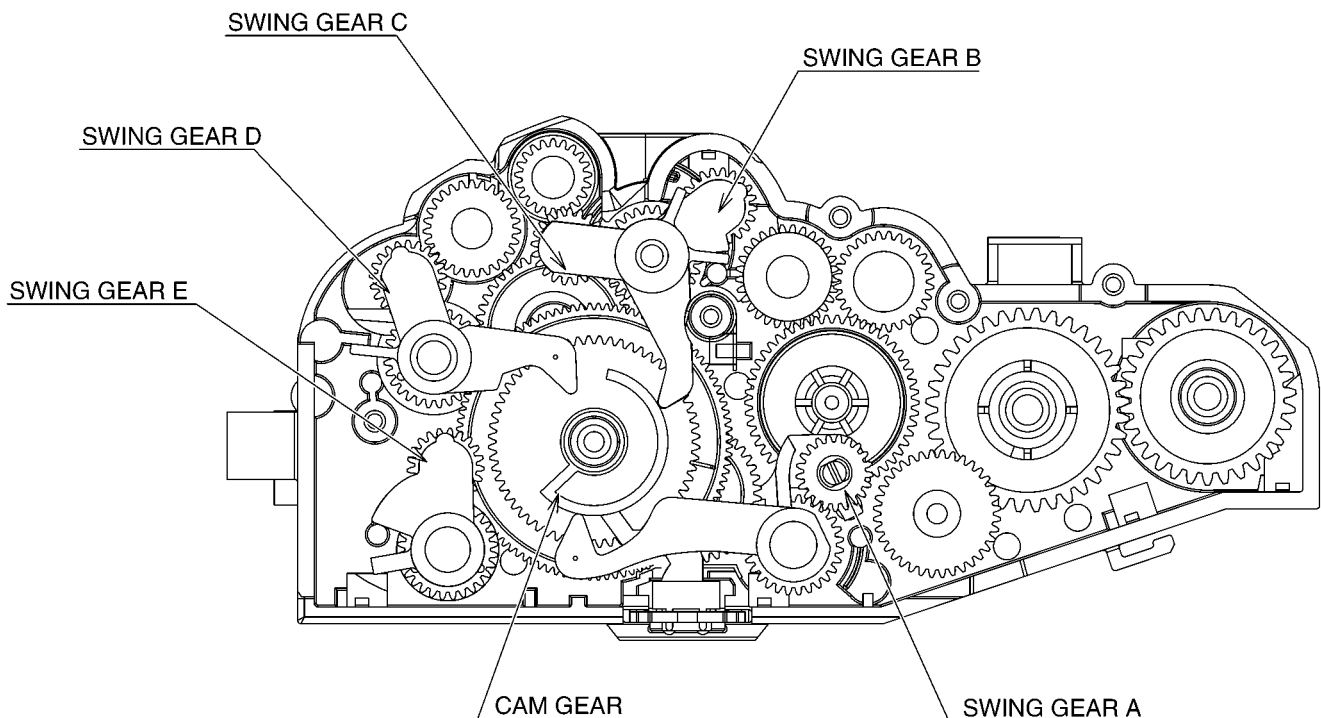

Fig. B: Paper-Pickup mode

C. Assist mode (See Fig. C.):

The Swing Gear D engages with the next gear to drive Pickup Roller.

The Swing Gear B engages with the next gear to drive Platen Roller gear and Ribbon Drive Gear.

The Swing Gear C engages with the next gear to drive Paper Exit Roller Gear.

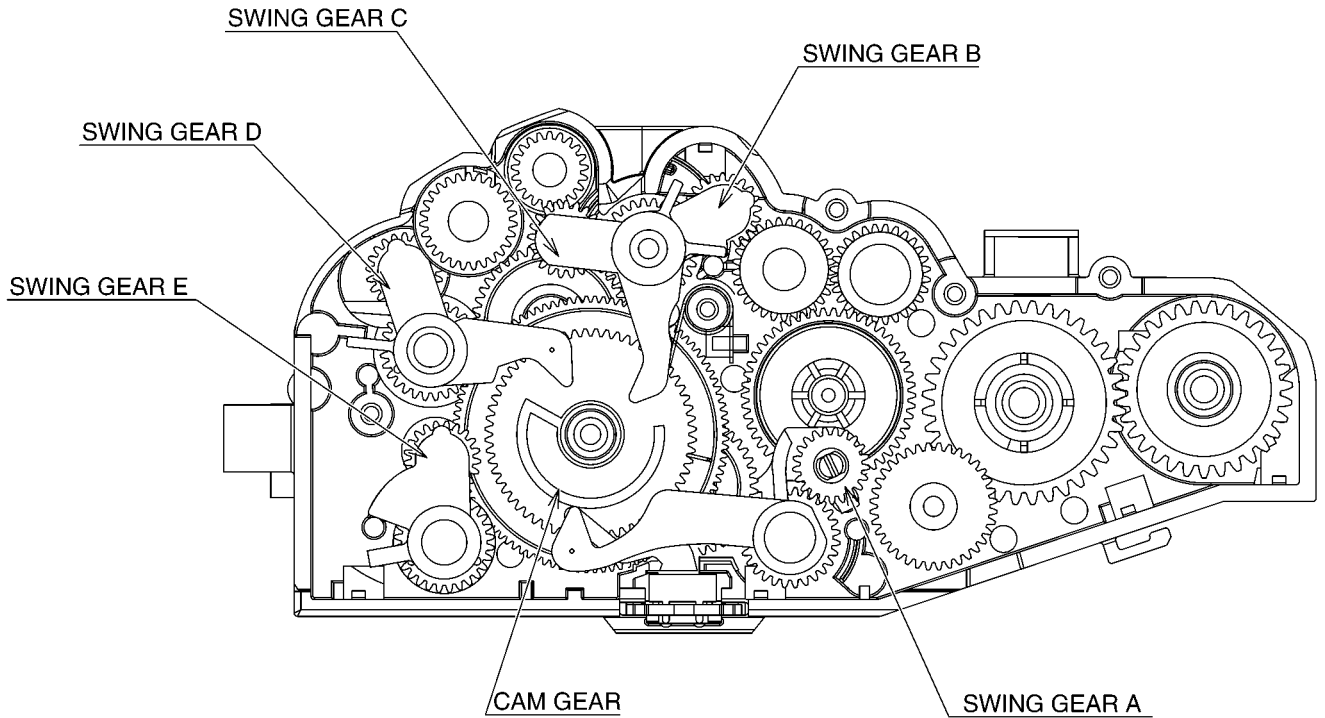

Fig. C: Assist mode

D. Receive mode (See Fig. D.):

The Swing Gear B engages with the next gear to drive Platen Roller gear and Ribbon Drive Gear.

The Swing Gear C engages with the next gear to drive Paper Exit Roller Gear.

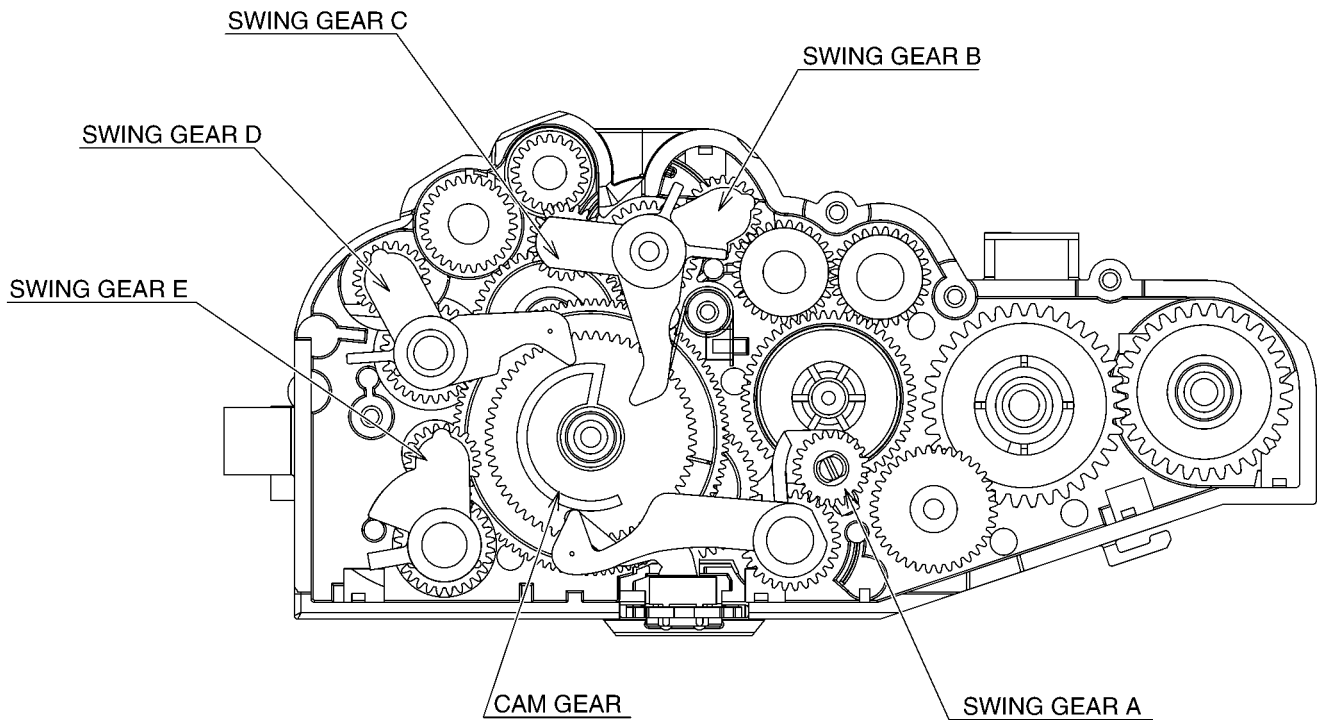

Fig. D: Receive mode

E. Copy mode (See Fig. E.):

“Copy mode” = “Transmit mode” + “Receive mode”

The Swing Gear A engages with the next gear to drive Document Separation Roller and Document Exit Roller.

The Swing Gear B engages with the next gear to drive Platen Roller gear and Ribbon Drive Gear.

The Swing Gear C engages with the next gear to drive Paper Exit Roller.

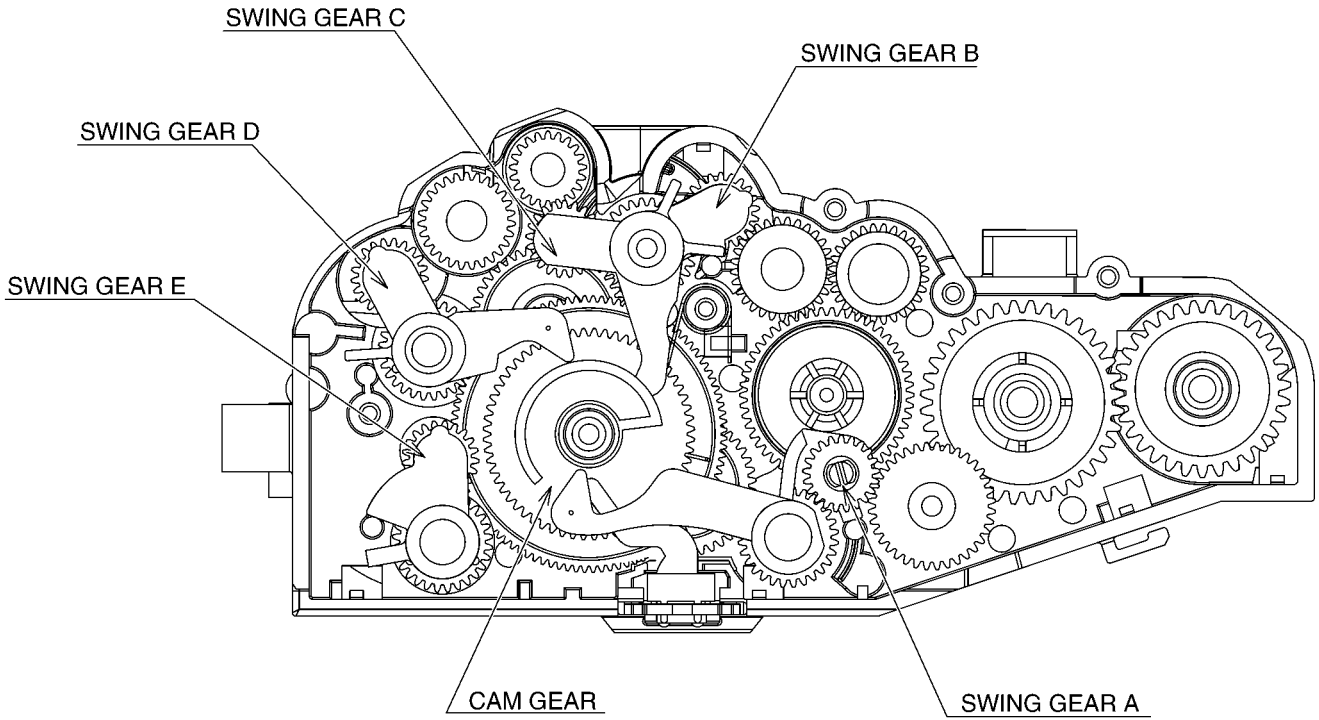
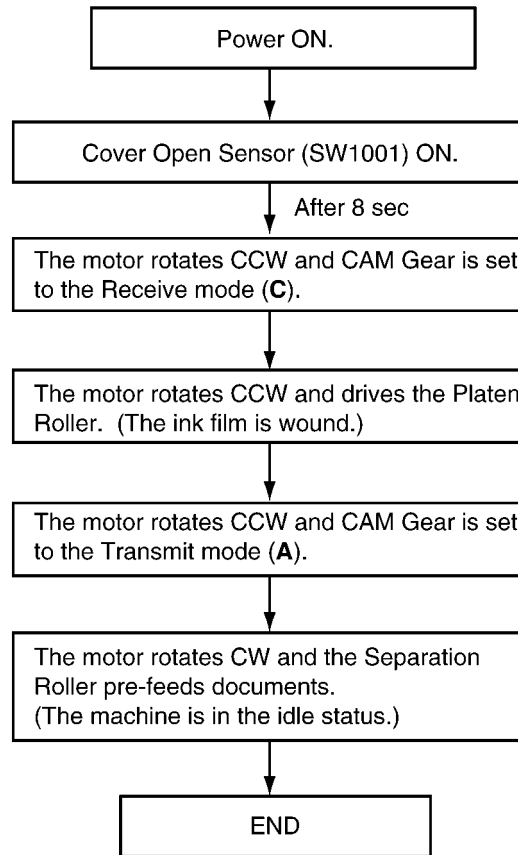

Fig. E: Copy mode

15.2.3. Mechanical Movements in the Main Operations (transmitting documents, receiving faxes and copying)

15.2.3.1. Idle Status



Note:

- See “**Sensor Locations**” in **Sensors and Switches** (P.29).
- CW.....clockwise
- CCW....counterclockwise

15.2.3.2. Transmitting Documents

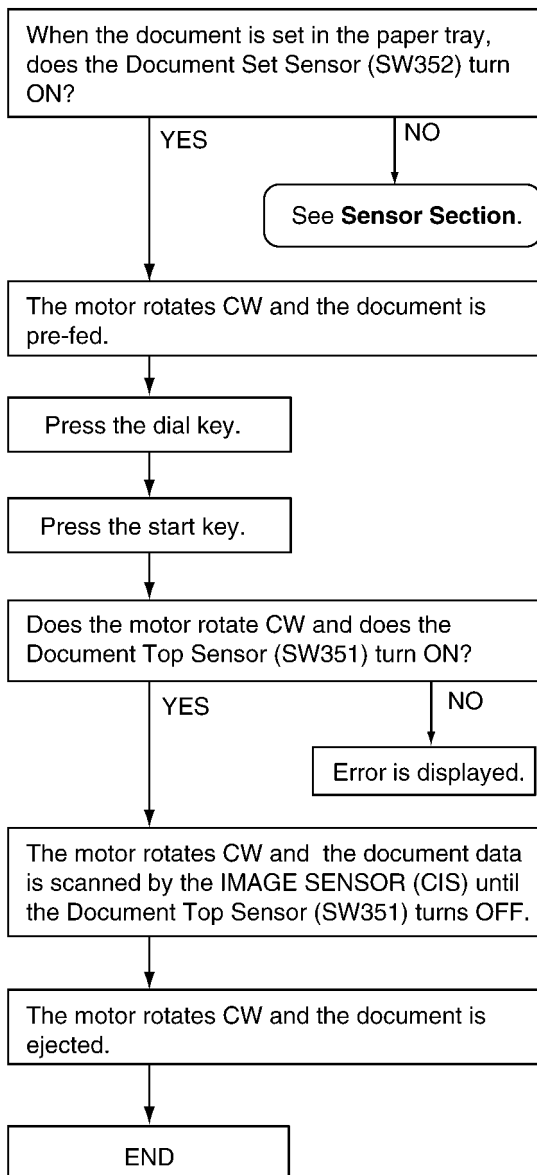

REFERENCE:
Sensor Section (P.132).

15.2.3.3. Receiving Fax

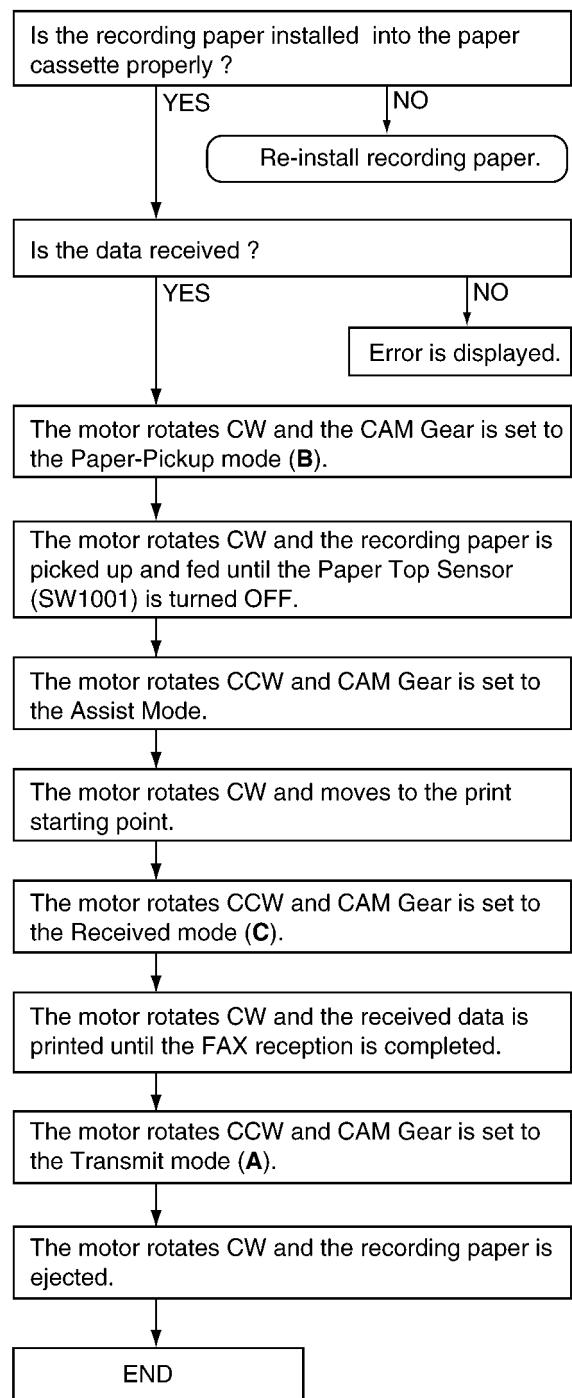

Note:
See "Sensor Locations" in Sensors and Switches (P.29).

15.2.3.4. Copying

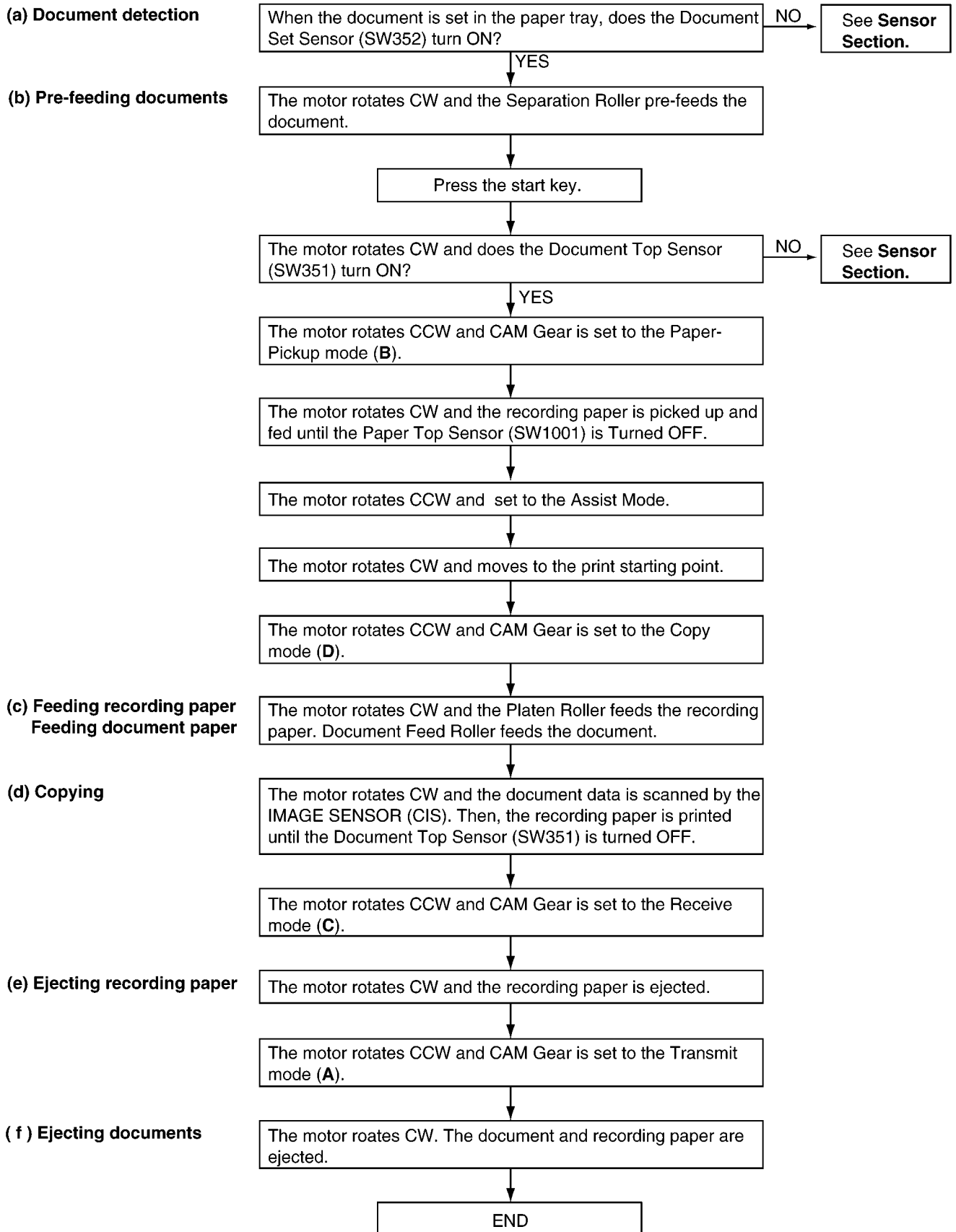

Note:

See "Sensor Locations" in **Sensors and Switches (P.29).**

REFERENCE:

Sensor Section (P.132)

15.3. Jams

15.3.1. Recording Paper Jams

15.3.1.1. When the recording paper has jammed in the unit

The display will show the following.

PAPER JAMMED

Important:

- Remove the recording paper, then remove the paper tray beforehand, otherwise the paper may misfeed or jam.

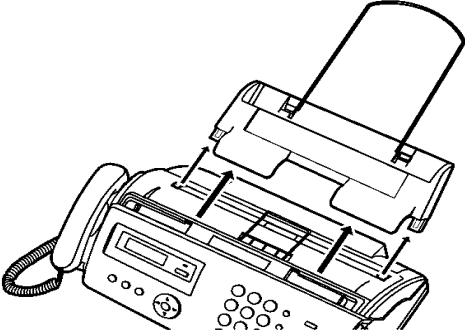

1. Open the front cover (①), push the green button (②), then open the back cover (③).

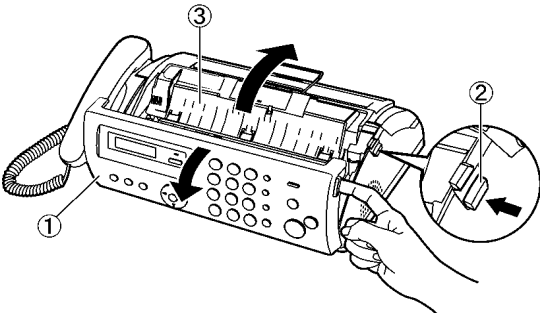

2. Remove the jammed recording paper (④).

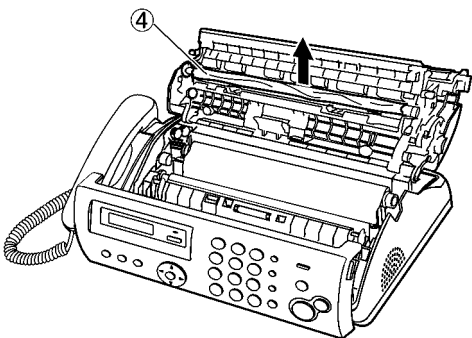

3. Turn the blue gear (⑤) in the direction of the arrow until the ink film is tight (⑥) and at least one layer of ink film is wrapped around the blue core (⑦).

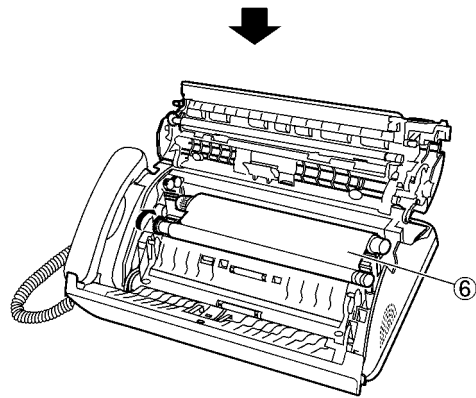
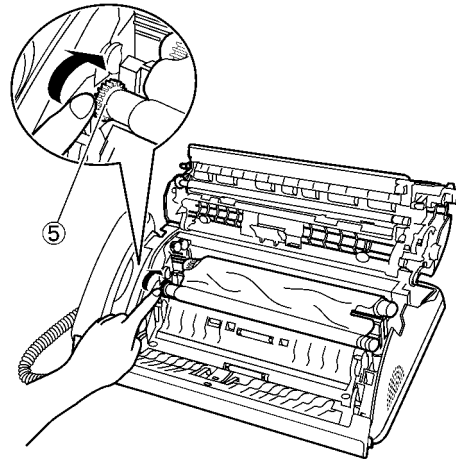

Correct

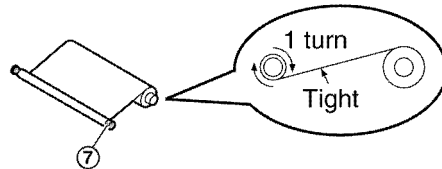

Incorrect

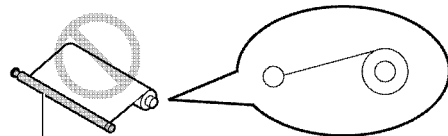

No ink film is wrapped around the blue core.

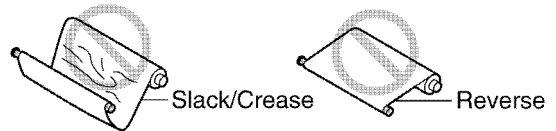

4. Close the back cover securely by pushing down on the dotted area at both ends (⑧), then close the front cover securely (⑨).

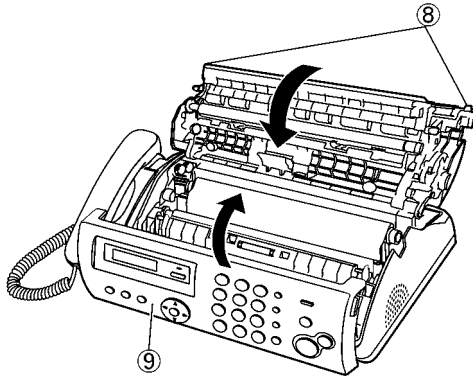

5. Install the paper tray, then insert the recording paper gently.
(See **Installing the Paper Tray** (P.54) and **Installing the Recording Paper** (P.55))

15.3.1.2. When the recording paper was not fed into the unit properly

The display will show the following.

CHECK PAPER

Remove the recording paper and straighten. Insert the paper, then press **[SET]** to clear the message.

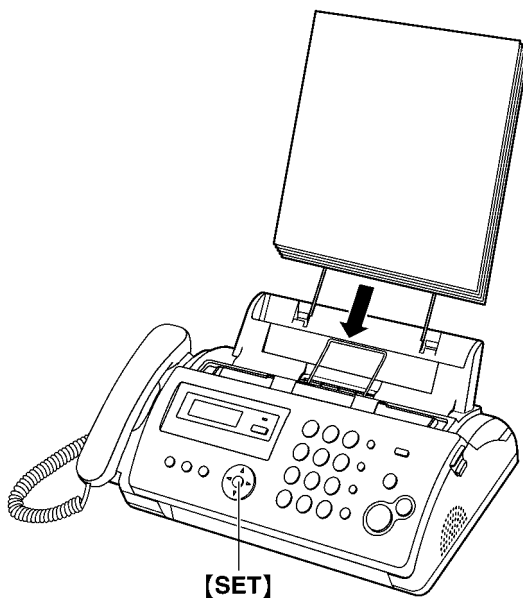

15.3.2. Document Jams - sending

1. Open the front cover. Remove the jammed document carefully (①).

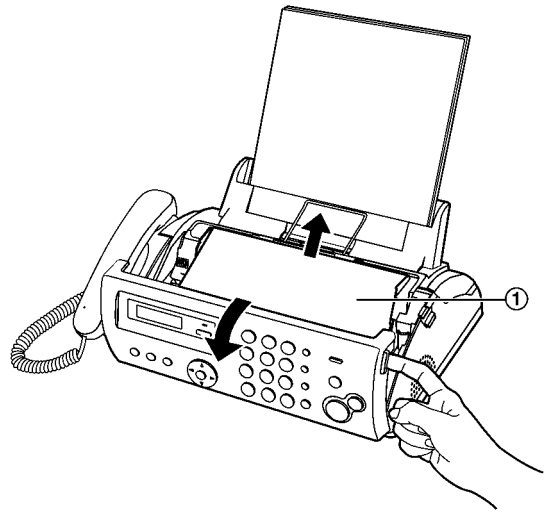

2. Close the front cover securely.

Note:

- Do not pull out the jammed paper forcibly before opening the front cover.

15.4. Cleaning

15.4.1. Document feeder/recording paper feeder/scanner glass cleaning

Clean the document feeder/recording feeder/scanner glass when:

- Documents or recording paper frequently misfeed.
- Smudges or black/white lines appear on the original document when sending or copying.

Important:

- Remove the recording paper, then remove the paper tray beforehand, otherwise the paper may misfeed or jam.

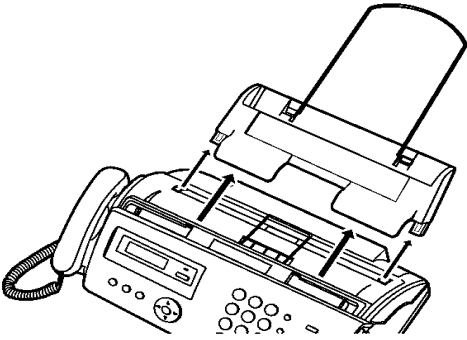

1. Disconnect the power cord and the telephone line cord.
2. Open the front cover (①), push the green button (②), then open the back cover (③).

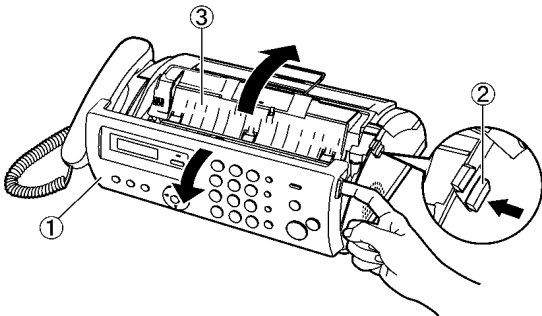

3. Clean the document feeder rollers (④) and rubber flap (⑤) with a cloth moistened with isopropyl rubbing alcohol, and let all parts dry thoroughly. Clean the scanner glass (⑥) with a soft, dry cloth.

- Caution:**
- Do not use paper products, such as paper towels or tissues.

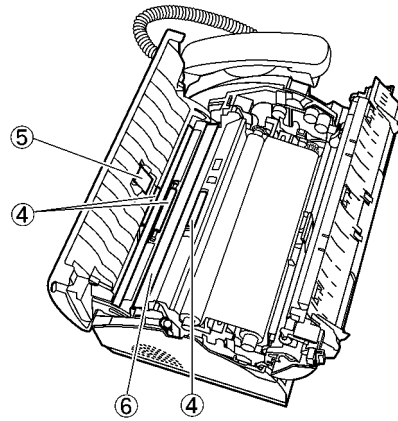

4. Clean the recording paper feeder roller (⑦) with a cloth moistened with isopropyl rubbing alcohol, and let all parts dry thoroughly.

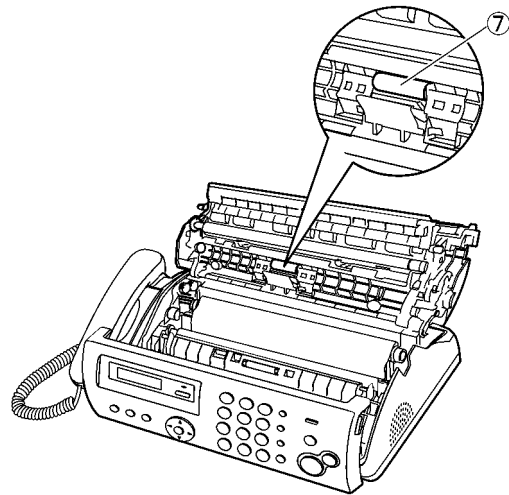

5. Close the back cover securely by pushing down on the dotted area at both ends (⑧), then close the front cover securely (⑨).

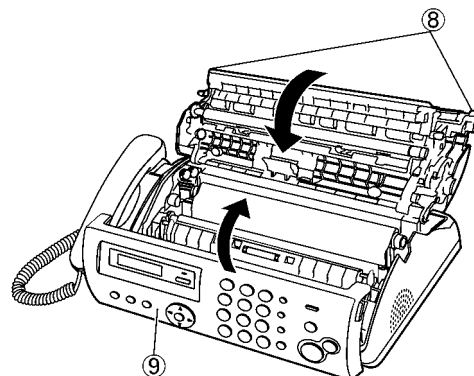

6. Install the paper tray, then insert the recording paper gently.
(See **Installing the Paper Tray** (P.54) and **Installing the Recording Paper** (P.55))

7. Connect the power cord and the telephone line cord.

15.4.2. Thermal Head Cleaning

If smudges or black/white lines appear on a copied/received document, check whether there is dust on the thermal head. Clean the thermal head to remove the dust.

Important:

- Remove the recording paper, then remove the paper tray beforehand, otherwise the paper may misfeed or jam.

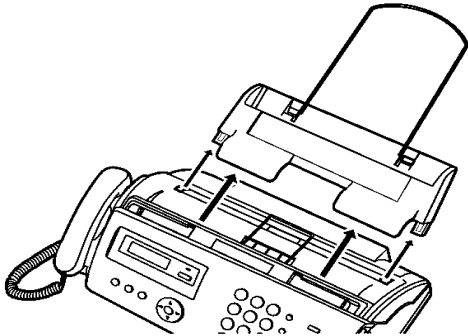

1. Disconnect the power cord and the telephone line cord.
2. Open the front cover (①), push the green button (②), then open the back cover (③).

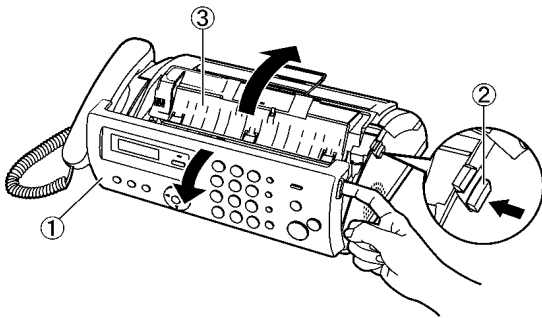

3. Remove the ink film (④).

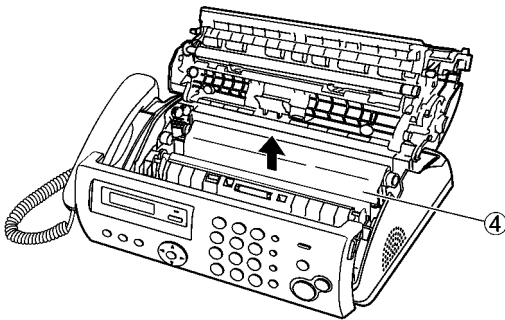

4. Clean the thermal head (⑤) with a cloth moistened with isopropyl rubbing alcohol, and let it dry thoroughly.

Caution:

- To prevent a malfunction due to static electricity, do not use a dry cloth and do not touch the thermal head directly.

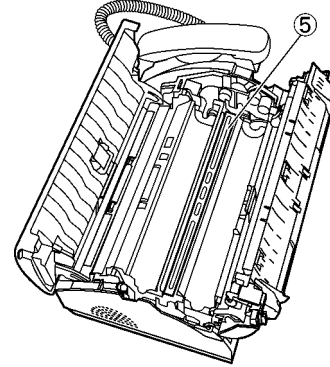

5. Re-install the ink film and close the covers (see step 4 to 7 on **Installing the Ink Film** (P.53)).
6. Install the paper tray, then insert the recording paper gently. (See **Installing the Paper Tray** (P.54) and **Installing the Recording Paper** (P.55))
7. Connect the power cord and the telephone line cord.

16 Miscellaneous

16.1. Terminal Guide of the ICs Transistors and Diodes

16.1.1. Digital Board

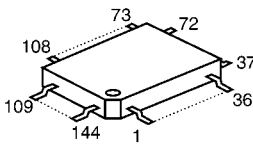
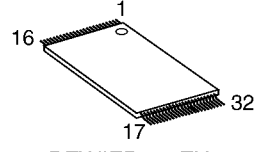
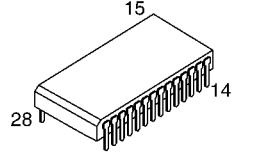
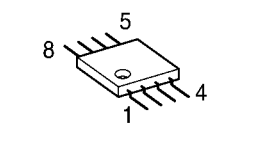
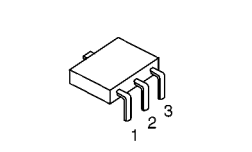
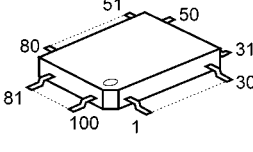
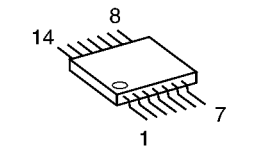
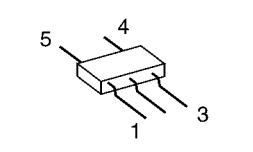
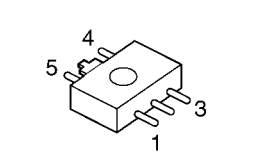
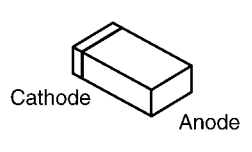
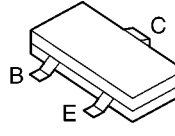
 <p>C1ZBZ0003300</p>	 <p>PFWIFP207FX PFWIFP218FX 3FBKC000135</p>	 <p>C3ABKC000034</p>	 <p>C0ABEB000023 C1AB00002556</p>	 <p>C0CBADD00009</p>
 <p>C1CB00001959 C1CB00002325</p>	 <p>C0JBAS000185</p>	 <p>C0JBAA000393 C0JBAE000333</p>	 <p>C0CBCBD00047</p>	 <p>Cathode Anode MA111</p>
 <p>B1GBCFGG00028, B1ABDF000026, 2SB1218ARL B1GBCFJJ00048, B1ABDF000025,</p>				

16.1.2. Analog Board

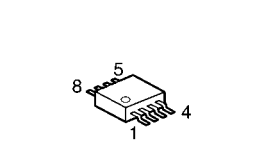
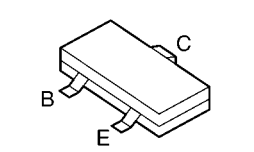
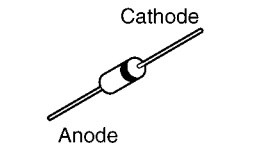
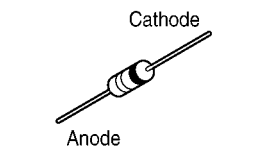
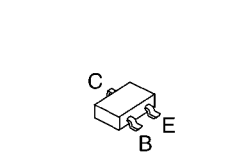
 <p>C0ABEB000083</p>	 <p>B1ABDF000026 B1GBCFEN0010</p>	 <p>Cathode Anode B0EAAD000001</p>	 <p>Cathode Anode MA4240 MA4030</p>	 <p>C E B B0ADEJ000026</p>
--	--	---	---	---

16.1.3. Operation Board

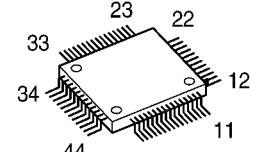
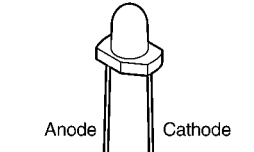
 <p>C1ZBZ0002089</p>	 <p>Anode Cathode B3AAA0000534</p>			
--	---	--	--	--

16.1.4. Power Supply Board

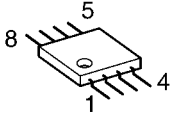
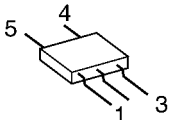
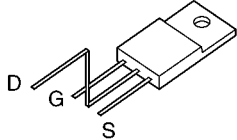
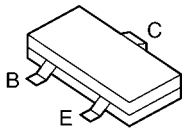
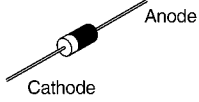
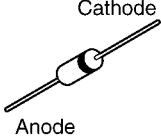
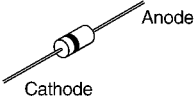
 <p>PFVIFA5518N</p>	 <p>TL431CDBVR</p>	 <p>FQPF4N90C</p>	 <p>2SC3928</p>	 <p>PFVD1N4005 PFVDD1NL20U</p>
 <p>MA165</p>	 <p>PQVDPR1007</p>			

16.1.5. Interface Board

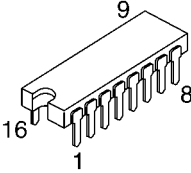
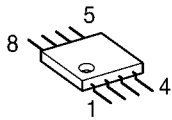
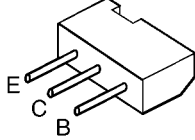
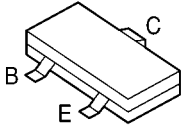
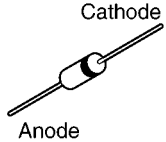
 <p>B1HAGFF00015</p>	 <p>B1CHRD000003</p>	 <p>2SB1322</p>	 <p>PQVTDTC143E</p>	 <p>1SS133 B0BA7R900004</p>
--	--	---	--	---

16.2. How to Replace the Flat Package IC

Even if you do not have the special tools (for example, a spot heater) to remove the Flat IC, with some solder (large amount), a soldering iron and a cutter knife, you can easily remove the ICs that have more than 100 pins.

16.2.1. Preparation

- PbF (: Pb free) Solder

- Soldering Iron

Tip Temperature of 700°F ± 20°F (370°C ± 10°C)

Note: We recommend a 30 to 40 Watt soldering iron. An expert may be able to use a 60 to 80 Watt iron where someone with less experience could overheat and damage the PCB foil.

- Flux

Recommended Flux: Specific Gravity → 0.82.

Type → RMA (lower residue, non-cleaning type)

Note: See **About Lead Free Solder (PbF: Pb free)** (P.6).

16.2.2. Flat Package IC Removal Procedure

1. Put plenty of solder on the IC pins so that the pins can be completely covered.

Note:

If the IC pins are not soldered enough, you may give pressure to the P.C. board when cutting the pins with a cutter.

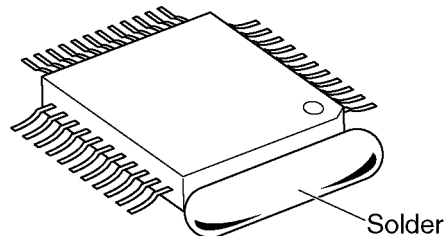

2. Make a few cuts into the joint (between the IC and its pins) first and then cut off the pins thoroughly.

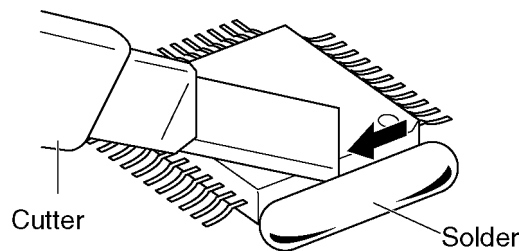

3. While the solder melts, remove it together with the IC pins.

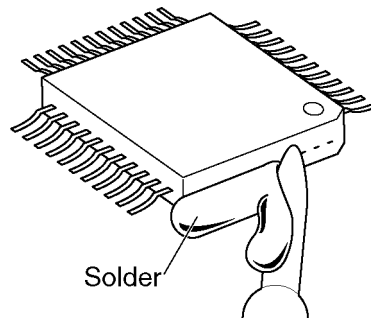

When you attach a new IC to the board, remove all solder left on the land with some tools like a soldering wire. If some solder is left at the joint on the board, the new IC will not be attached properly.

16.2.3. Flat Package IC Installation Procedure

1. Temporarily fix the FLAT PACKAGE IC, soldering the two marked pins.

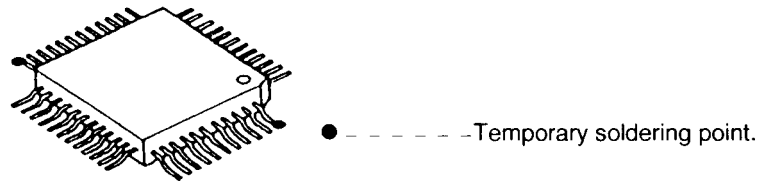

*Check the accuracy of the IC setting with the corresponding soldering foil.

2. Apply flux to all pins of the FLAT PACKAGE IC.

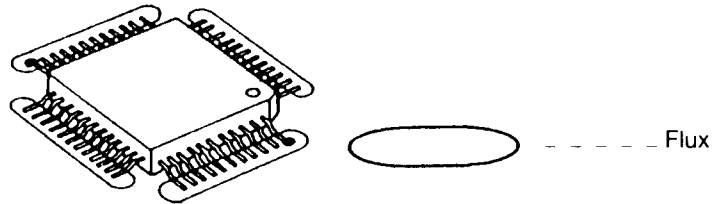

3. Solder the pins, sliding the soldering iron in the direction of the arrow.

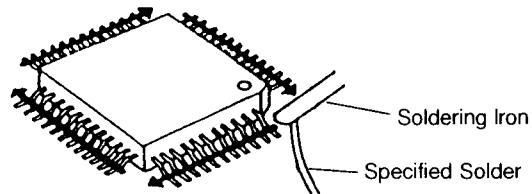

16.2.4. Bridge Modification Procedure

1. Lightly resolder the bridged portion.
2. Remove the remaining solder along the pins using a soldering iron as shown in the figure below.

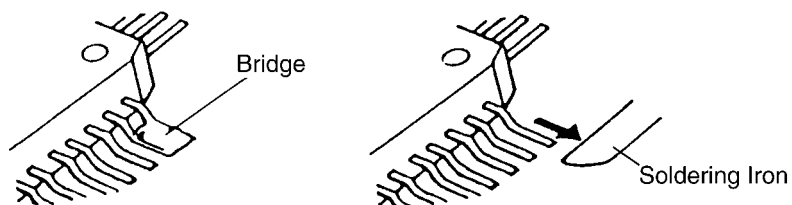

16.3. Test Chart

16.3.1. ITU-T No.1 Test chart



THE SLEREXE COMPANY LIMITED

SAPORS LANE - BOOLE - DORSET - BH 25 8 ER

TELEPHONE BOOLE (945 13) 51617 - TELEX 123456

Our Ref. 350/PJC/EAC

18th January, 1972.

Dr. P.N. Cundall,
Mining Surveys Ltd.,
Holroyd Road,
Reading,
Berks.

Dear Pete,

Permit me to introduce you to the facility of facsimile transmission.

In facsimile a photocell is caused to perform a raster scan over the subject copy. The variations of print density on the document cause the photocell to generate an analogous electrical video signal. This signal is used to modulate a carrier, which is transmitted to a remote destination over a radio or cable communications link.

At the remote terminal, demodulation reconstructs the video signal, which is used to modulate the density of print produced by a printing device. This device is scanning in a raster scan synchronised with that at the transmitting terminal. As a result, a facsimile copy of the subject document is produced.

Probably you have uses for this facility in your organisation.

Yours sincerely,

Phil.

P.J. CROSS
Group Leader - Facsimile Research

16.3.3. Test Chart

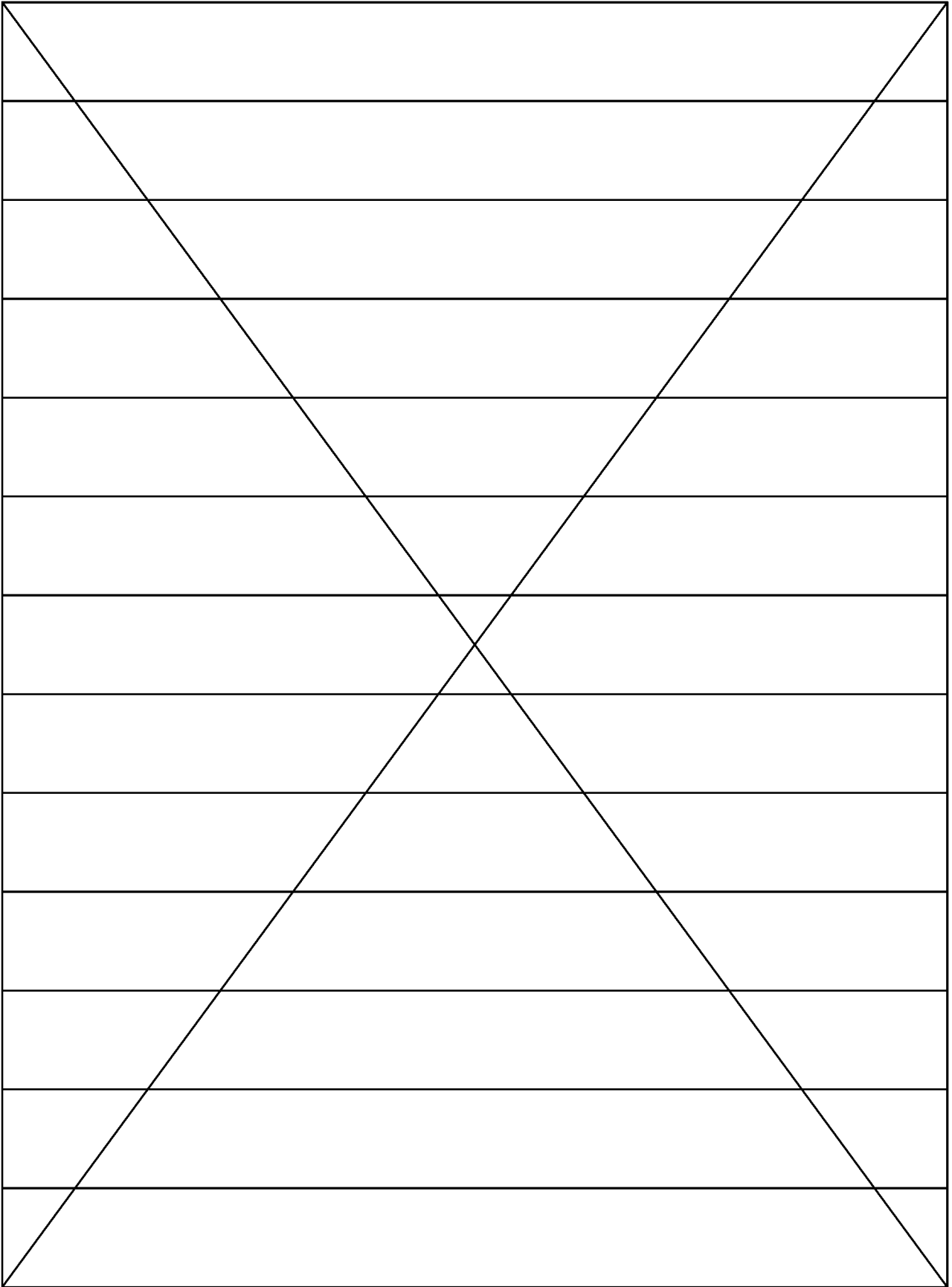

17 Schematic Diagram

17.1. Digital Board (PCB1) (KX-FP207FX)

1/4

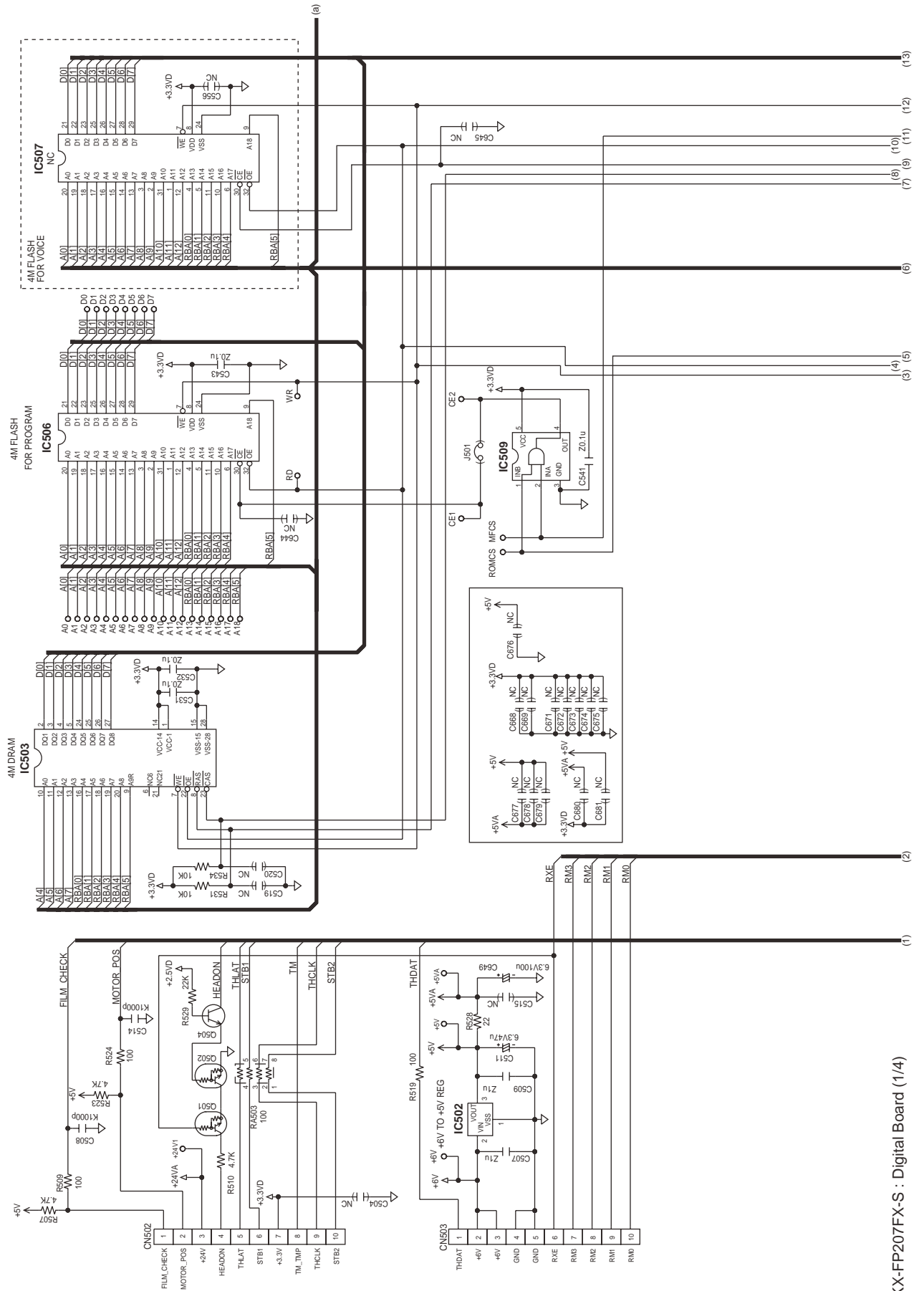

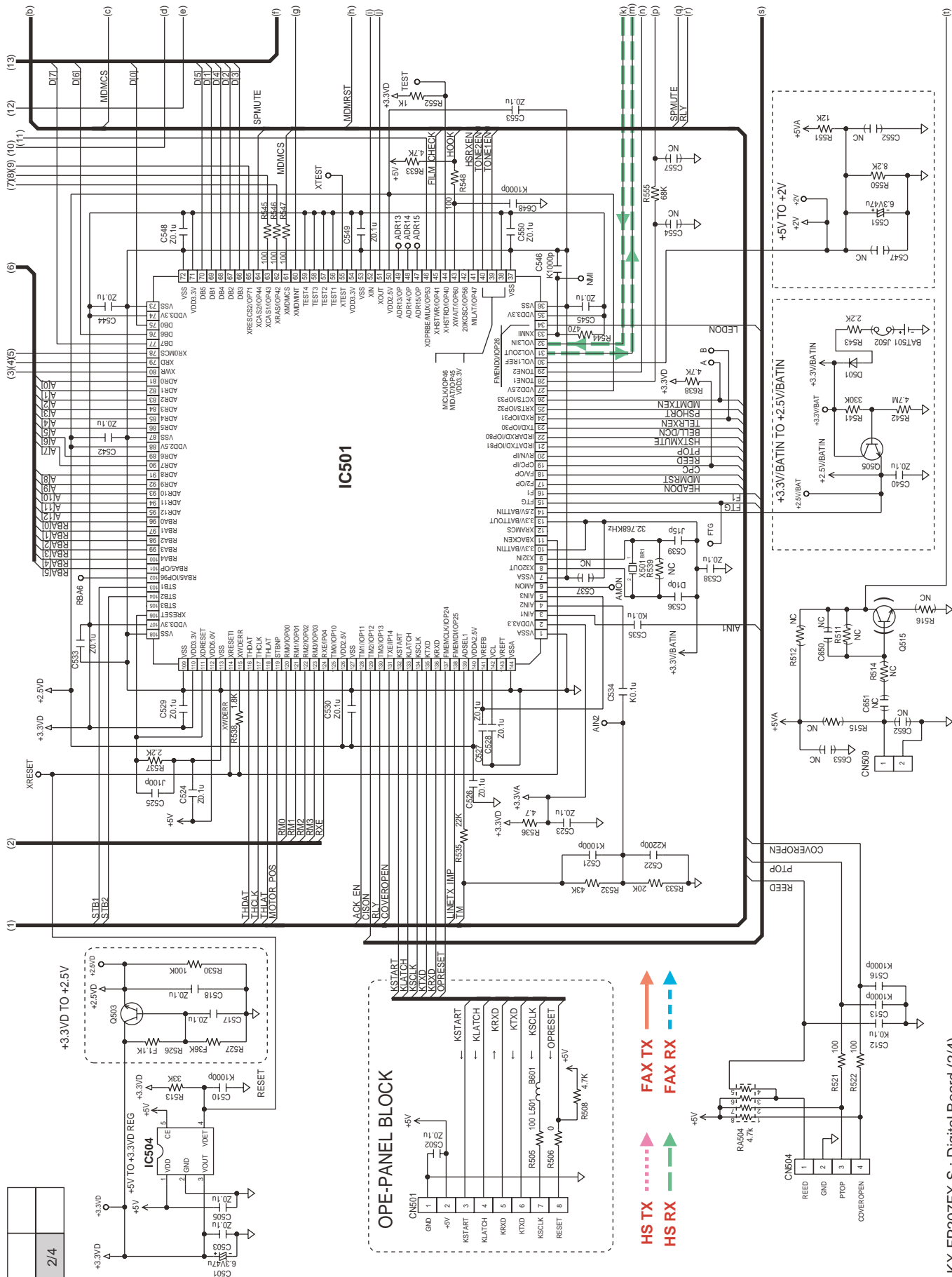

KX-FP207FX-S : Digital Board (2/4)

3/4	
-----	--

→ HS TX
→ FAX TX
→ HS RX
→ FAX RX

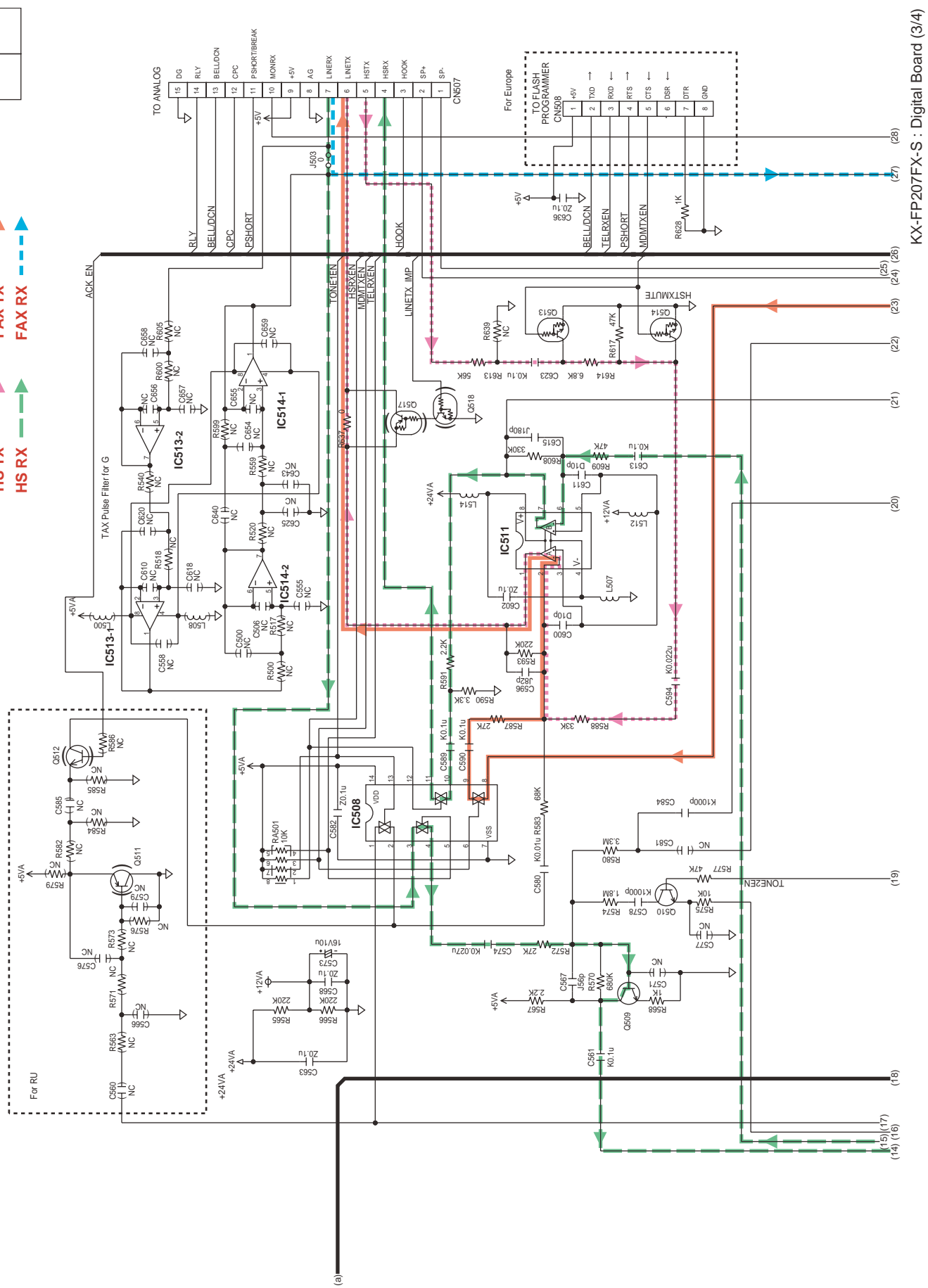

KX-FP207FX-S : Digital Board (3/4)

	4/4
--	-----

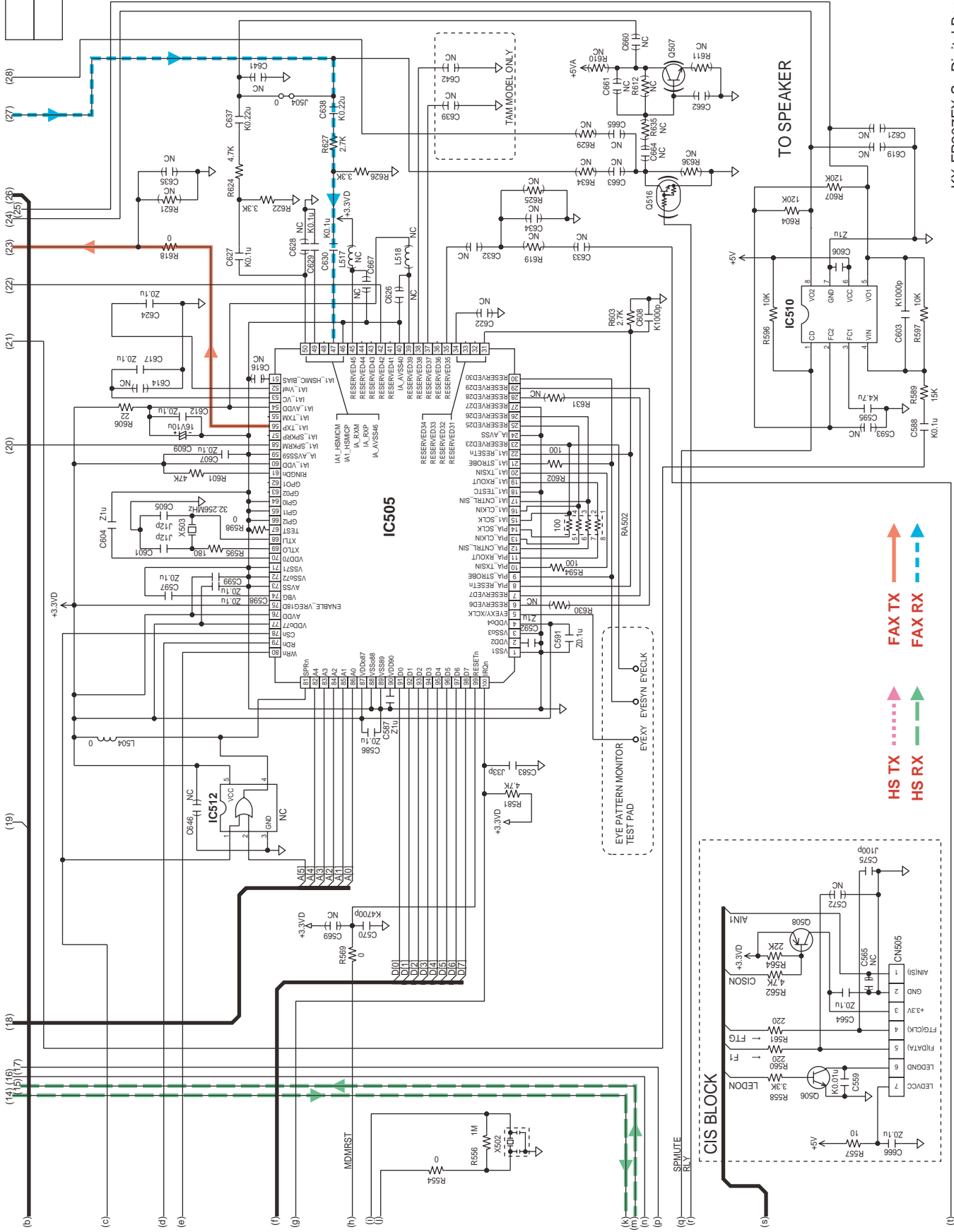

KX-FP207FX-S : Digital Board (4/4)

17.2. Digital Board (PCB1) (KX-FP218FX)

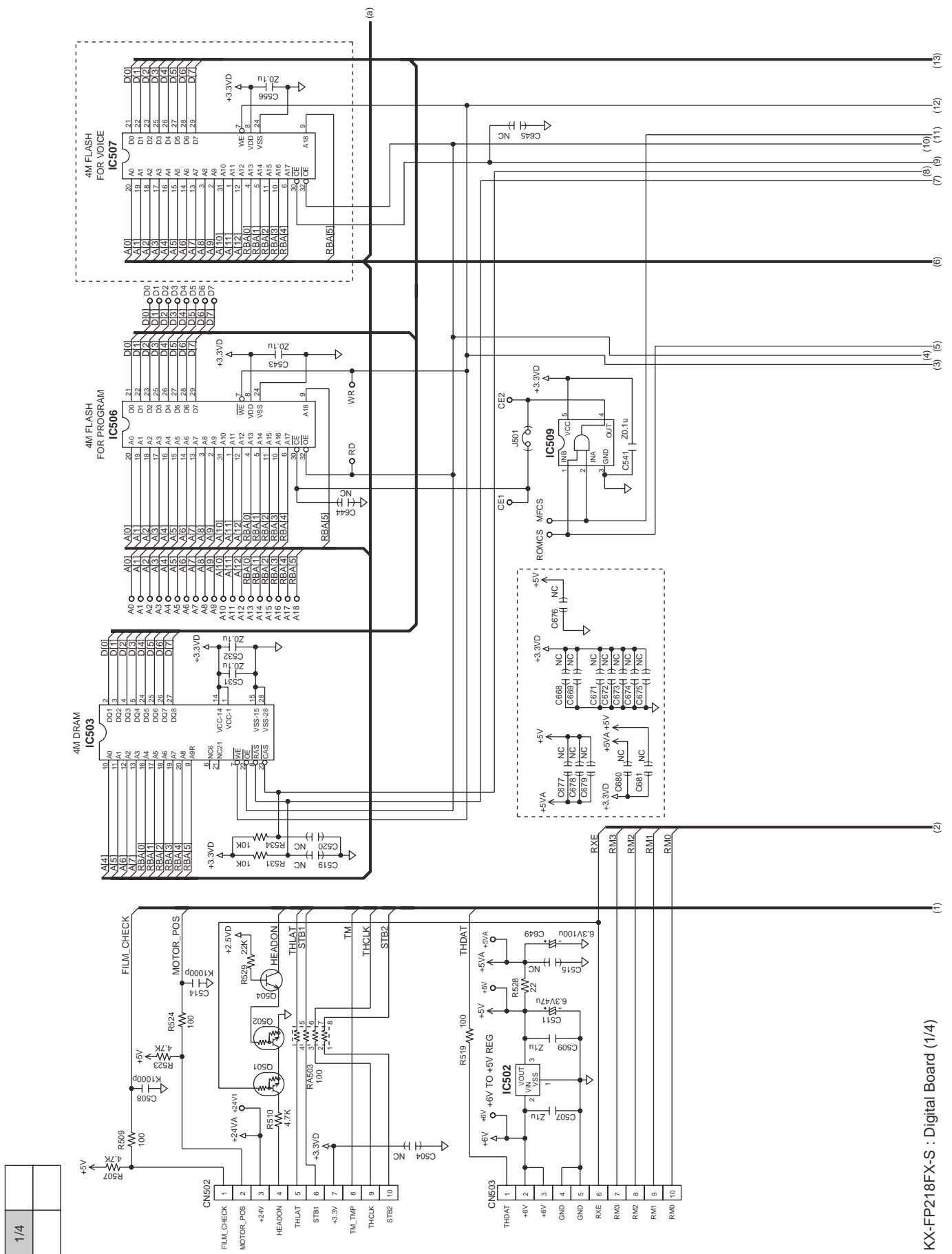

KX-FP218FX-S : Digital Board (1/4)

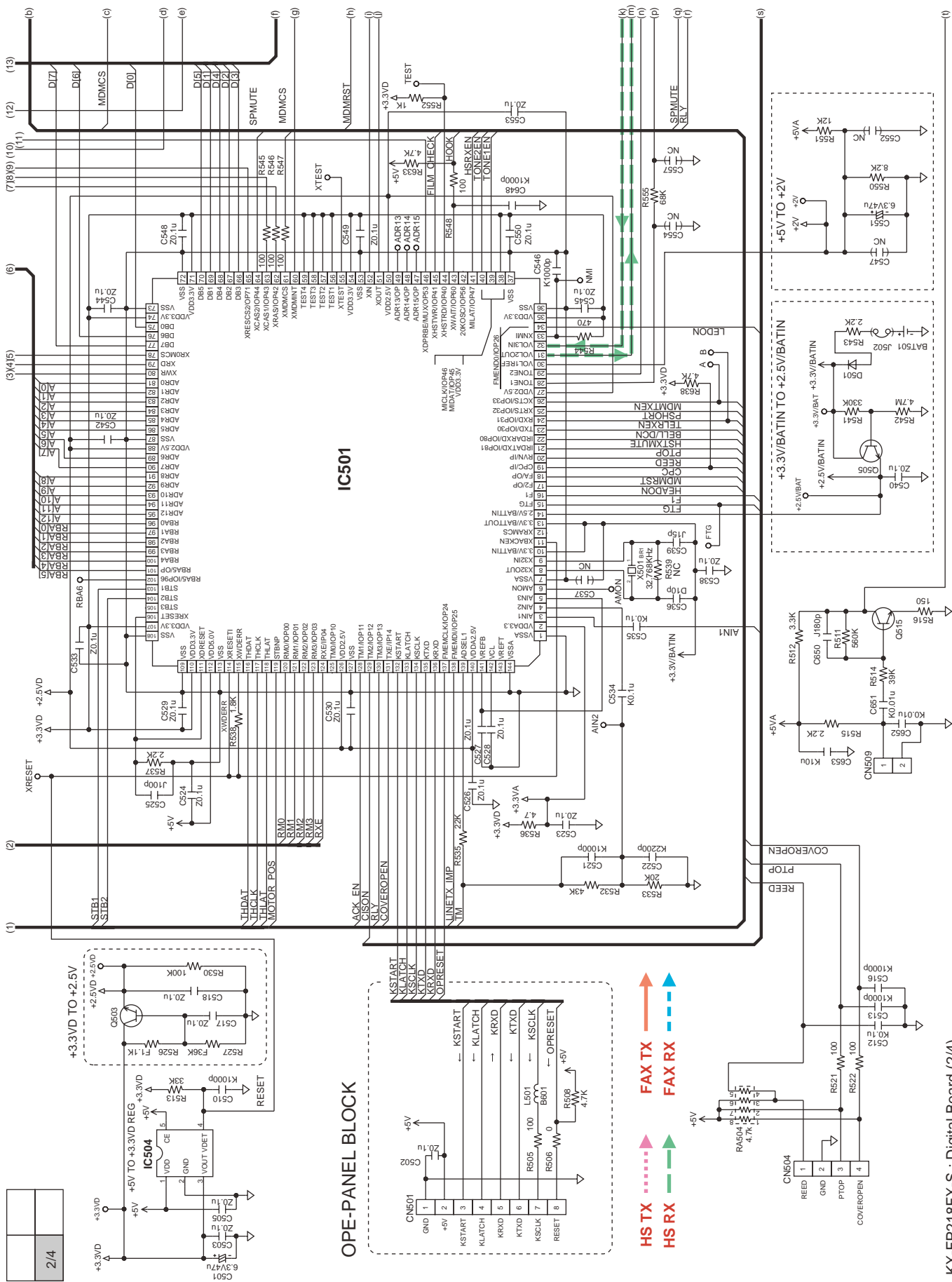

KX-FP218FX-S : Digital Board (2/4)

3/4	
-----	--

→ FAX TX
→ FAX RX
→ HS TX
→ HS RX

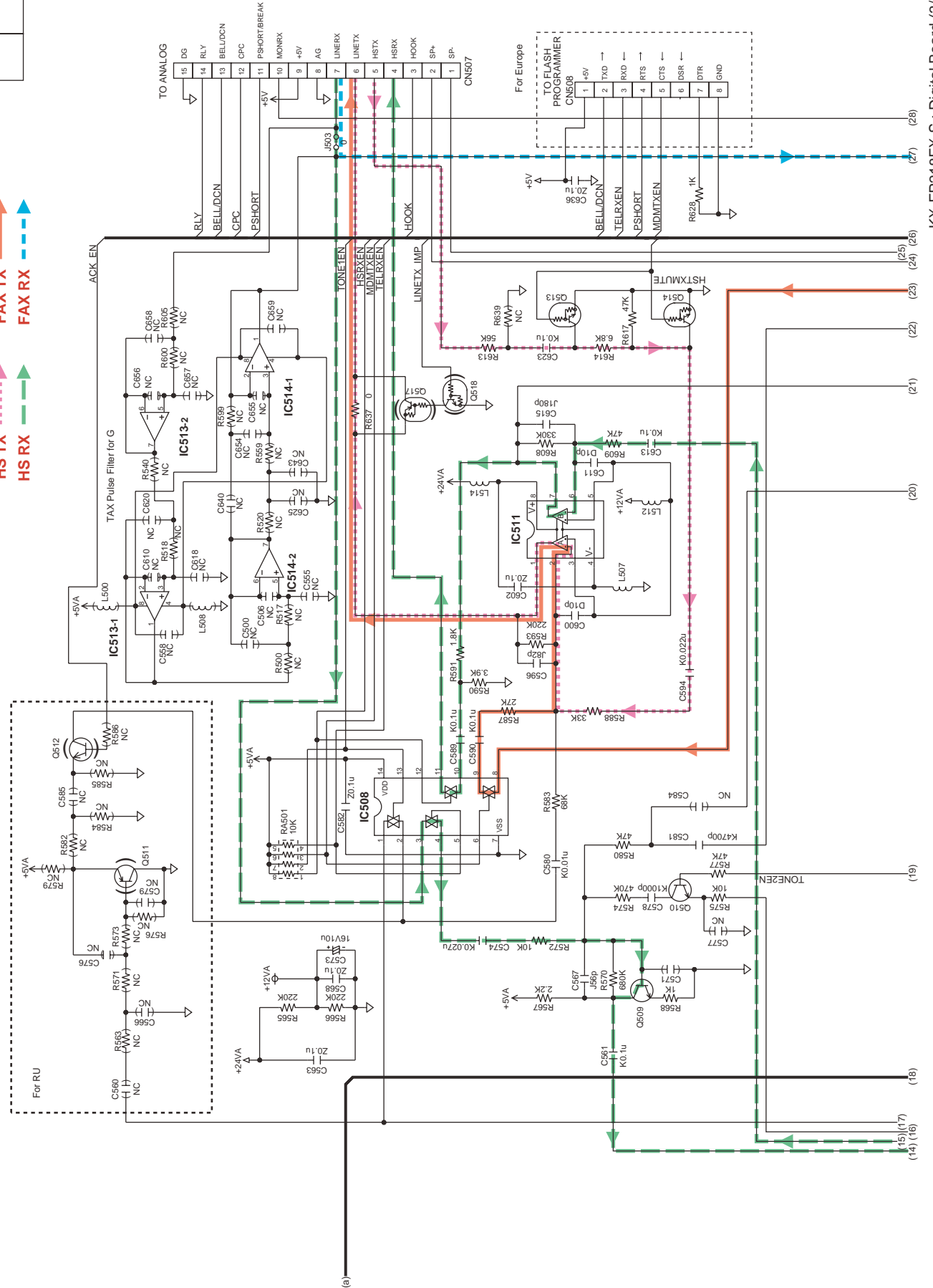

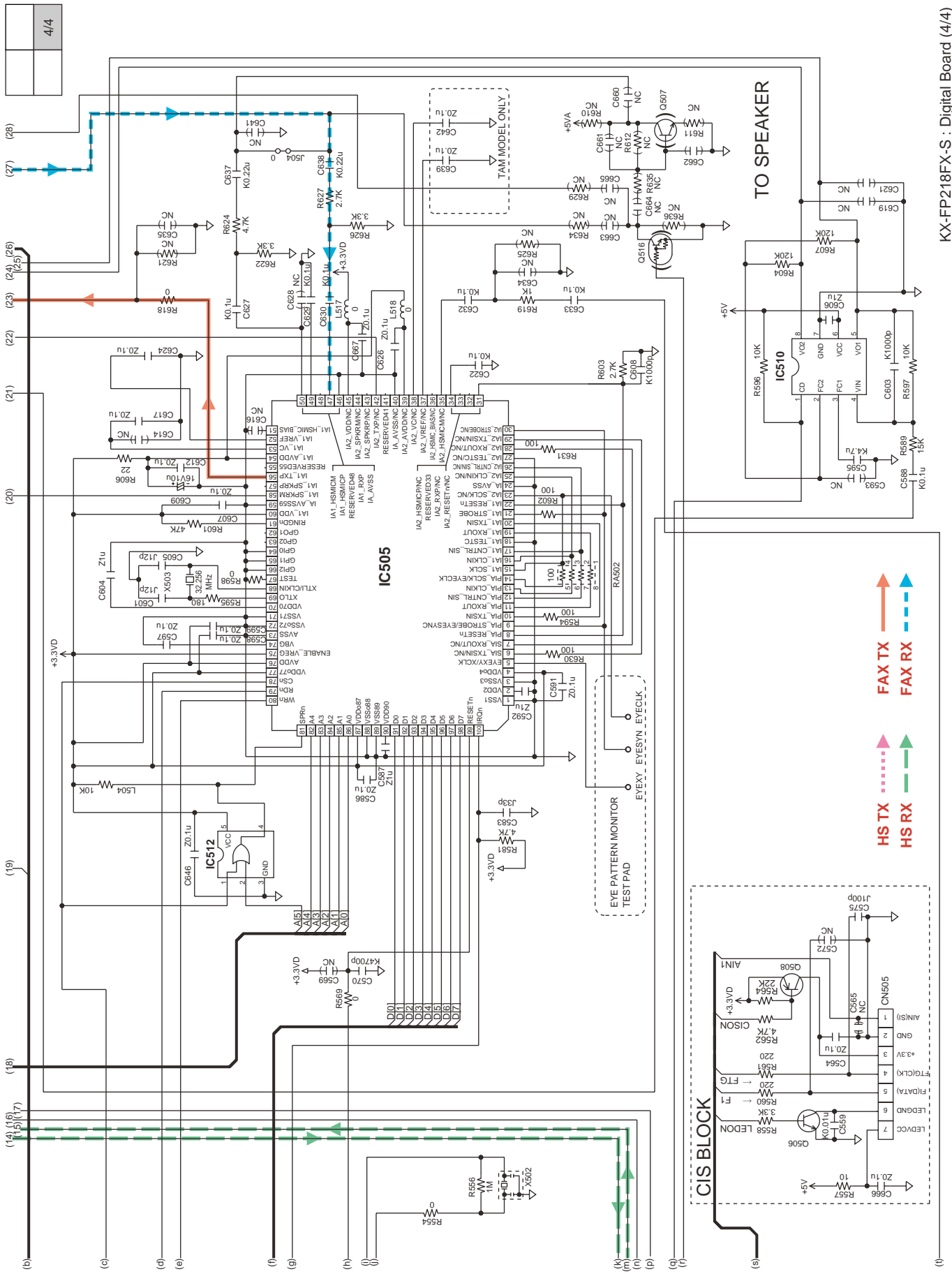

KX-FP218FX-S : Digital Board (4/4)

17.3. Analog Board (PCB2) (KX-FP207FX)

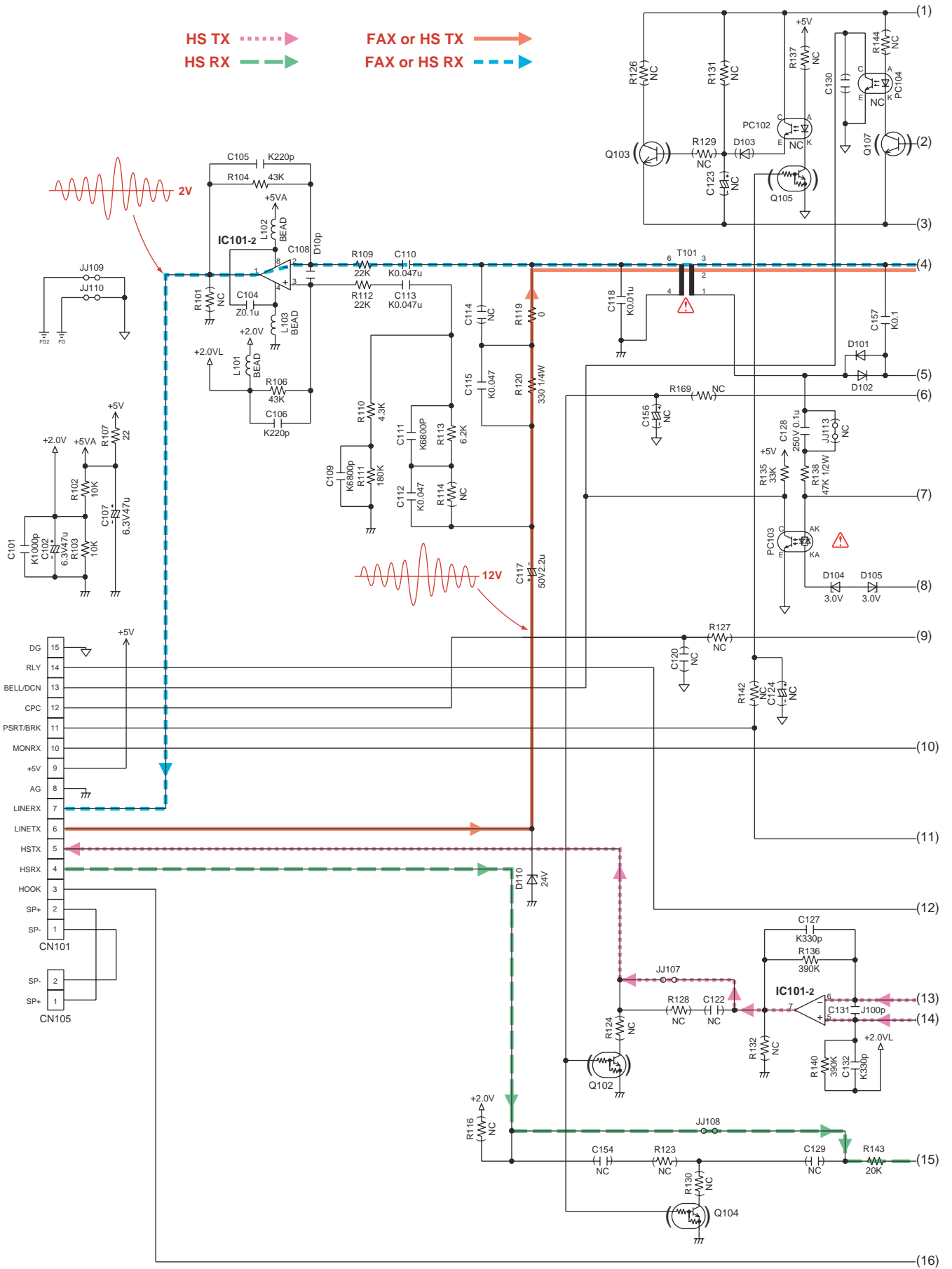

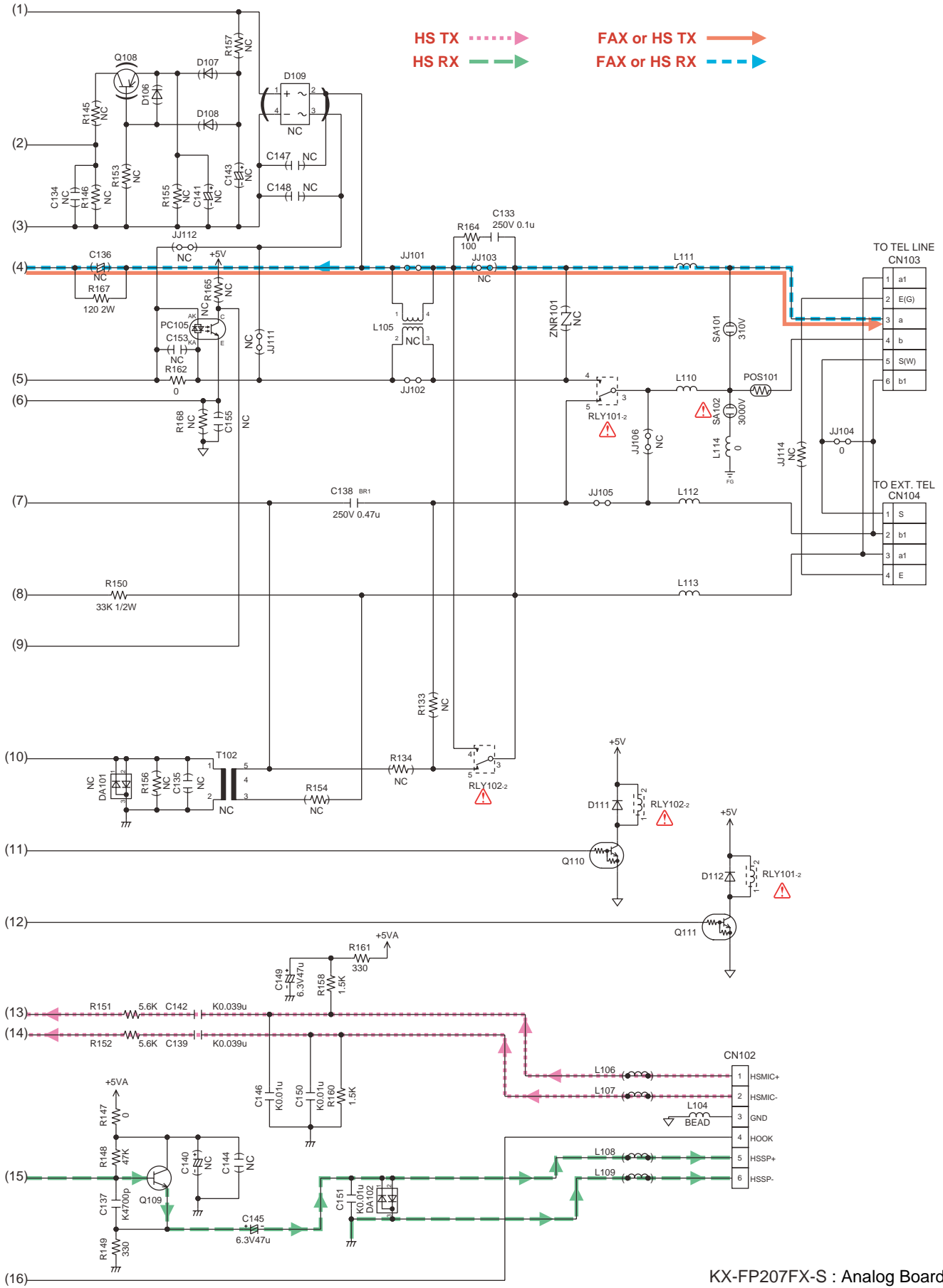

KX-FP207FX-S : Analog Board

17.4. Analog board (PCB2) (KX-FP218FX)

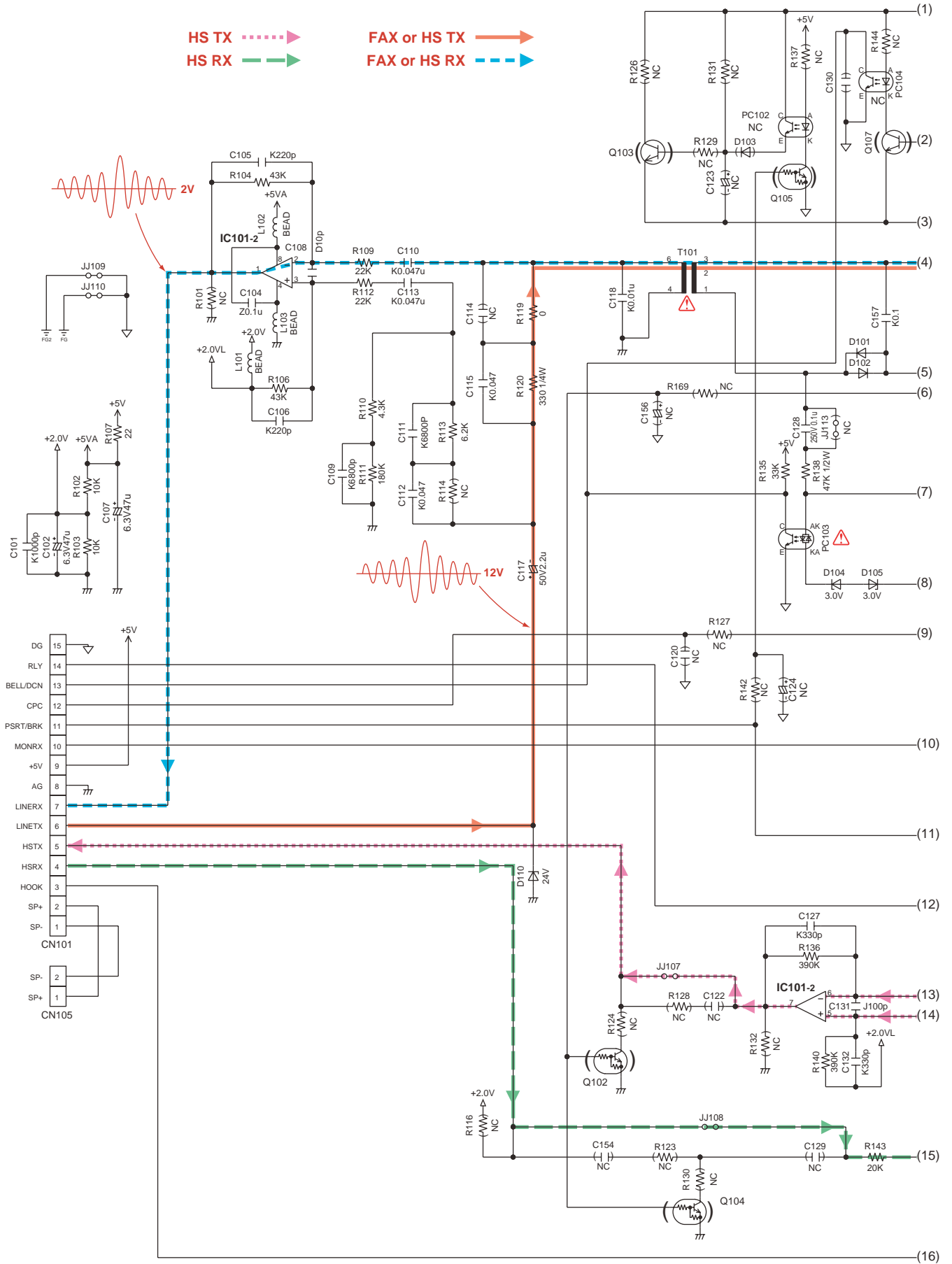

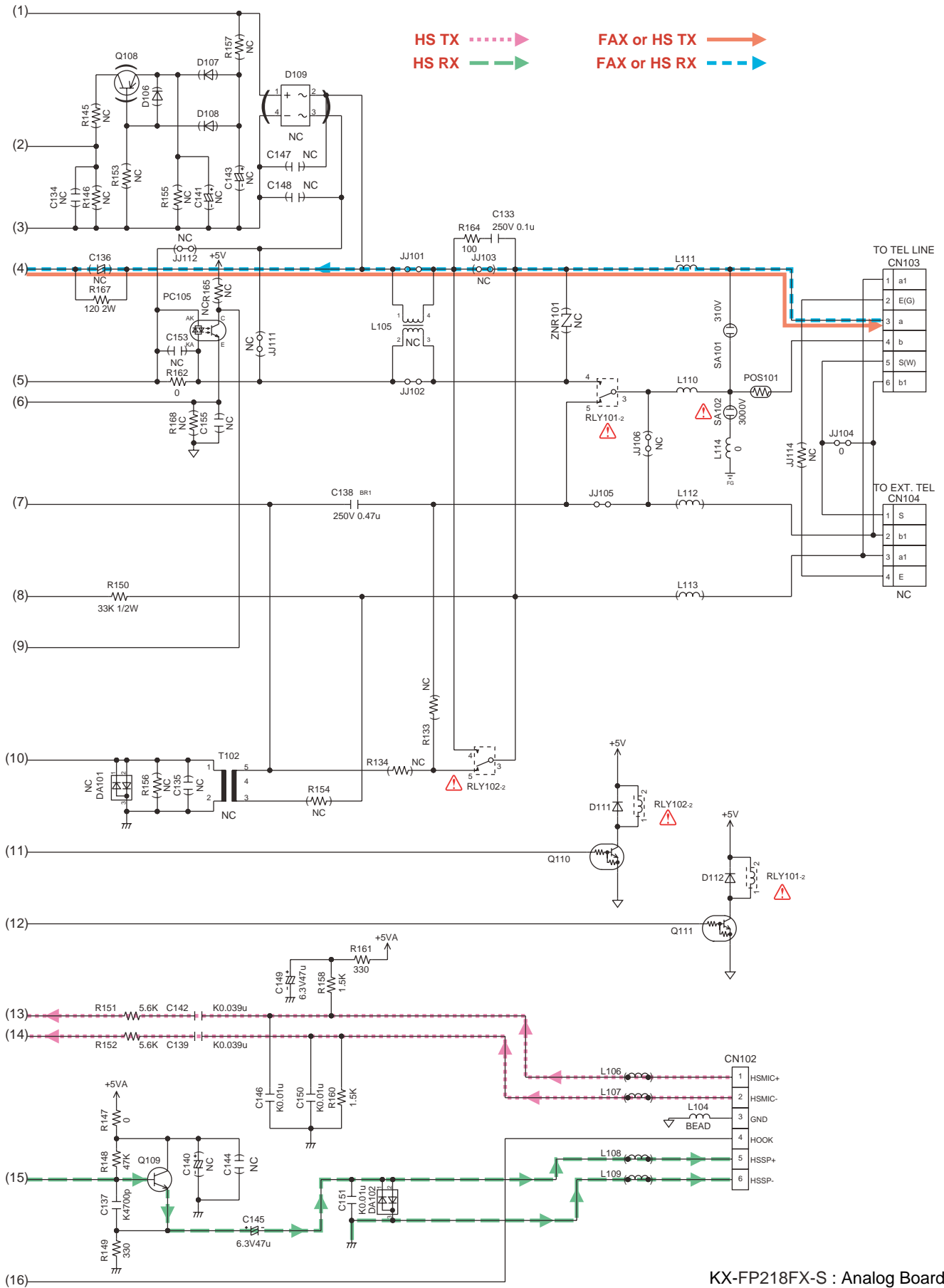

KX-FP218FX-S : Analog Board

17.5. Operation Board (PCB3) (KX-FP207FX)

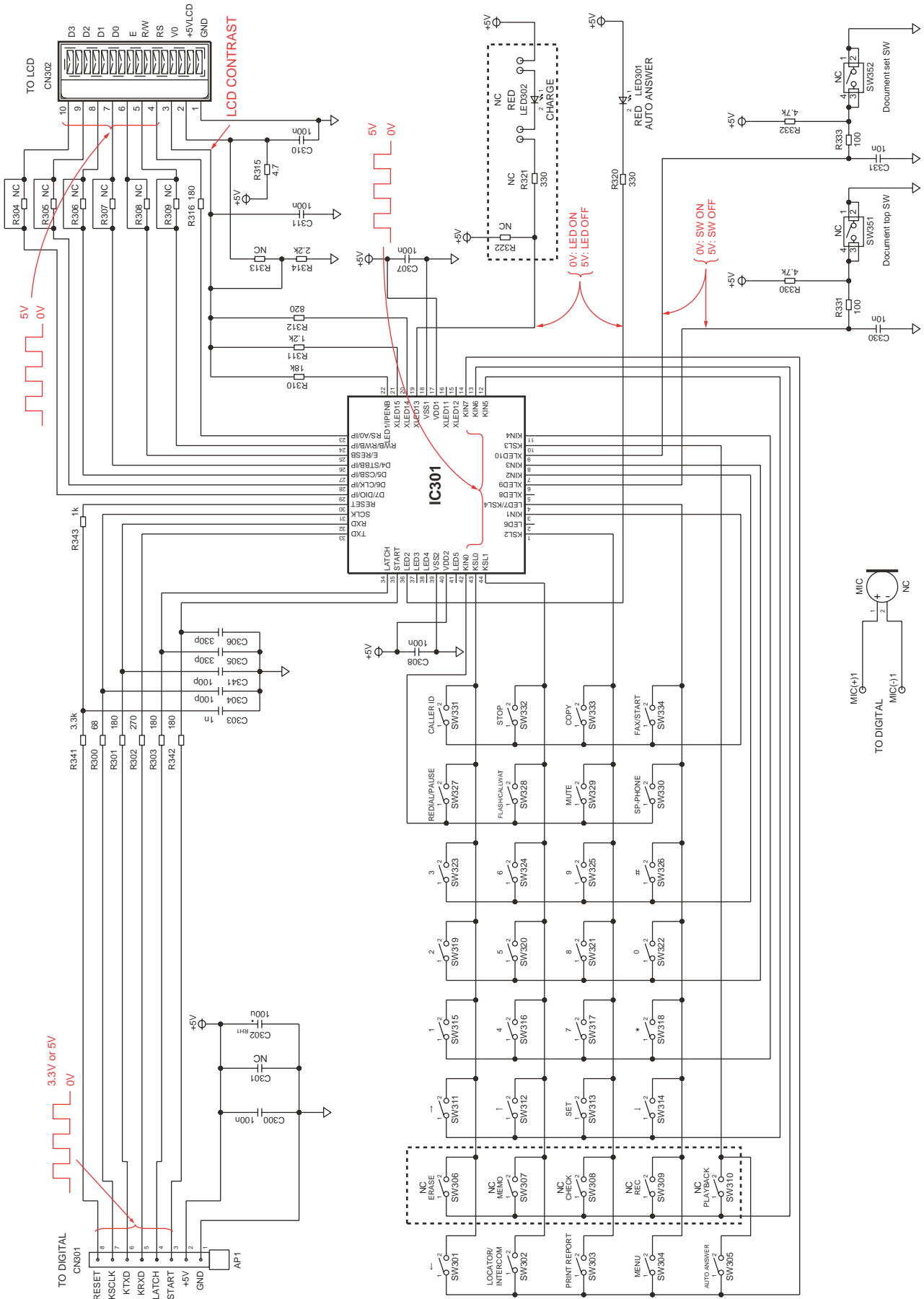

KX-FP207FX-S : Operation Board

17.6. Operation Board (PCB3) (KX-FP218FX)

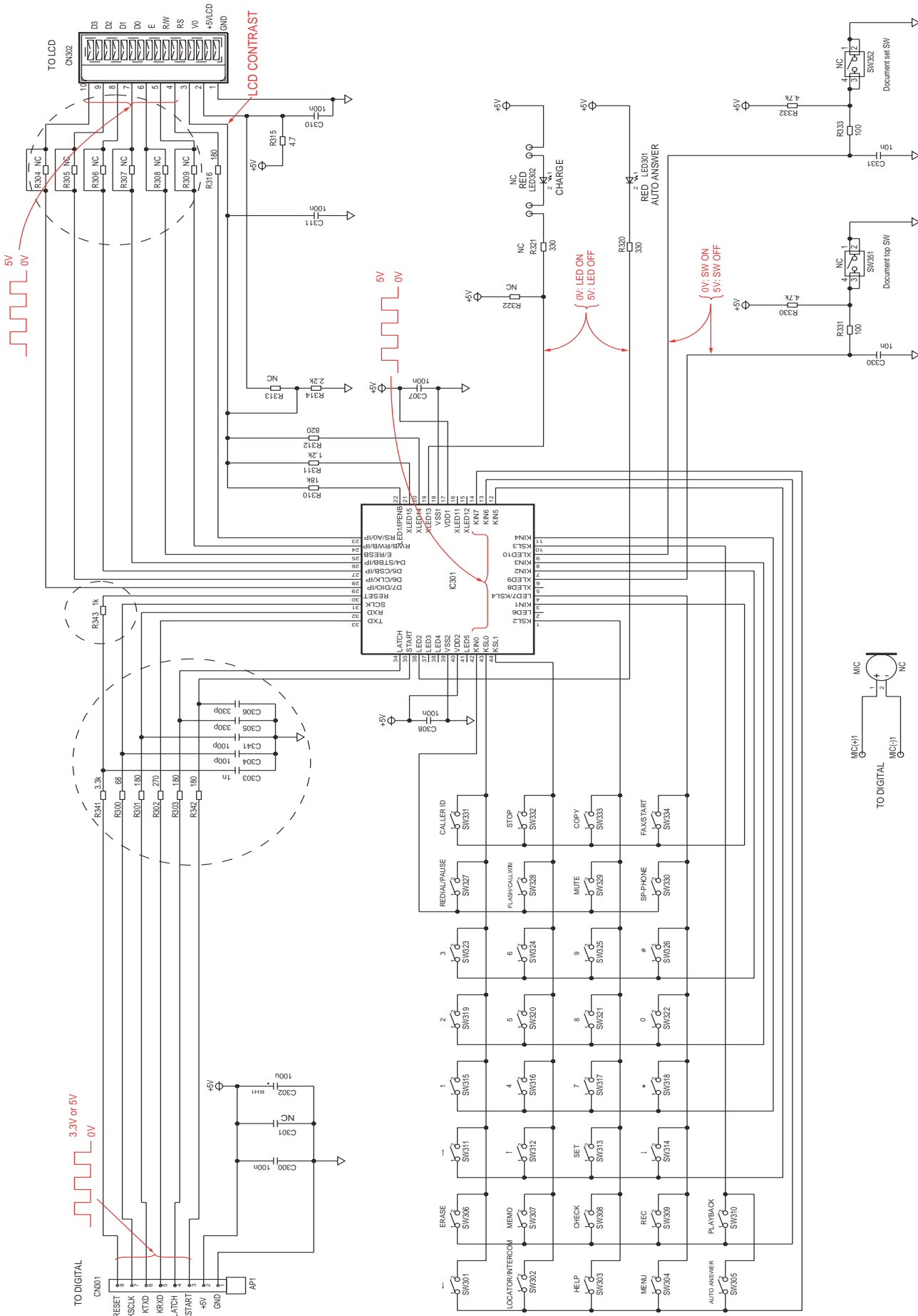

KX-FP218FX-S : Operation Board

17.7. Power Supply Board (PCB4)

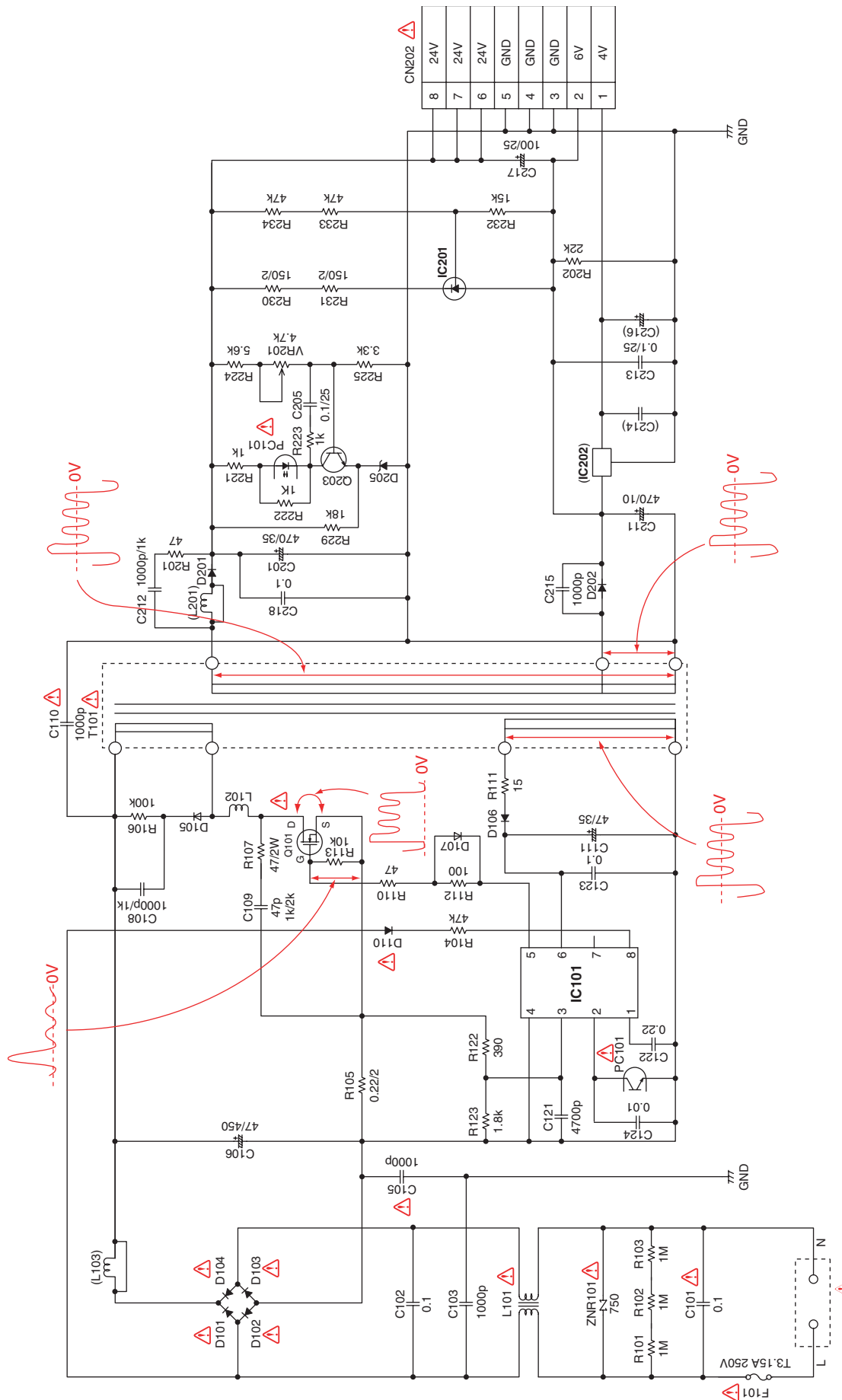

KX-FP207/218FX-S : POWER SUPPLY BOARD

17.8. Interface Board (PCB5)

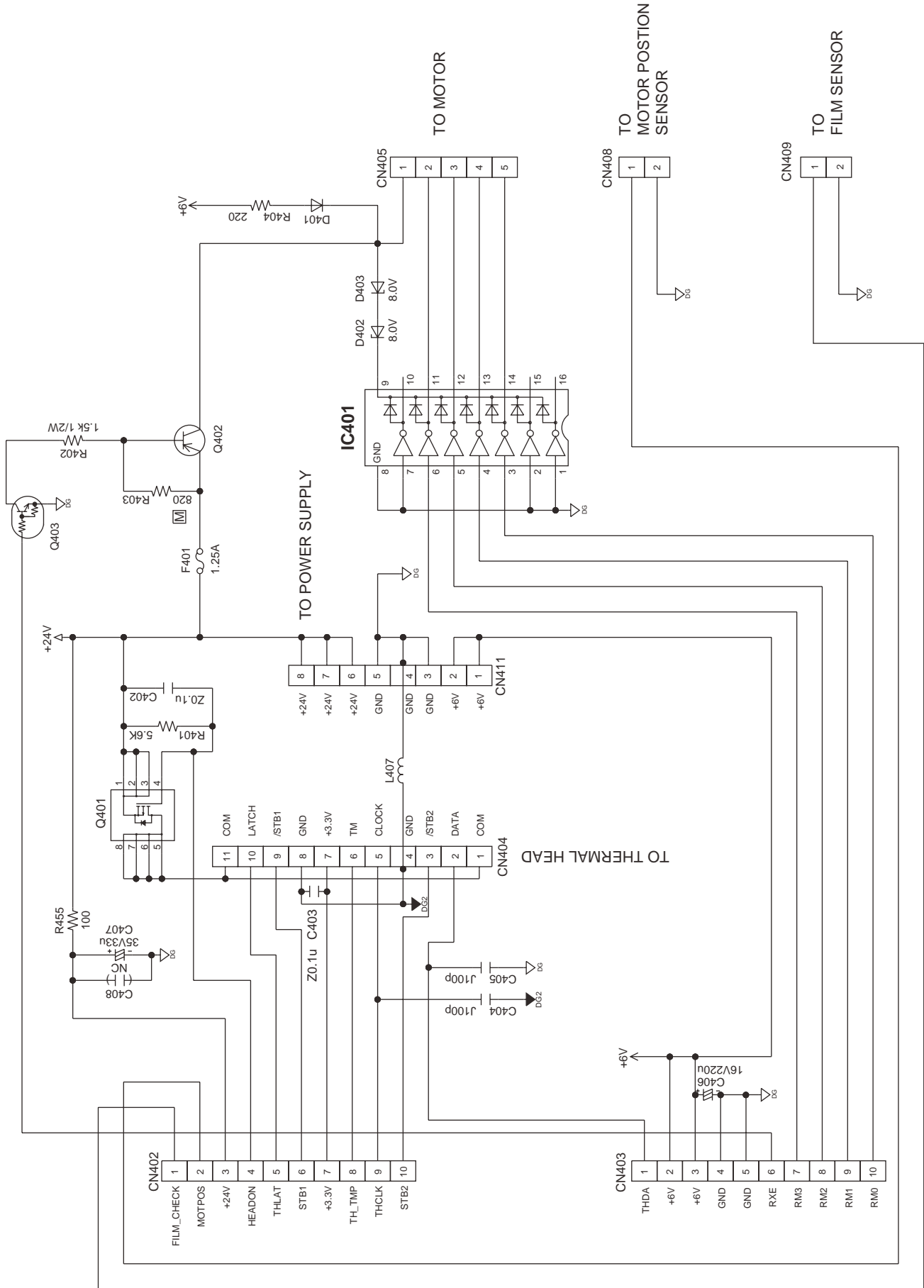

KX-FP207/218FX-S : Interface Board

17.9. Sensor Board (PCB6)

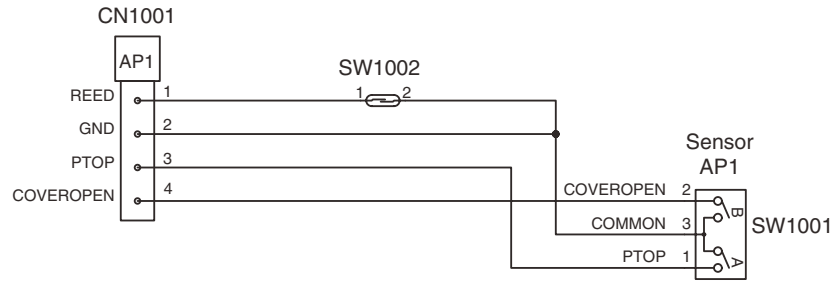

KX-FP207/218FX-S : Sensor Board

17.10. Film End SensorBoard (PCB7)

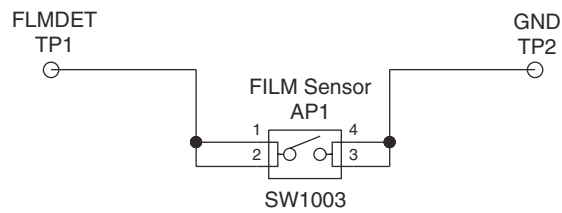

KX-FP207/218FX-S : Film End Sensor Board

17.11. Motor Position Sensor Board (PCB8)

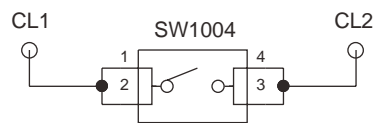

KX-FP207/218FX-S : Motor Position Sensor Board

17.12. Hook Switch Board (PCB9)

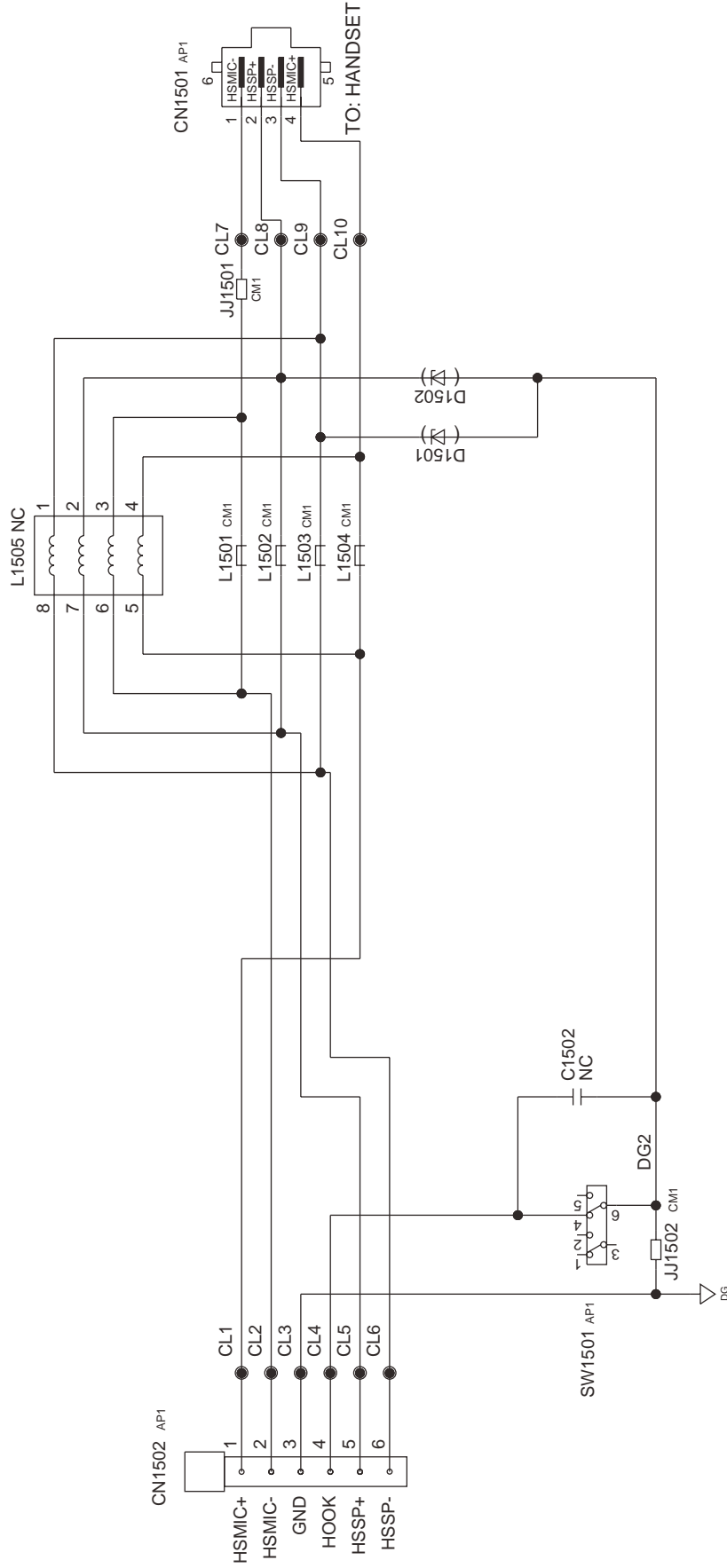

KX-FP207/218FX-S : Hook Switch Board

MEMO:

18 Printed Circuit Board

18.1. Digital Board (PCB1)

18.1.1. Bottom View

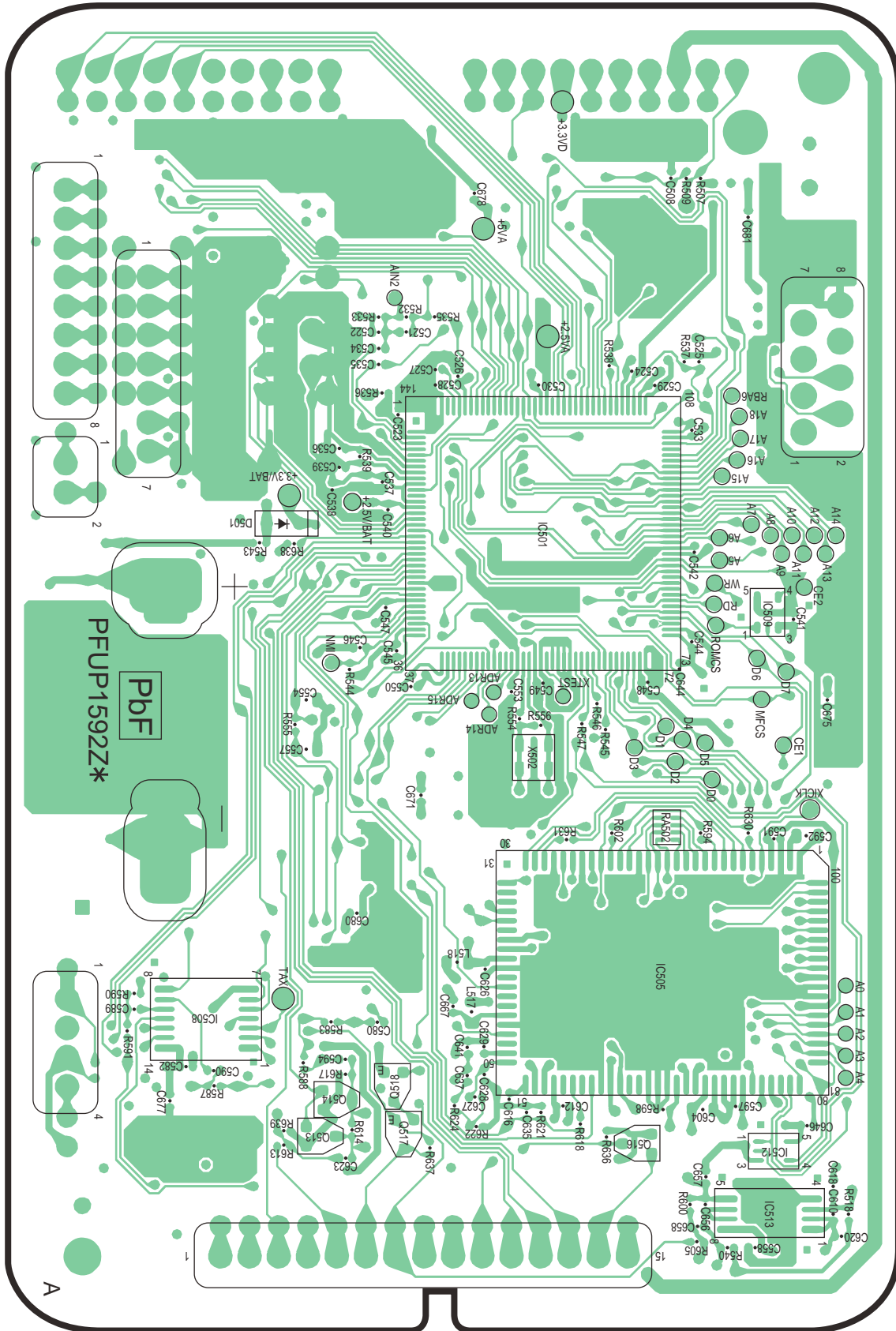

KX-FP207/218FX-S: DIGITAL Board (Bottom View)

18.1.2. Component View

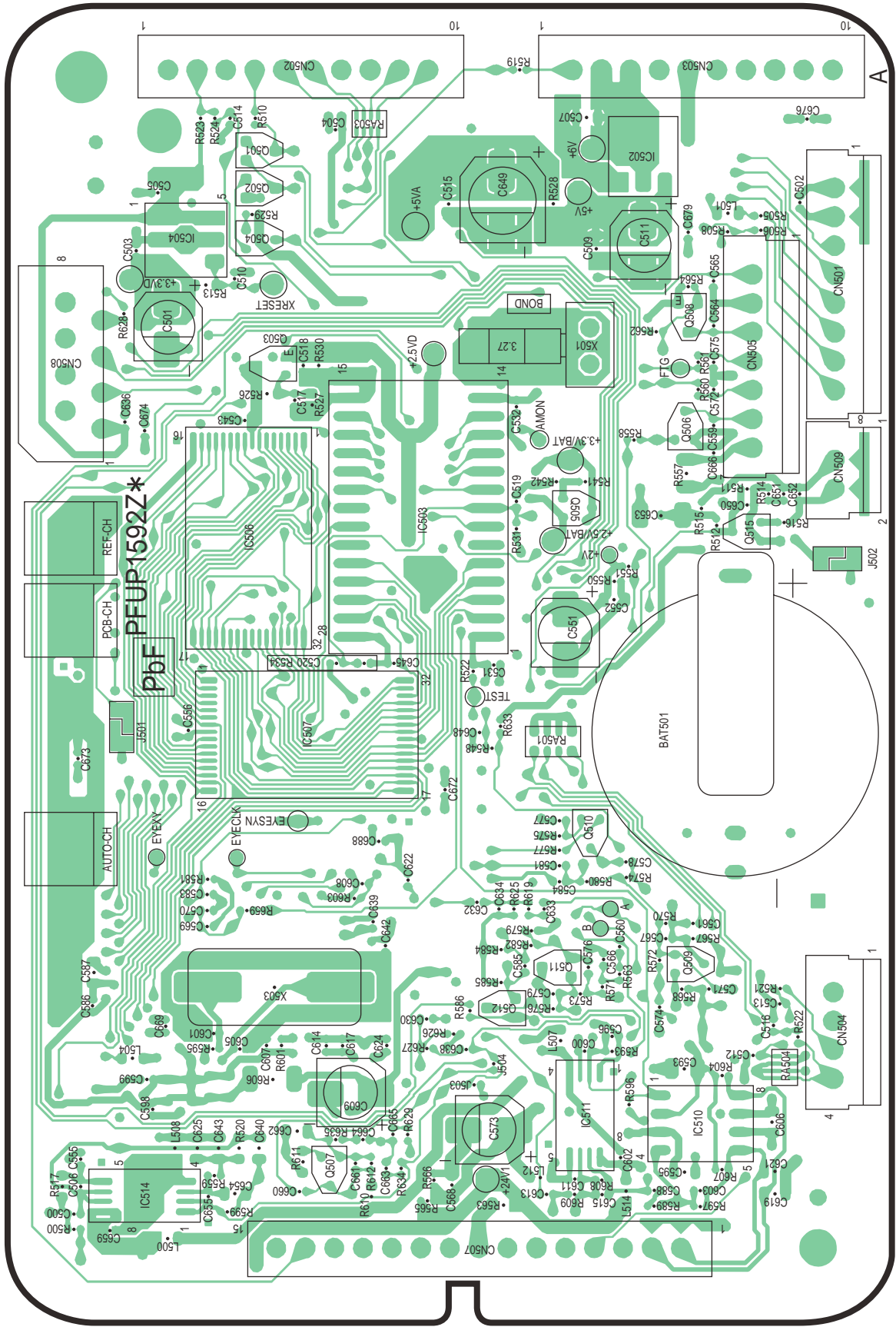

KX-FP207/218FX-S: DIGITAL Board (Component View)

18.2. Analog Board (PCB2)

18.2.1. Bottom View

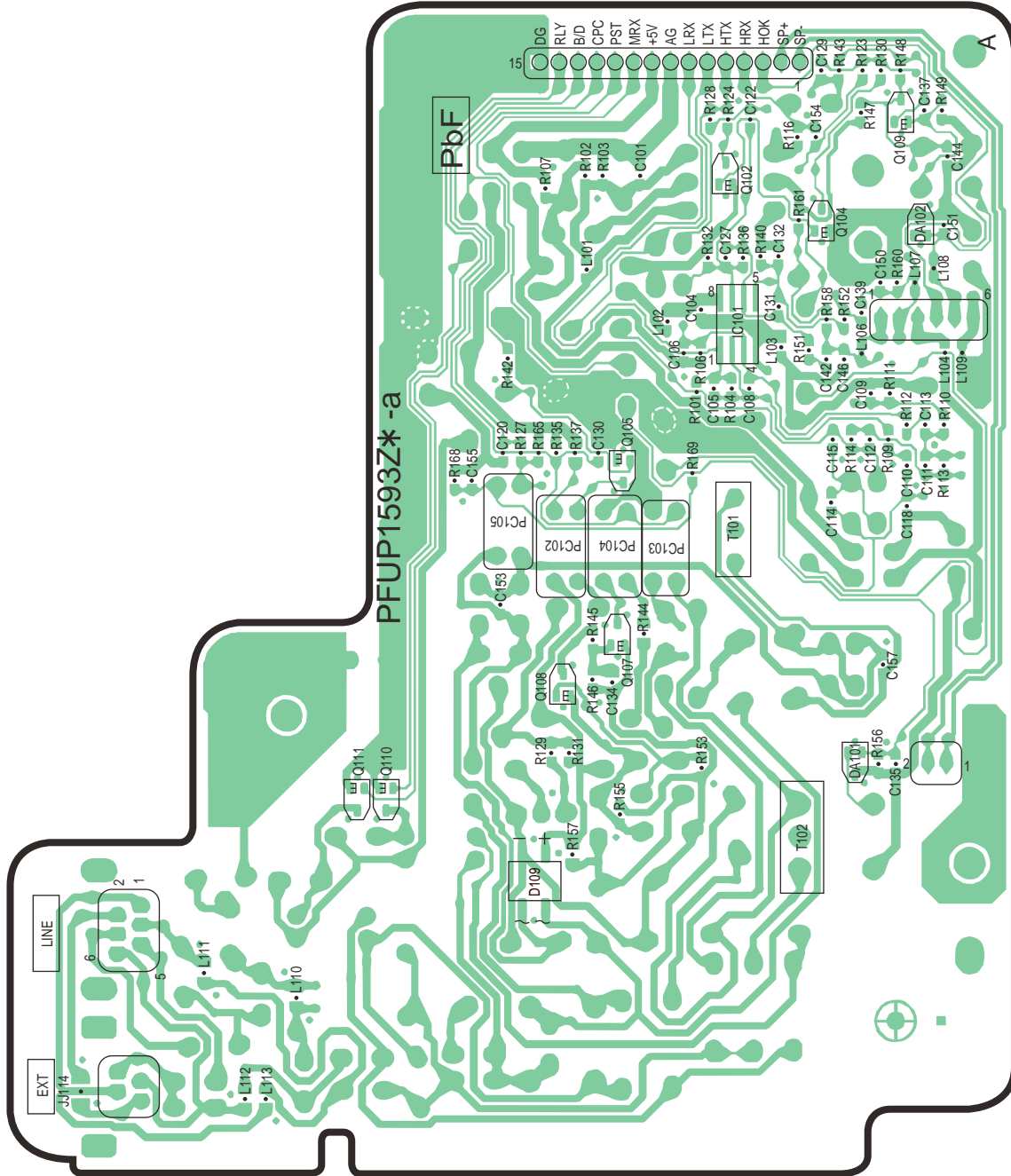

KX-FP207/218FX-S : ANALOG Board (Bottom View)

18.2.2. Component View

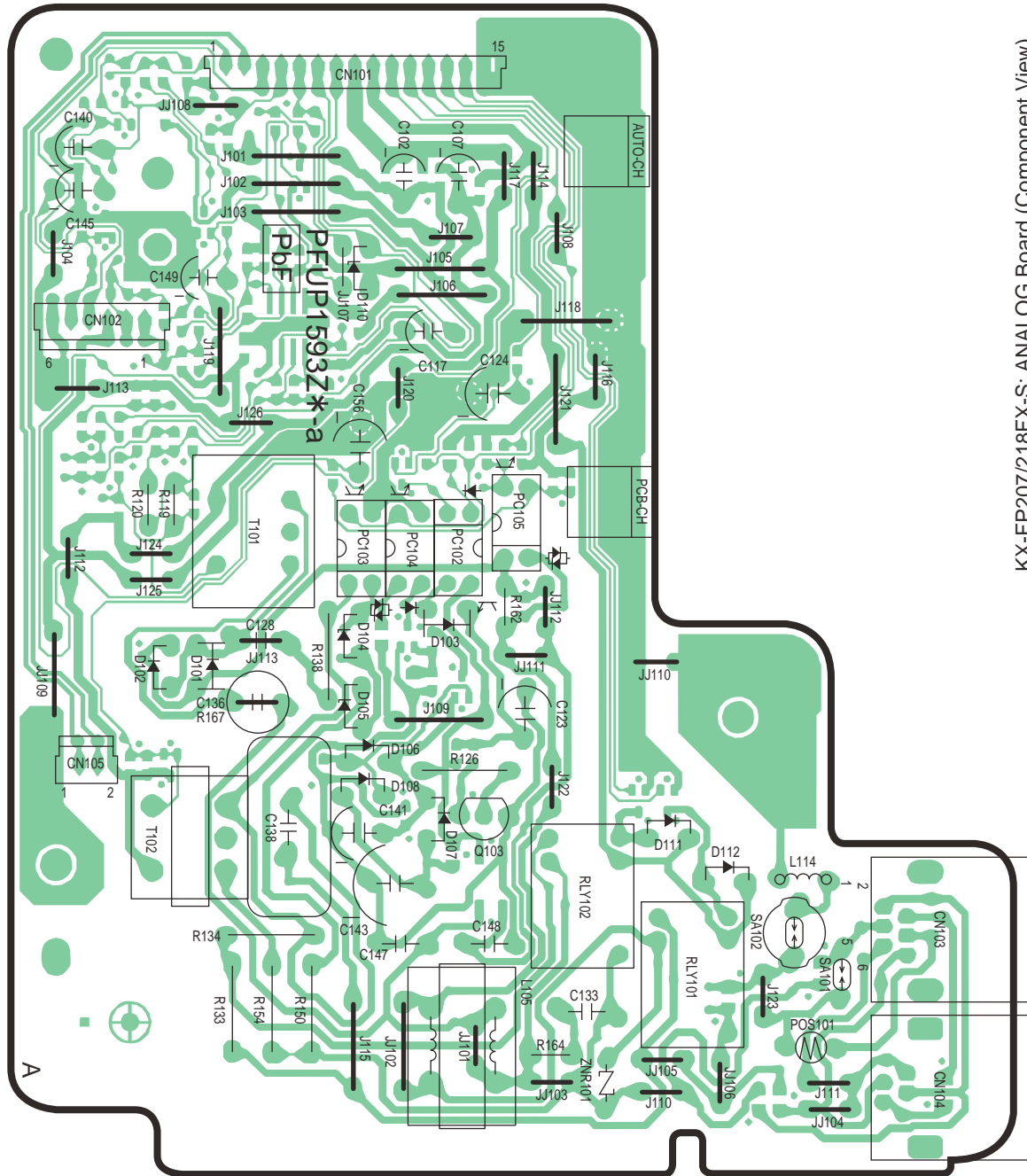

KX-FP207/218FX-S: ANALOG Board (Component View)

18.3. Operation Board (PCB3)

18.3.1. KX-FP207FX-S

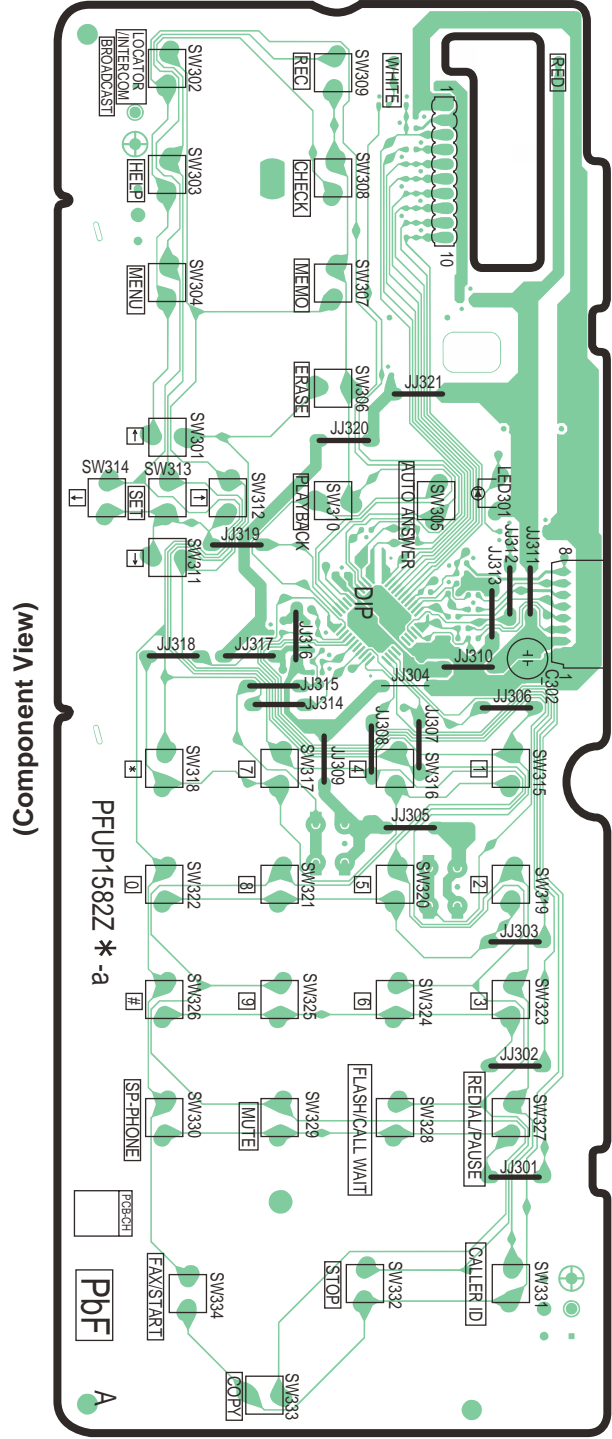
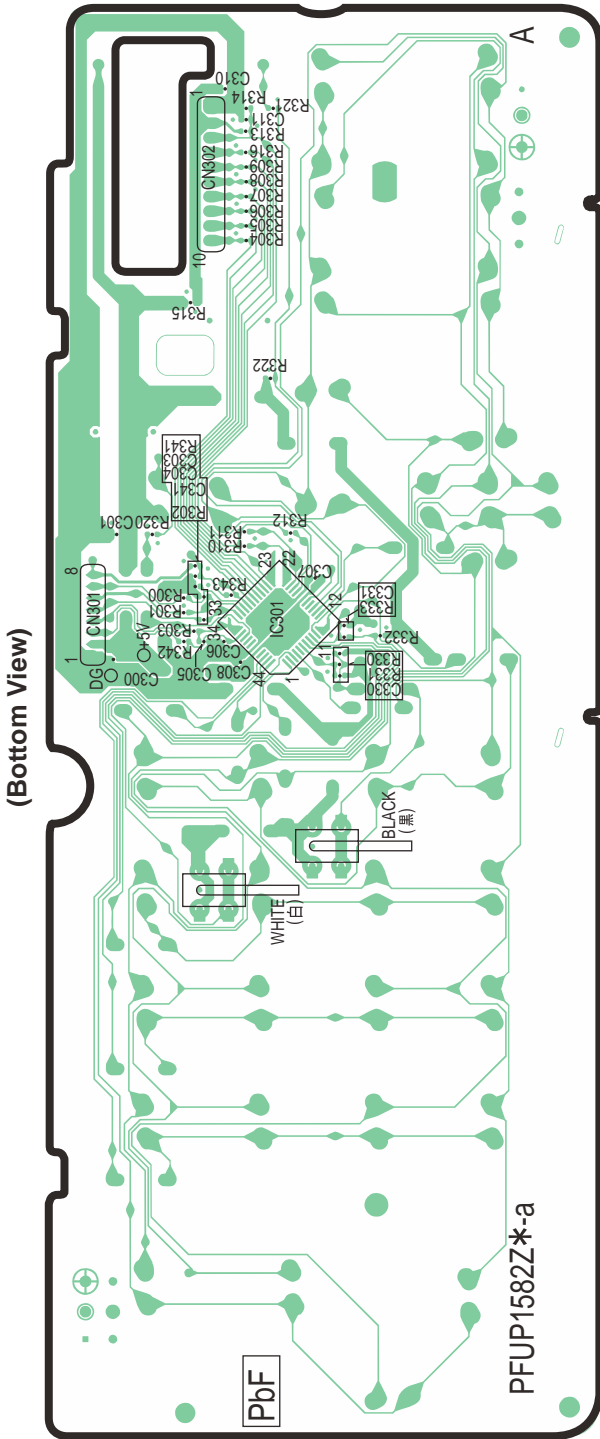

18.3.2. KX-FP218FX-S

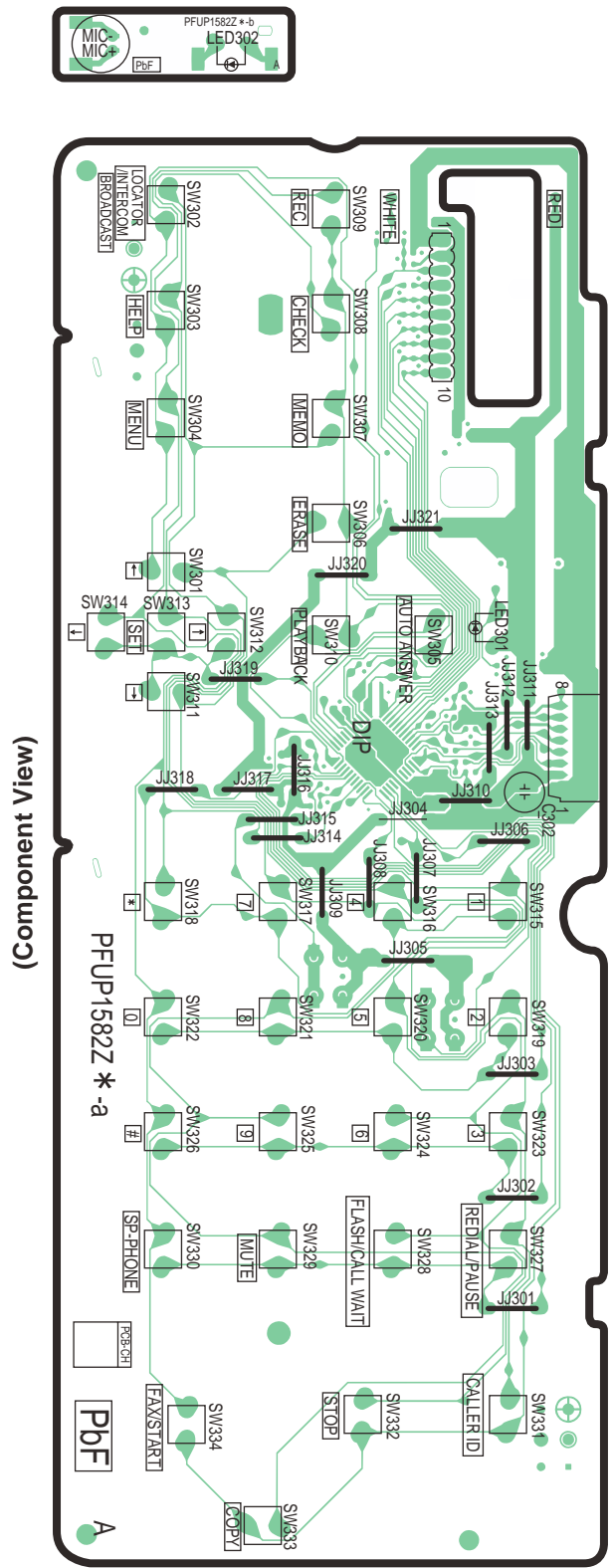
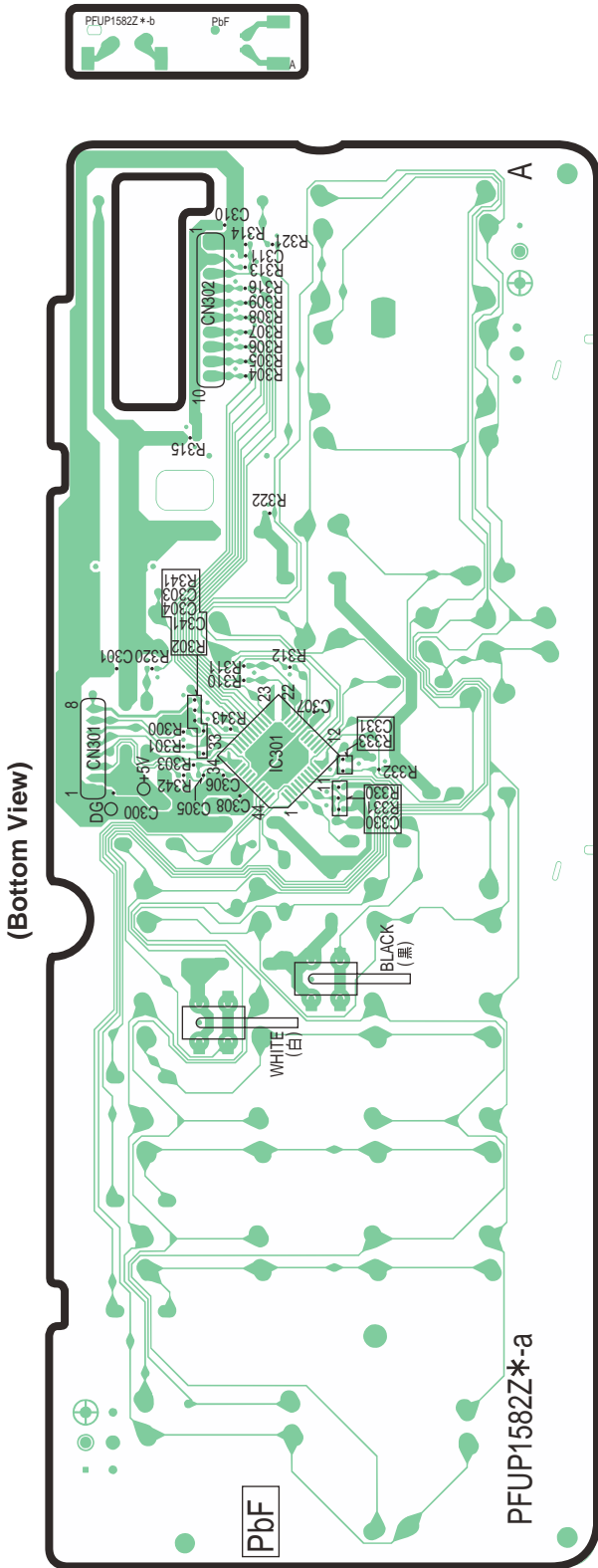

KX-FP218FX-S: Operation Board / MIC Board

18.4. Power Supply Board (PCB4)

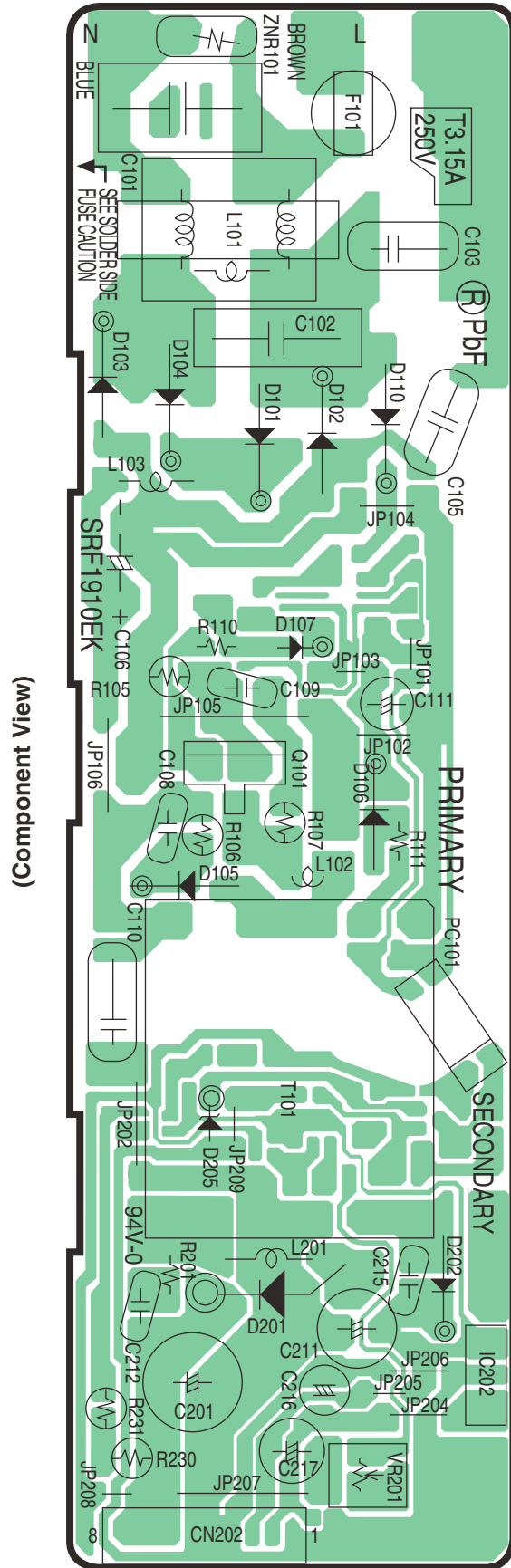
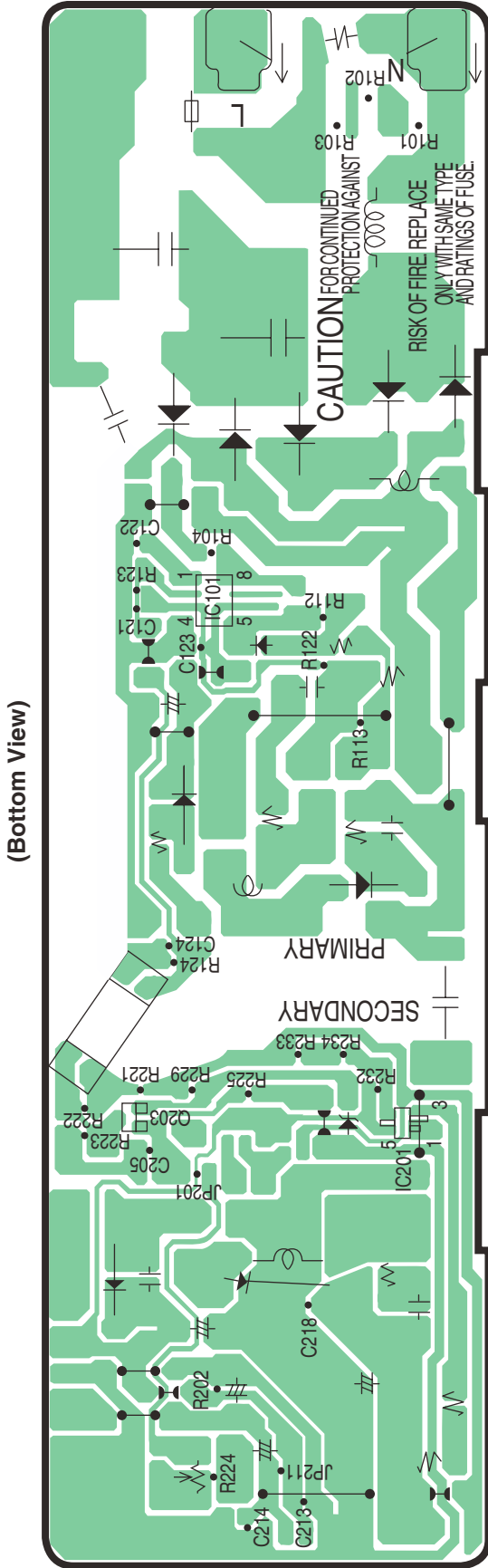

KX-FP207/218FX-S : Power Supply Board

18.5. Interface Board (PCB5)

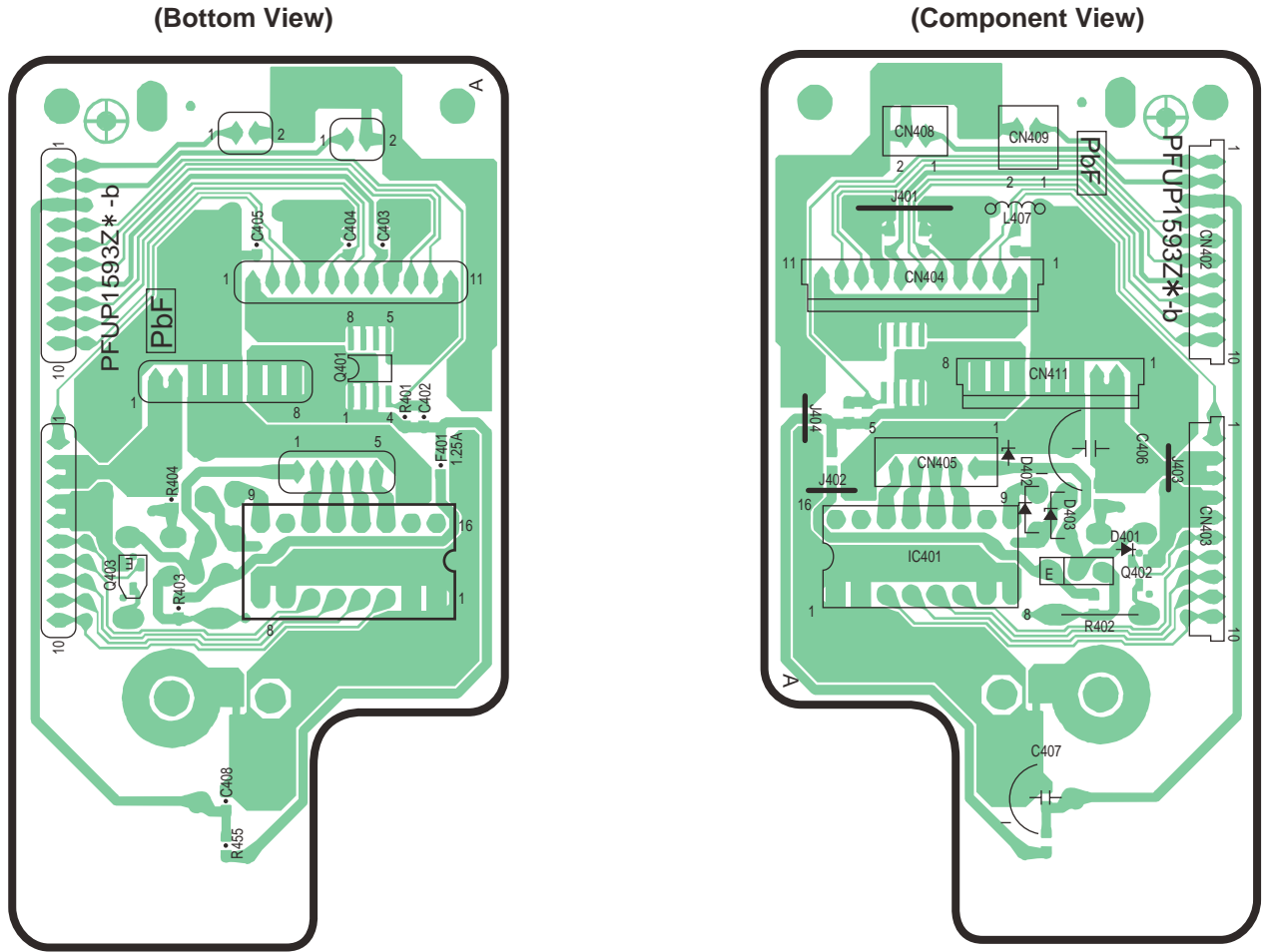

KX-FP207/218FX-S: Interface Board

18.6. Sensor Board (PCB6)

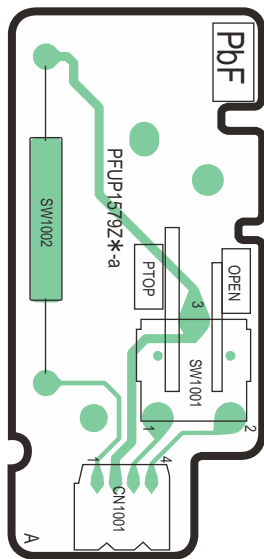

KX-FP207/218FX-S: Sensor Board

18.7. Film End Sensor Board (PCB7)

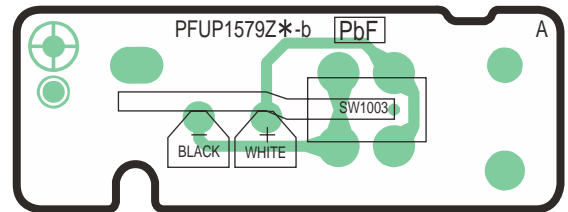

KX-FP207/218FX-S : Film End Sensor Board

18.8. Motor Position Sensor Board (PCB8)

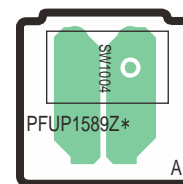

KX-FP207/218FX-S: Motor position Board

18.9. Hook Switch Board (PCB9)

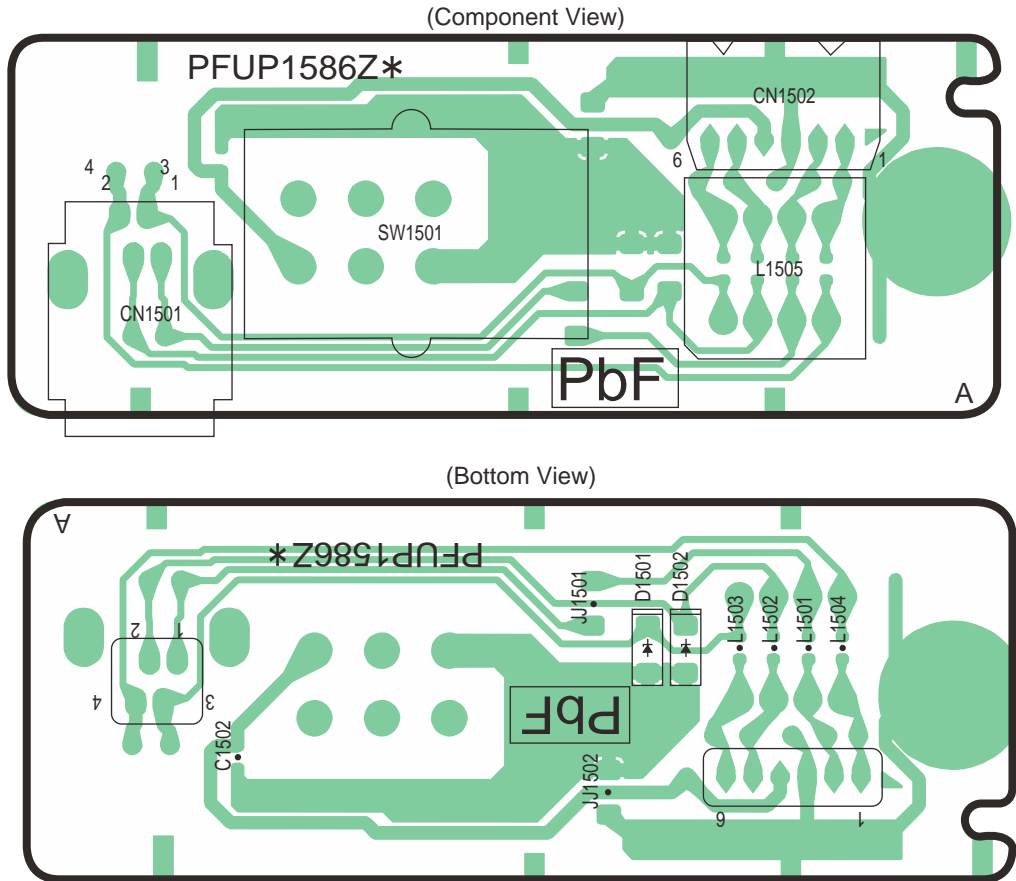

KX-FP207/218FX-S: Hook Switch Board

19 Appendix Information of Schematic Diagram

Note:

1. DC voltage measurements are taken with an oscilloscope or a tester with a ground.
2. The schematic diagrams and circuit board may be modified at any time with the development of new technology.

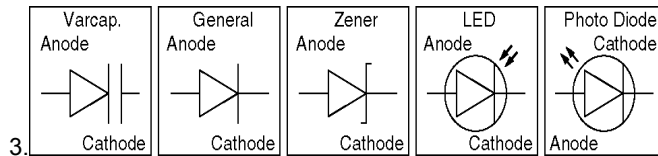

Important safety notice
 Components identified by \triangle mark have special characteristics important for safety. When replacing any of these components, use only the manufacturer's specified parts.

20 Exploded View and Replacement Parts List

20.1. Cabinet, Mechanical and Electrical Parts Location

20.1.1. General Section

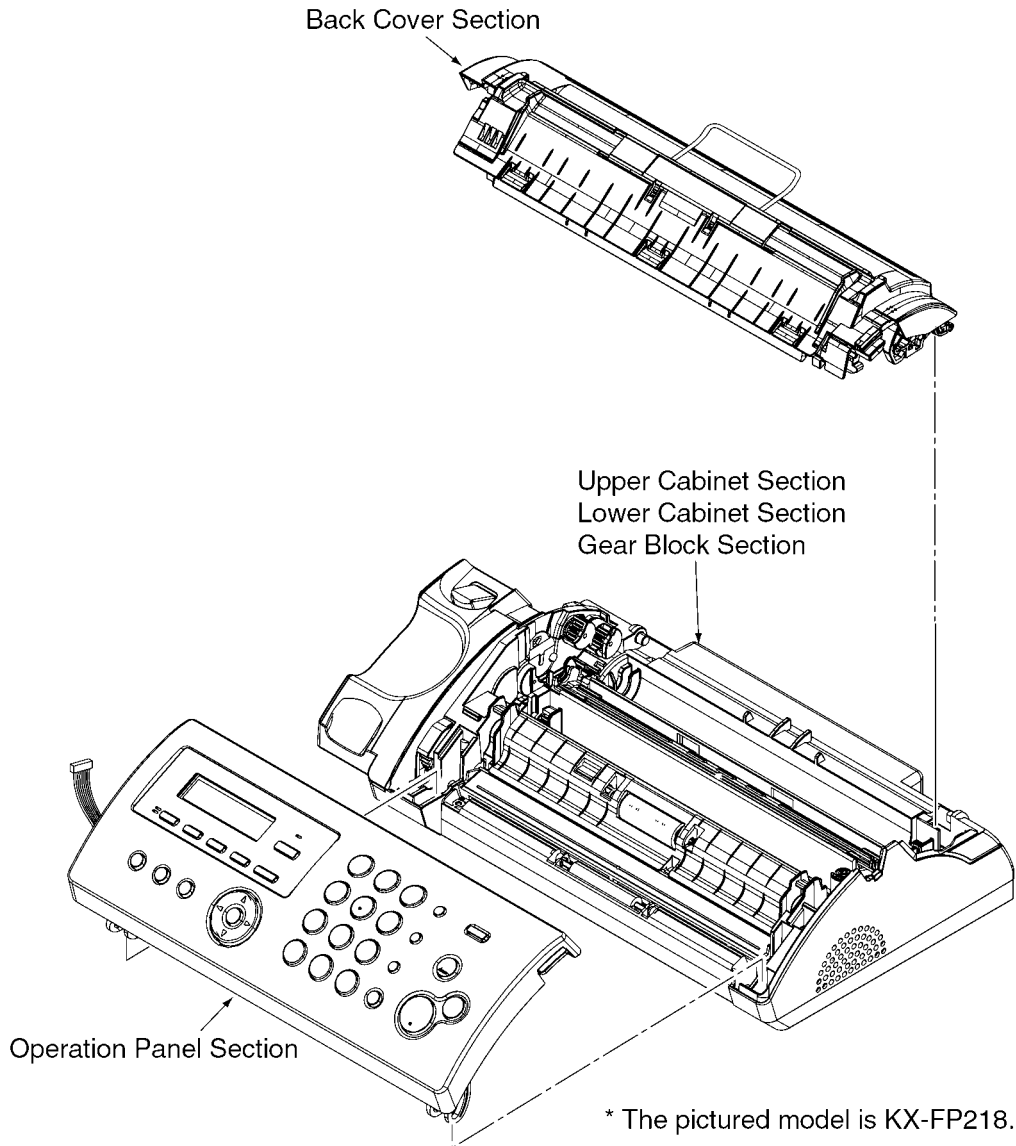

20.1.2. Operation Panel Section

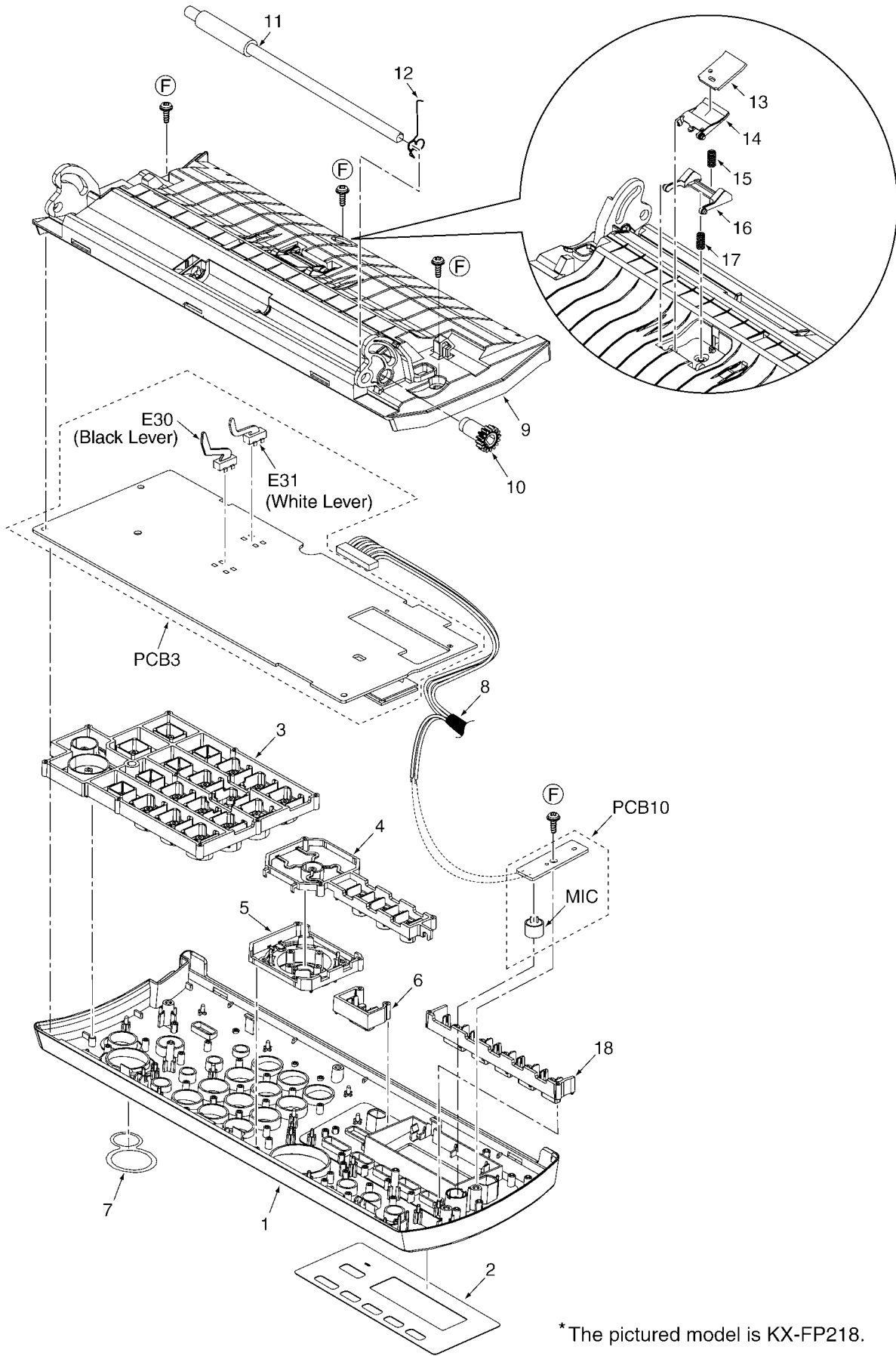

*The pictured model is KX-FP218.

20.1.3. Upper Cabinet Section

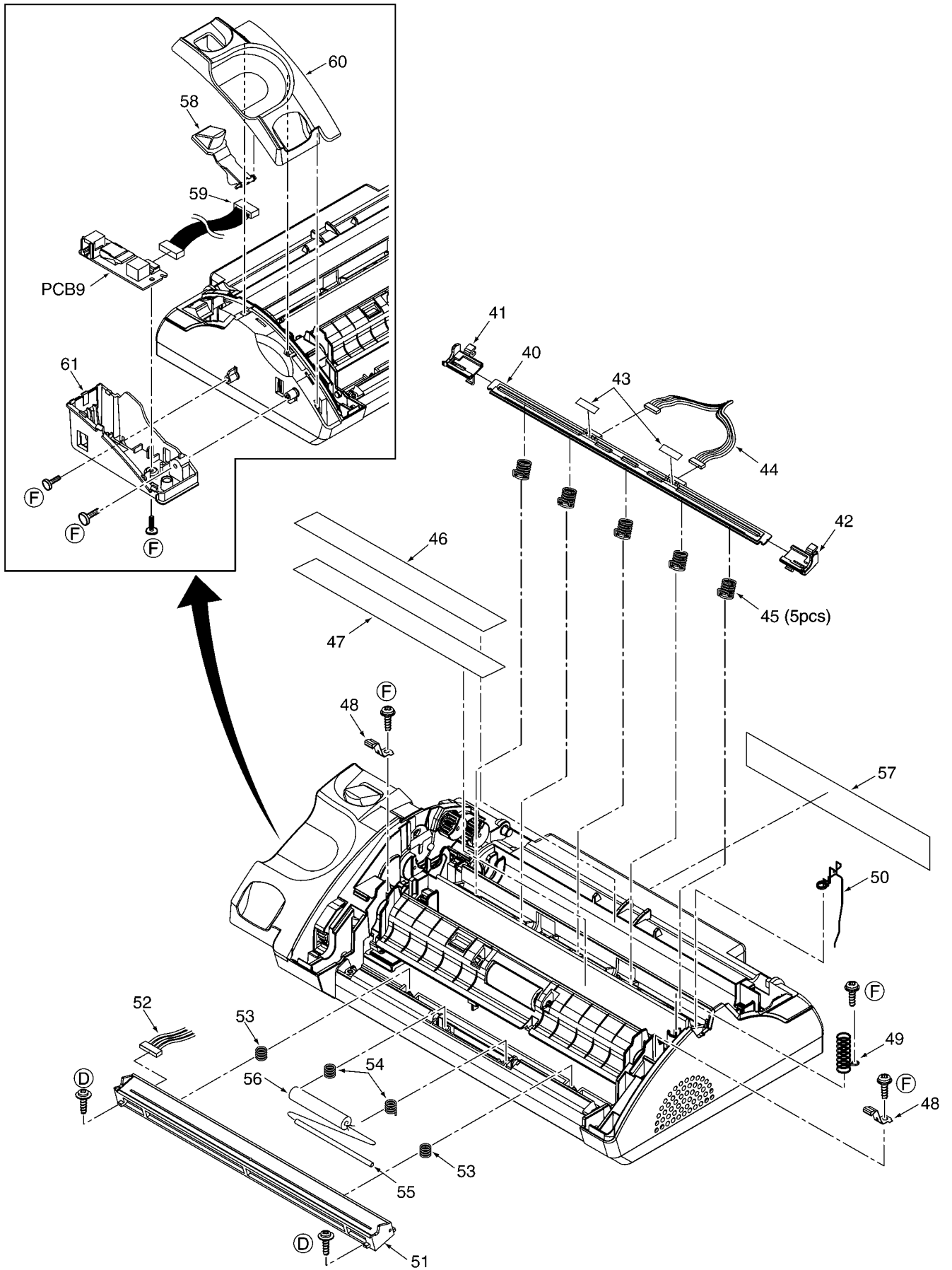

20.1.4. Back Cover Section

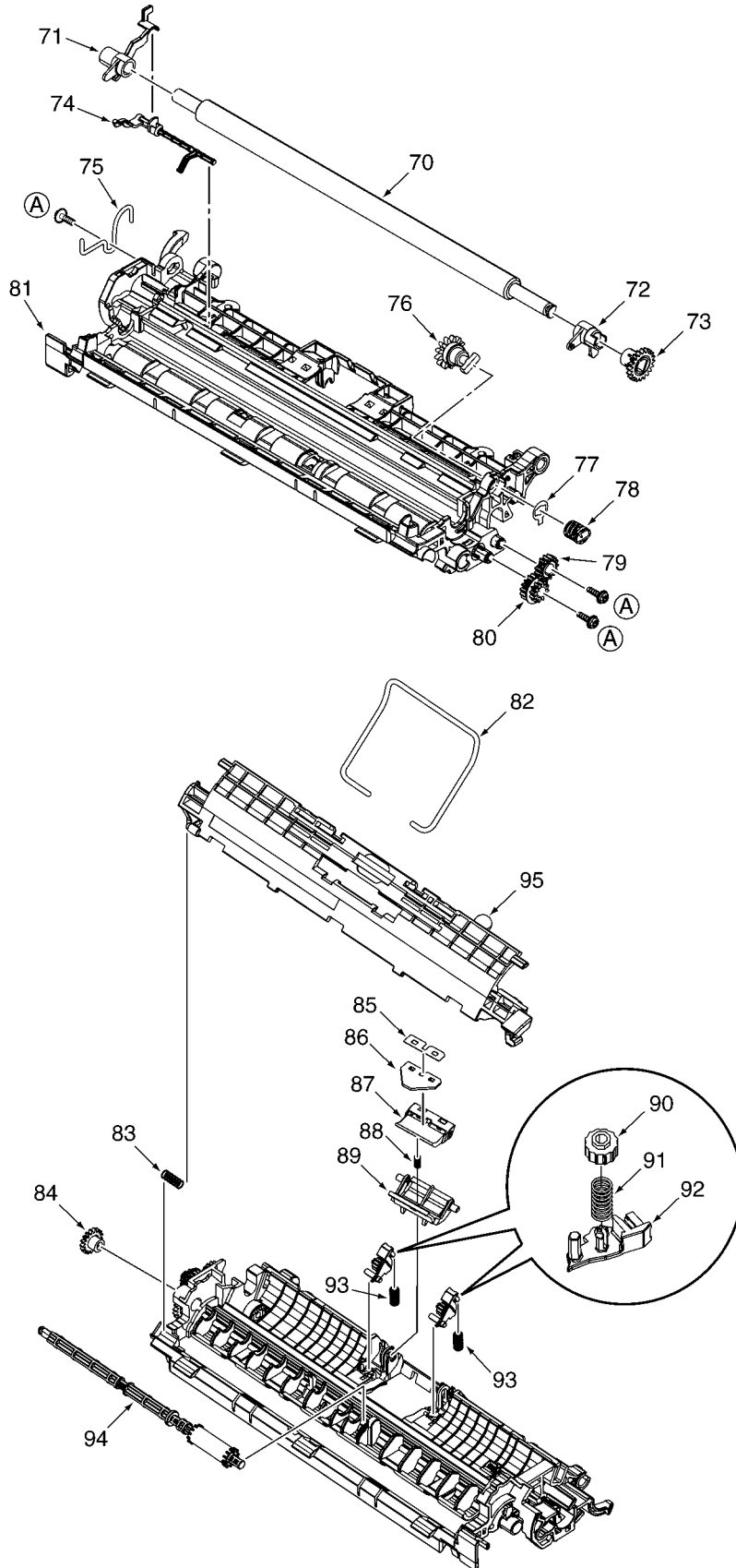

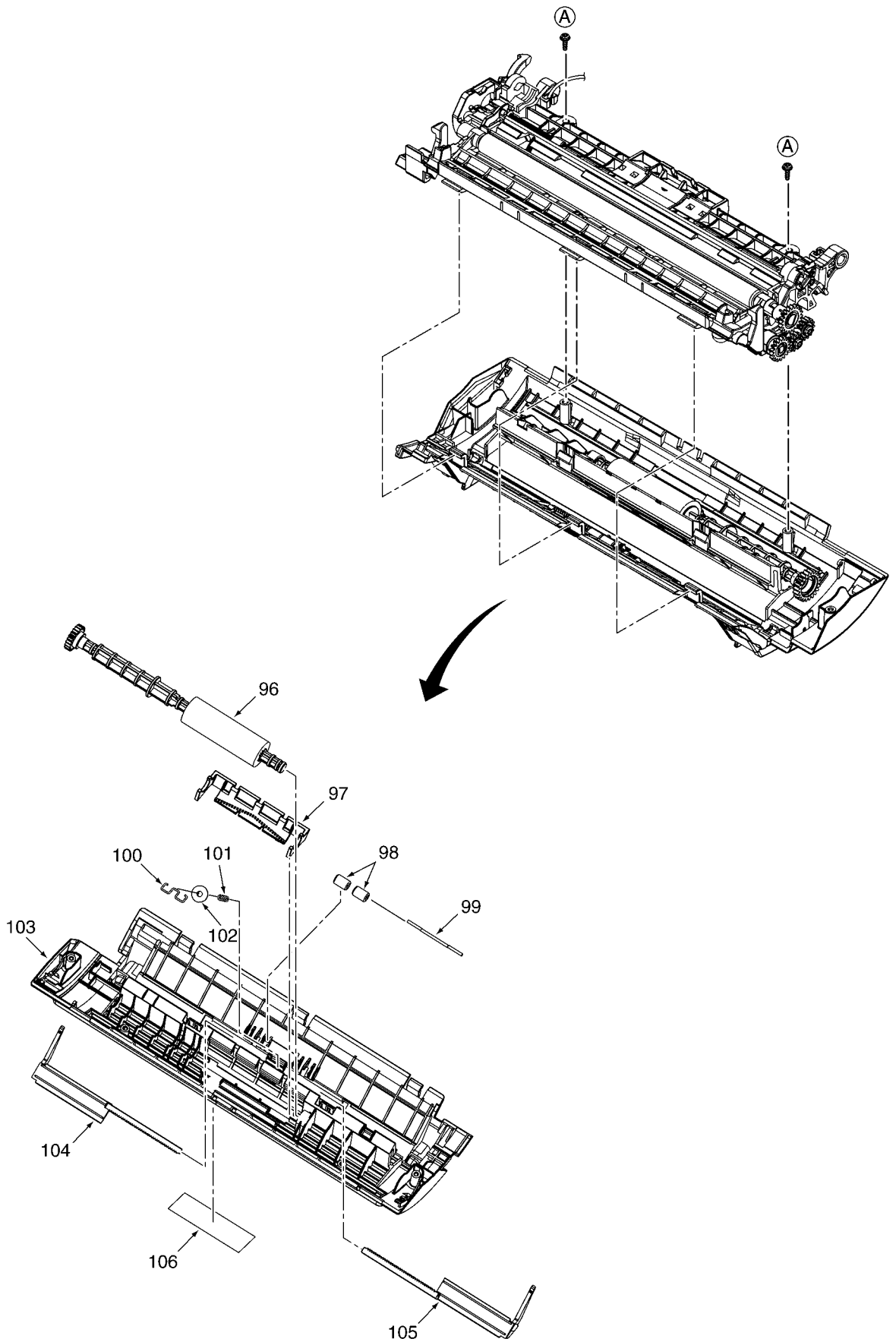

20.1.5. Lower Cabinet Section

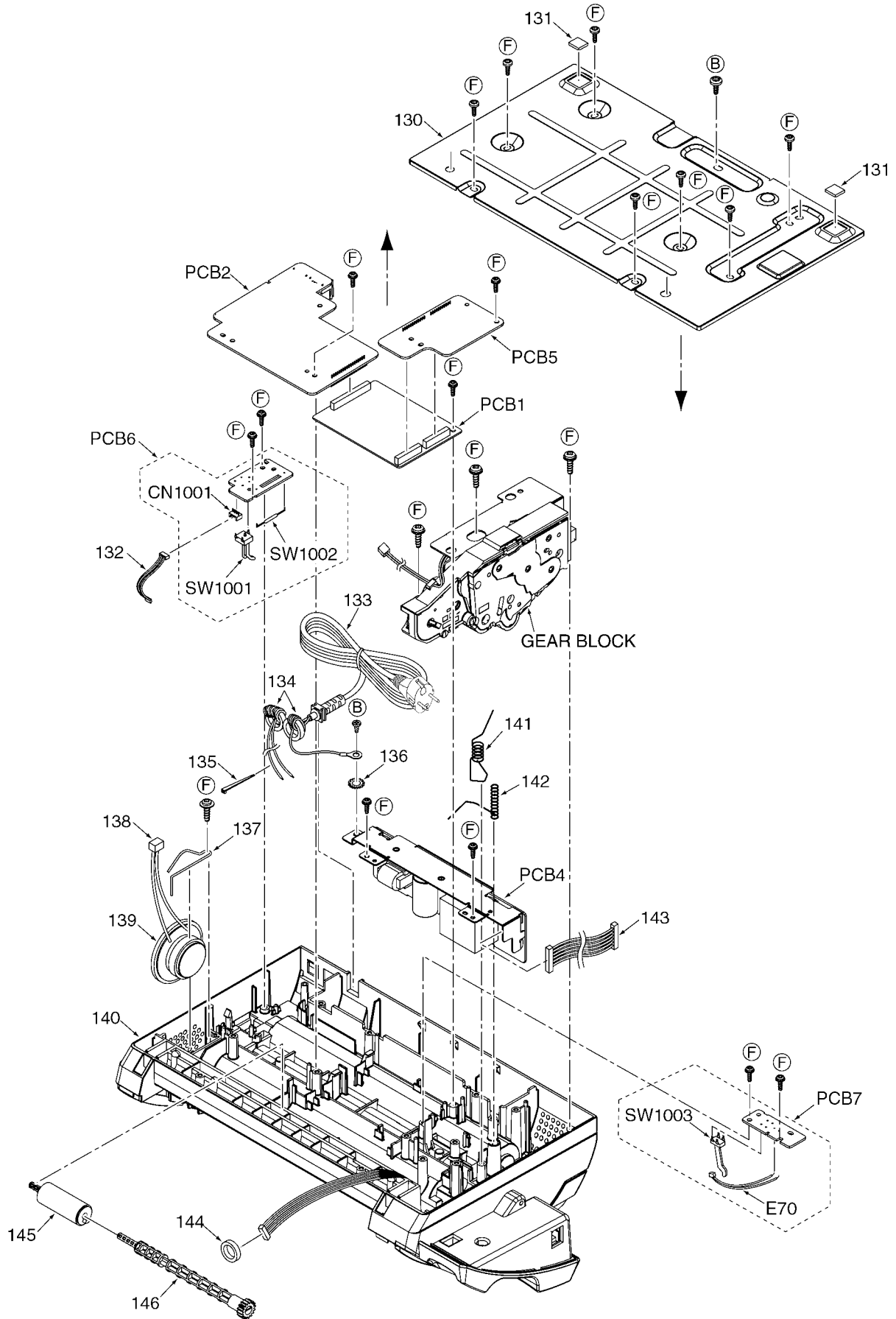



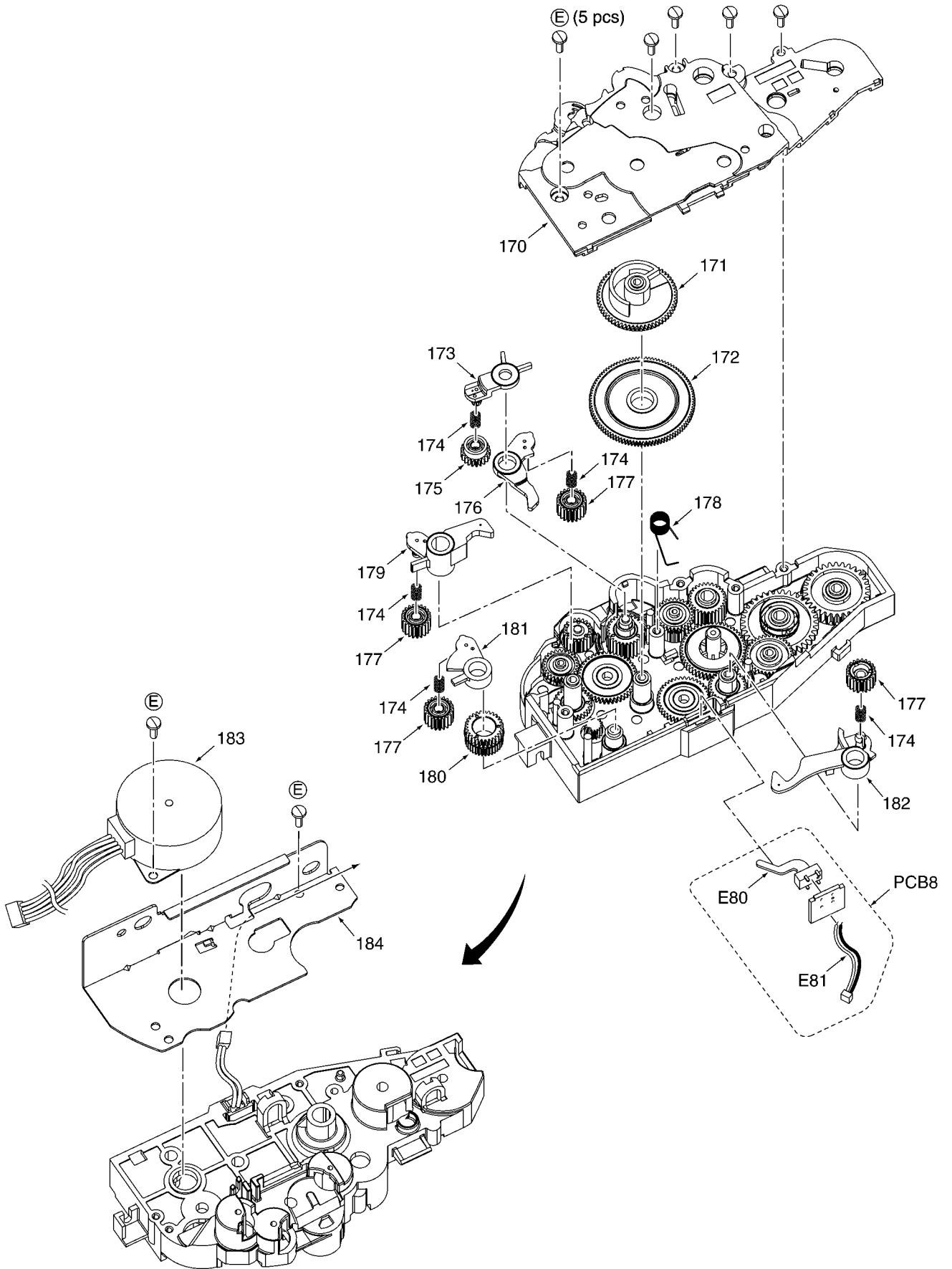

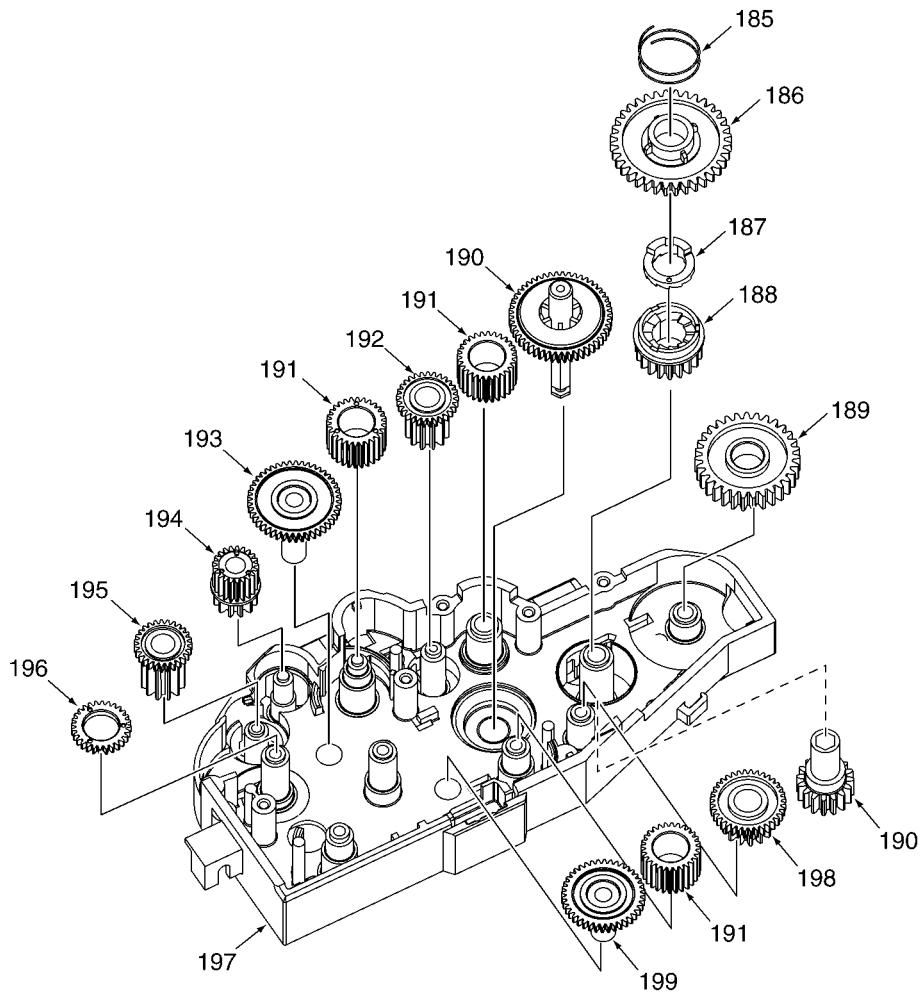
20.1.6. Gear Block Section



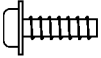

20.1.7. Screws

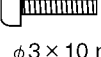
	Part No.	Figure
Ⓐ	XTW3+10PFJ7	 φ3 × 10 mm
Ⓑ	XSB4+6FJ	 φ4 × 6 mm
Ⓓ	XTW3+W8PFJ	 φ3 × 8 mm
Ⓔ	XTB26+8GFJ	 φ2.6 × 8 mm
Ⓕ	XTB3+10GFJ	 φ3 × 10 mm

20.1.8. Accessories and Packing Materials

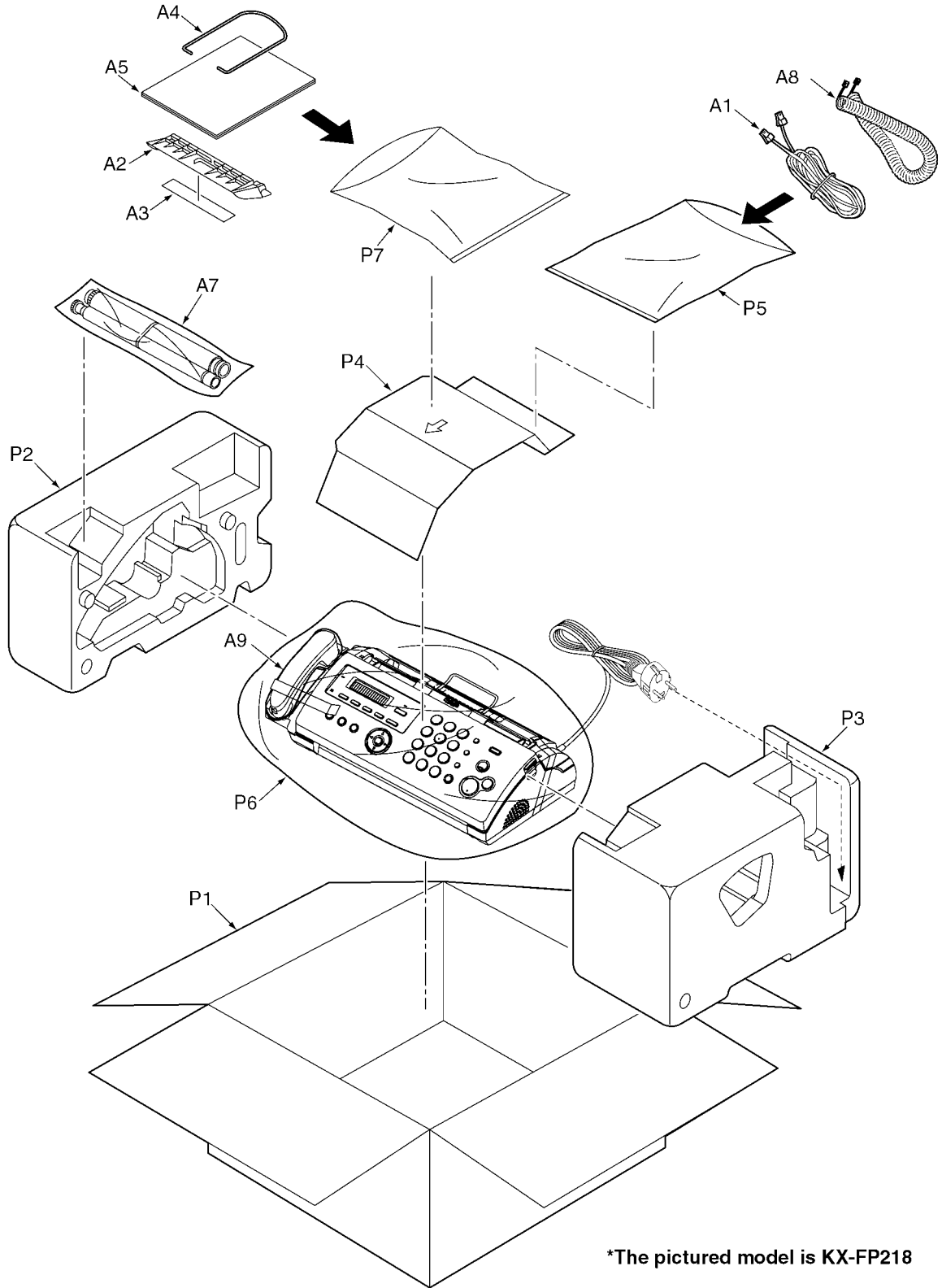

*The pictured model is KX-FP218

20.2. Replacement Parts List

Notes:

1. The marking (RTL) indicates that the Retention Time is limited for this item.

After the discontinuation of this assembly in production, the item will continue to be available for a specific period of time. The retention period of availability is dependent on the type of assembly, and in accordance with the laws governing parts and product retention.

After the end of this period, the assembly will no longer be available.

2. Important safety notice

Components identified by \triangle mark have special characteristics important for safety. When replacing any of these components, use only manufacture's specified parts.

3. The S mark means the part is one of some identical parts. For that reason, it may be different from the installed part.

4. RESISTORS & CAPACITORS

Unless otherwise specified;

All resistors are in ohms (Ω) K=1000 Ω , M=1000k Ω

All capacitors are in MICRO FARADS (μ F) P= μ μ F

*Type & Wattage of Resistor

Type

ERC:Solid	ERX:Metal Film	PQ4R:Carbon
ERD:Carbon	ERG:Metal Oxide	ERS:Fusible Resistor
PQRD:Carbon	ER0:Metal Film	ERF:Cement Resistor

Wattage

10,16:1/8W	14,25:1/4W	12:1/2W	1:1W	2:2W	3:3W
------------	------------	---------	------	------	------

*Type & Voltage of Capacitor

Type

ECFD:Semi-Conductor	ECCD,ECKD,ECBT,PQCBC : Ceramic
ECQS:Styrol	ECQE,ECQV,ECQG : Polyester
PQCUV:Chip	ECEA,ECSZ : Electrolytic
ECQMS:Mica	ECQP : Polypropylene

Voltage

ECQ Type	ECQG ECQV Type	ECSZ Type	Others	
1H: 50V	05: 50V	0F:3.15V	0J :.6.3V	1V :.35V
2A:100V	1:100V	1A:10V	1A :10V	50,1H:50V
2E:250V	2:200V	1V:35V	1C :16V	1J :.63V
2H:500V		0J:6.3V	1E,25:25V	2A :100V

20.2.1. Cabinet and Electrical Parts

20.2.1.1. Operation Panel Section

Ref. No.	Part No.	Part Name & Description	Remarks
1	PFGG1294M4	GRILLE (KX-FP207FX)	PS-HB
1	PFGG1299D4	GRILLE (KX-FP218FX)	PS-HB
2	PFGP1352Z	PANEL, LCD (KX-FP207FX)	PC
2	PFGP1370Z	PANEL, LCD (KX-FP218FX)	PC
3	PFBX1255Y1	BUTTON, 20 KEY	ABS-HB
4	PFBX1256Y1	BUTTON, 4 KEY	ABS-HB
5	PFBC1168Z1	BUTTON	ABS-HB
6	PFBC1169Z1	BUTTON	ABS-HB
7	PFHX1957Z1	SPACER, SHEET	PC
8	PFJS08M43Z	CONNECTOR, 8 PIN (KX-FP207FX)	
8	PFJS10M35Z	CONNECTOR, 10 PIN (KX-FP218FX)	
9	PFUV1103Z	COVER, OPERATION	PS-HB
10	PFDG1494Z	GEAR, DOC. EXIT	POM-HB
11	PFDR1089Y	ROLLER, EXIT	
12	PFUS1717Z	SPRING, DOC. EXIT EARTH	SUS
13	PFHG1249Z	SPACER, PAD (RUBBER)	
14	PFHR1573Z	COVER, SEPARATION HOLDER	ABS-HB
15	PFUS1712Z	COIL SPRING	SUS

Ref. No.	Part No.	Part Name & Description	Remarks
16	PFHR1575Z	SPACER, DOC. FEED SUPPORT	POM-HB
17	PFUS1713Z	COIL SPRING, DOC. FEED	SUS
18	PFBX1257Z1	BUTTON, 5 KEY (KX-FP218FX)	S

20.2.1.2. Upper Cabinet Section

Ref. No.	Part No.	Part Name & Description	Remarks
40	L1CC00000063	PRINTER UNITS, THERMAL HEAD	
41	PFHR1569X	GUIDE, HOLDER (LEFT)	POM-HB
42	PFHR1570Z	GUIDE, HOLDER (RIGHT)	POM-HB
43	PFHX1350Z	SPACER, SHEET	
44	PFJS11M16Z	CONNECTOR, 11 PIN	
45	PFUS1710Z	COIL SPRING	SUS
46	PFQT2708Z	LABEL, INK RIBBON SET	
47	PFQT2700Z	LABEL, INK RIBBON	
48	PFUS1699Z	LEAF SPRING	SUS
49	PFUS1708Z	COIL SPRING	SUS
50	PFUS1716Z	SPRING, LOCK EARTH	SUS
51	N2GZBE000013	IMAGE SENSOR (CIS)	
52	PFJS07M18Z	CONNECTOR, 7 PIN	
53	PFUS1494Z	SPRING, CIS	SUS
54	PFUS1756Z	COIL SPRING	SUS
55	PFDF1017Z	SHAFT	SUS
56	PFDR1045Z	ROLLER, DOC. SUB	POM-HB
57	PFGT3234Z-M	NAME PLATE, AL (KX-FP207FX)	
57	PFGT3235Z-M	NAME PLATE, AL (KX-FP218FX)	
58	PFBH1034Z1	BUTTON, HOOK SWITCH	ABS-HB
59	PFJS06M21Z	CONNECTOR, 6 PIN	
60	PFKE1058Z1	CABINET COVER, HANDSET CRADLE (Top)	PS-HB
61	PFKF1092Y1	CABINET COVER, HANDSET CRADLE (Bottom)	PS-HB

20.2.1.3. Back Cover Section

Ref. No.	Part No.	Part Name & Description	Remarks
70	PFDN1082Z	ROLLER, PLATEN	
71	PFHR1572Z	SPACER, HOLDER (RIGHT)	POM-HB
72	PFHR1571Z	SPACER, HOLDER (LEFT)	POM-HB
73	PFDG1368Z	GEAR	POM-HB
74	PFHR1574Z	LEVER, PAPER TOP	POM-HB
75	PFUS1743Z	TORSION SPRING	SUS
76	PFDG1518Z	GEAR	POM-HB
77	PFHX1968Z	SPACER, SHEET	
78	PFUS1740Z	COIL SPRING	SUS
79	PFDG1496Z	GEAR	POM-HB
80	PFDG1497Z	GEAR	POM-HB
81	PFUA1082Y	CHASSIS	PS-HB
82	PFUS1703Y	SPRING, RECORDING PAPER	SUS
83	PFUS1705Z	COIL SPRING	SUS
84	PFDG1365Z	GEAR	POM-HB
85	PFHX1757Z	COVER, SHEET	
86	PFHG1263Z	SPACER, SEPARATION RUBBER	
87	PFHR1446Z	COVER, SEPARATION HOLDER	ABS
88	PFUS1746Z	COIL SPRING	SUS
89	PFHR1567Z	CASE	PS-HB
90	PFDR1056Z	ROLLER	POM-HB
91	PFUS1540Z	COIL SPRING	SUS
92	PFHR1447Z	LEVER	POM-HB
93	PFUS1539Z	COIL SPRING	SUS
94	PFDR1088Z	ROLLER, DISCHARGE	POM-HB/ EPDM
95	PFKE1057Y2	LEVER, LOCK	ABS+GF2 0-HB
96	PFDR1087Z	ROLLER, PICKUP	POM/ EPDM
97	PFKV1142Z1	COVER, ROLLER	PS-HB
98	PFDR1057Z	ROLLER, SUPPORT	POM

Ref. No.	Part No.	Part Name & Description	Remarks
99	PFUS1706Z	BAR SPRING	SUS
100	PFUS1750Z	TORSION SPRING	SUS
101	PFUS1792Z	COIL SPRING	PS-HB
102	PFDG1015X	SPACER	POM-HB
103	PFK1143Y1	COVER	PS-HB
104	PFKR1100Z1	GUIDE, RIGHT	ABS-HB
105	PFKR1099Z1	GUIDE, LEFT	ABS-HB
106	PFQT2670Z	LABEL, SENDING	

20.2.1.4. Lower Cabinet Section

Ref. No.	Part No.	Part Name & Description	Remarks
130	PFMD1102Z	FRAME, BOTTOM	SECC
131	PFHG1050Z	RUBBER PART, LEG	PORON
132	PFJS04M36Z	CONNECTOR, 4 PIN	
133	PFJA03A016Z	POWER CORD	△
134	PQLB1E1	INSULATOR	S
135	PQHR945Z	BAND	
136	XWC4BFJ	WASHER	
137	PFUS1707Z	TORSION SPRING	SUS
138	PFJS02M17Z	CONNECTOR, 2 PIN	
139	PFAS50P006Z	SPEAKER	S
140	PFKM1194Y1	CABINET BODY (KX-FP207FX)	PS-V0
140	PFKM1194X1	CABINET BODY (KX-FP218FX)	PS-V0
141	PFUS1715Z	SPRING, PLATEN EARTH	SUS
142	PFUS1709Z	SPRING, HEAD EARTH	SUS
143	PFJS08M14Z	CONNECTOR, 8 PIN	
144	PQLB1E1	INSULATOR	S
145	PFDR1086Z	ROLLER, DOC. SEPARATION	POM-HB/EPDM
146	PFDF1151Z	SHAFT, SEPARATION	POM-HB

20.2.1.5. Gear Block Section

Ref. No.	Part No.	Part Name & Description	Remarks
170	PFUV1102Z	COVER	POM-HB
171	PFDG1491Z	GEAR	POM-HB
172	PFDG1478Z	GEAR	POM-HB
173	PFHR1578Z	ARM	POM-HB
174	PFUS1545Z	BAR SPRING	SUS
175	PFDG1485Z	GEAR	POM-HB
176	PFHR1579Z	ARM	POM-HB
177	PFDG1484Z	GEAR	POM-HB
178	PFUS1718Z	COIL SPRING	SUS
179	PFHR1577Z	ARM	POM-HB
180	PFDG1483Z	GEAR	POM-HB
181	PFHR1576Z	ARM	POM-HB
182	PFHR1580Z	ARM	POM-HB
183	L6HAYYYK0006	DC MOTOR	
184	PFMH1199Z	FRAME	SECC
185	PFUS1714Z	COIL SPRING	SUS
186	PFDG1492Z	GEAR	POM-HB
187	PFDE1289Z	SPACER	POM-HB
188	PFDG1493Z	GEAR	POM-HB
189	PFDG1490Z	GEAR	POM-HB
190	PFDX1075Z	GEAR	POM+SUS
191	PFDG1482Z	GEAR	POM-HB
192	PFDG1486Z	GEAR	POM-HB
193	PFDG1480Z	GEAR	POM-HB
194	PFDG1488Z	GEAR	POM-HB
195	PFDG1487Z	GEAR	POM-HB
196	PFDG1481Z	GEAR	POM-HB
197	PFUA1081Z	CHASSIS	ABS+PBT-V0
198	PFDG1489Z	GEAR	POM-HB
199	PFDG1479Z	GEAR	POM-HB

20.2.1.6. Accessories and Packing Materials

Ref. No.	Part No.	Part Name & Description	Remarks
A1	PFJA02B002Y	CORD, TELEPHONE	
A2	PFKS1145Z1	TRAY	ABS-HB
A3	PFQT2825Z	LABEL, PAPER SET	
A4	PFUS1704Z	SPRING, TRAY	SUS
A5	PFQX2515Z	INSTRUCTION BOOK	
A6		NOT USED	
A7	PFPE1511Z	INK RIBBON (10M)	PET
A8	PFJA04C003Z	CORD, HANDSET	
A9	PFJXN0430Y	HANDSET	
P1	PFZE1494Z-M	GIFT BOX (KX-FP207FX)	S
P1	PFZE1495Z-M	GIFT BOX (KX-FP218FX)	S
P2	PFPN1442Z	CUSHION, LEFT	EPS
P3	PFPN1443Z	CUSHION, RIGHT	EPS
P4	PFPD1303Z	ACCESSORY BOX, PAPER	
P5	XZB20X35A04	PROTECTION COVER	
P6	PFPH1085Z	PACKING SHEET	
P7	XZB32X45A04	PROTECTION COVER	

20.2.2. Digital Board Parts (KX-FP207FX)

Ref. No.	Part No.	Part Name & Description	Remarks
PCB1	PFWP1FP207FX	DIGITAL BOARD ASS'Y (RTL)	
		(ICs)	
IC501	C1ZBZ0003300	IC	
IC502	C0CBADD00009	IC	
IC503	C3ABKC000034	IC	
IC504	C0CBCBD00047	IC	
IC505	C1CB00001959	IC	
IC506	PFWIFP207FX	IC (ROM)	
IC508	C0JBAS000185	IC	
IC509	C0JBAA000393	IC	
IC510	C1AB00002556	IC	
IC511	C0ABEB000023	IC	
		(TRANSISTORS)	
Q501	B1GBCFGG0028	TRANSISTOR (SI)	
Q502	B1GBCFGG0028	TRANSISTOR (SI)	
Q503	B1ABDF000025	TRANSISTOR (SI)	
Q504	B1ABDF000025	TRANSISTOR (SI)	
Q505	B1ABDF000025	TRANSISTOR (SI)	
Q506	B1ABDF000026	TRANSISTOR (SI)	
Q508	2SB1218ARL	TRANSISTOR (SI)	
Q509	B1ABDF000025	TRANSISTOR (SI)	
Q510	B1ABDF000025	TRANSISTOR (SI)	
Q513	B1GBCFJJ0048	TRANSISTOR (SI)	
Q514	B1GBCFJJ0048	TRANSISTOR (SI)	
		(DIODE)	
D501	MA111	DIODE (SI)	S
		(BATTERY)	
BAT501	CR2032/H9B	BATTERY	!
		(CAPACITORS)	
C501	F2G0J4700032	47	
C502	ECJOEF1C104Z	0.1	
C503	ECJOEF1C104Z	0.1	
C505	ECJOEF1C104Z	0.1	
C507	ECJ1VF1A105Z	1	
C508	ECJOEB1H102K	0.001	
C509	ECJ1VF1A105Z	1	
C510	ECJOEB1H102K	0.001	
C511	F2G0J4700032	47	
C512	ECJOEB1A104K	0.1	
C513	ECJOEB1H102K	0.001	
C514	ECJOEB1H102K	0.001	
C516	ECJOEB1H102K	0.001	
C517	ECJOEF1C104Z	0.1	

Ref. No.	Part No.	Part Name & Description	Remarks
C518	ECJ0EF1C104Z	0.1	
C521	ECJ0EB1H102K	0.001	
C522	ECJ0EB1H222K	0.0022	
C523	ECJ0EF1C104Z	0.1	
C524	ECJ0EF1C104Z	0.1	
C525	ECJ0EC1H101J	100p	
C526	ECJ0EF1C104Z	0.1	
C527	ECJ0EF1C104Z	0.1	
C528	ECJ0EF1C104Z	0.1	
C529	ECJ0EF1C104Z	0.1	
C530	ECJ0EF1C104Z	0.1	
C531	ECJ0EF1C104Z	0.1	
C532	ECJ0EF1C104Z	0.1	
C533	ECJ0EF1C104Z	0.1	
C534	ECJ0EB1A104K	0.1	
C535	ECJ0EB1A104K	0.1	
C536	ECJ0EC1H100D	10p	
C538	ECJ0EF1C104Z	0.1	
C539	ECJ0EC1H150J	15p	
C540	ECJ0EF1C104Z	0.1	
C541	ECJ0EF1C104Z	0.1	
C542	ECJ0EF1C104Z	0.1	
C543	ECJ0EF1C104Z	0.1	
C544	ECJ0EF1C104Z	0.1	
C545	ECJ0EF1C104Z	0.1	
C546	ECJ0EB1H102K	0.001	
C548	ECJ0EF1C104Z	0.1	
C549	ECJ0EF1C104Z	0.1	
C550	ECJ0EF1C104Z	0.1	
C551	F2G0J4700032	47	
C553	ECJ0EF1C104Z	0.1	
C559	ECJ0EB1C103K	0.01	
C561	ECJ0EB1A104K	0.1	
C563	ECJ1VF1H104Z	0.1	
C564	ECJ0EF1C104Z	0.1	
C567	ECJ0EC1H560J	56p	
C568	ECJ1VF1H104Z	0.1	
C570	ECJ0EB1E472K	0.0047	
C573	F2G1C1000014	10	
C574	ECJ0EB1A273K	0.027	
C575	ECJ0EC1H101J	100p	
C578	ECJ0EB1H102K	0.001	
C580	ECJ0EB1C103K	0.01	
C582	ECJ0EF1C104Z	0.1	
C583	ECJ0EC1H330J	33p	
C584	ECJ0EB1H102K	0.001	
C586	ECJ0EF1C104Z	0.1	
C587	ECJ1VF1A105Z	1	
C588	ECJ0EB1A104K	0.1	
C589	ECUE1A104KBQ	0.1	S
C590	ECUE1A104KBQ	0.1	S
C591	ECJ0EF1C104Z	0.1	
C592	ECJ1VF1A105Z	1	
C594	ECJ0EB1C223K	0.022	
C595	ECJ1VB0J475K	4.7	
C596	ECJ0EC1H820J	82p	
C597	ECJ0EF1C104Z	0.1	
C598	ECJ0EF1C104Z	0.1	
C599	ECJ0EF1C104Z	0.1	
C600	ECJ0EC1H100D	10p	
C601	ECJ0EC1H120J	12p	
C602	ECJ0EF1C104Z	0.1	
C603	ECJ0EB1H102K	0.001	
C604	ECJ1VF1A105Z	1	
C605	ECJ0EC1H120J	12p	
C606	ECJ1VF1A105Z	1	
C607	ECJ0EF1C104Z	0.1	
C608	ECJ0EB1H102K	0.001	
C609	F2G1C1000014	10	
C611	ECJ0EC1H100D	10p	
C612	ECJ0EF1C104Z	0.1	
C613	ECUE1A104KBQ	0.1	S
C615	ECJ0EC1H181J	180p	

Ref. No.	Part No.	Part Name & Description	Remarks
C617	ECJ0EF1C104Z	0.1	
C623	ECJ0EB1A104K	0.1	
C624	ECJ0EF1C104Z	0.1	
C627	ECJ0EB1A104K	0.1	
C629	ECJ0EB1A104K	0.1	
C630	ECJ0EB1A104K	0.1	
C636	ECJ0EF1C104Z	0.1	
C637	ECJ0EB0J224K	0.22	
C638	ECJ0EB0J224K	0.22	
C648	ECJ0EB1H102K	0.001	
C649	F2G0J1010042	100	
C666	ECJ0EF1C104Z	0.1	
		(CONNECTORS)	
CN501	K1KA08A00440	CONNECTOR, 8 PIN	
CN502	K1KA10A00441	CONNECTOR, 10 PIN	
CN503	K1KA10A00441	CONNECTOR, 10 PIN	
CN504	K1KA04A00527	CONNECTOR, 4 PIN	
CN505	K1KA07A00257	CONNECTOR, 7 PIN	
CN507	K1KA15A00163	CONNECTOR, 15 PIN	
CN508	K1MN08A00017	CONNECTOR, 8 PIN	
		(COILS)	
L501	PQLQR2KA20T	COIL	S
L507	PQLQR2KA113	COIL	S
L512	PQLQR2KA113	COIL	S
L514	PQLQR2KA113	COIL	S
		(RESISTORS)	
R505	ERJ2GEJ101	100	
R507	ERJ2GEJ472X	4.7k	
R508	ERJ2GEJ472X	4.7k	
R509	ERJ2GEJ101	100	
R510	ERJ2GEJ472X	4.7k	
R513	ERJ3GEYJ333	33k	
R519	ERJ2GEJ101	100	
R521	ERJ2GEJ101	100	
R522	ERJ2GEJ101	100	
R523	ERJ2GEJ472X	4.7k	
R524	ERJ2GEJ101	100	
R526	ERJ3EKF1101	1.1k	
R527	ERJ3EKF3602	36k	
R528	ERJ3GEYJ220	22	
R529	ERJ2GEJ223	22k	
R530	ERJ2GEJ104	100k	
R531	ERJ2GEJ103	10k	
R532	ERJ2GEJ433	43k	
R533	ERJ2GEJ203	20k	
R534	ERJ2GEJ103	10k	
R535	ERJ2GEJ223	22k	
R536	ERJ2GEJ4R7	4.7	
R537	ERJ2GEJ222	2.2k	
R538	ERJ2GEJ182	1.8k	
R541	ERJ2GEJ334	330k	
R542	ERJ2GEJ475	4.7M	
R543	ERJ2GEJ222	2.2k	
R544	ERJ2GEJ471	470	
R545	ERJ2GEJ101	100	
R546	ERJ2GEJ101	100	
R547	ERJ2GEJ101	100	
R548	ERJ2GEJ101	100	
R550	ERJ2GEJ822	8.2k	
R551	ERJ2GEJ123	12k	
R552	ERJ2GEJ102	1k	
R555	ERJ2GEJ683	68k	
R556	ERJ2GEJ105X	1M	
R557	PQ4R10XJ100	10	S
R558	ERJ2GEJ332	3.3k	
R560	ERJ2GEJ221	220	
R561	ERJ2GEJ221	220	
R562	ERJ2GEJ472X	4.7k	
R564	ERJ2GEJ223	22k	
R565	ERJ2GEJ224	220k	
R566	ERJ2GEJ224	220k	
R567	ERJ2GEJ222	2.2k	
R568	ERJ2GEJ102	1k	

Ref. No.	Part No.	Part Name & Description	Remarks
R570	ERJ2GEJ684	680k	
R572	ERJ2GEJ273X	27k	
R574	ERJ2GEJ185	1.8M	
R575	ERJ2GEJ103	10k	
R577	ERJ2GEJ473	47k	
R580	ERJ2GEJ335	3.3M	
R581	ERJ2GEJ472X	4.7k	
R583	ERJ2GEJ683	68k	
R587	ERJ2GEJ273X	27k	
R588	ERJ2GEJ333	33k	
R589	ERJ2GEJ153	15k	
R590	ERJ2GEJ332	3.3k	
R591	ERJ2GEJ222	2.2k	
R593	ERJ2GEJ224	220k	
R594	ERJ2GEJ101	100	
R595	ERJ2GEJ181	180	
R596	ERJ2GEJ103	10k	
R597	ERJ2GEJ103	10k	
R601	ERJ2GEJ473	47k	
R602	ERJ2GEJ101	100	
R603	ERJ2GEJ272	2.7k	
R604	ERJ2GEJ124	120k	
R606	PQ4R18XJ220	22	S
R607	ERJ2GEJ124	120k	
R608	ERJ2GEJ334	330k	
R609	ERJ2GEJ473	47k	
R613	ERJ2GEJ563	56k	
R614	ERJ2GEJ682	6.8k	
R617	ERJ2GEJ473	47k	
R622	ERJ2GEJ332	3.3k	
R624	ERJ2GEJ472X	4.7k	
R626	ERJ2GEJ332	3.3k	
R627	ERJ2GEJ272	2.7k	
R628	ERJ2GEJ102	1k	
R633	ERJ2GEJ472X	4.7k	
R638	ERJ2GEJ472X	4.7k	
R554	ERJ2GEOR00	0	
R569	ERJ2GEOR00	0	
R598	ERJ2GEOR00	0	
R618	ERJ2GEOR00	0	
R637	ERJ2GEOR00	0	
R506	ERJ2GEOR00	0	
L504	ERJ3GEYOR00	0	
J503	ERJ2GEOR00	0	
J504	ERJ2GEOR00	0	
		(COMPONENTS PARTS)	
RA501	EXB38V103JV	RESISTOR ARRAY	
RA502	EXB28V101JX	RESISTOR ARRAY	
RA503	EXB28V101JX	RESISTOR ARRAY	
RA504	D1H84724A013	RESISTOR ARRAY	S
		(CRYSTAL OSCILLATORS)	
X501	H0A327200147	CRYSTAL OSCILLATOR	
X502	H2C240500006	CRYSTAL OSCILLATOR	
X503	H0J322500006	CRYSTAL OSCILLATOR	

20.2.3. Digital Board Parts (KX-FP218FX)

Ref. No.	Part No.	Part Name & Description	Remarks
PCB1	PFWP1FP218FX	DIGITAL BOARD ASS'Y (RTL)	
		(ICs)	
IC501	C1ZBZ0003300	IC	
IC502	C0CBADD00009	IC	
IC503	C3ABKC000034	IC	
IC504	C0CBCBD00047	IC	
IC505	C1CB00002325	IC	
IC506	PFWIFP218FX	IC (ROM)	
IC507	C3FBKC000135	IC	
IC508	C0JBAS000185	IC	
IC509	C0JBAA000393	IC	
IC510	C1AB00002556	IC	
IC511	C0ABEB000023	IC	
IC512	C0JBAE000333	IC	

Ref. No.	Part No.	Part Name & Description	Remarks
		(TRANSISTORS)	
Q501	B1GBCFGG0028	TRANSISTOR (SI)	
Q502	B1GBCFGG0028	TRANSISTOR (SI)	
Q503	B1ABDF000025	TRANSISTOR (SI)	
Q504	B1ABDF000025	TRANSISTOR (SI)	
Q505	B1ABDF000025	TRANSISTOR (SI)	
Q506	B1ABDF000026	TRANSISTOR (SI)	
Q508	2SB1218ARL	TRANSISTOR (SI)	
Q509	B1ABDF000025	TRANSISTOR (SI)	
Q510	B1ABDF000025	TRANSISTOR (SI)	
Q513	B1GBCFJJ0048	TRANSISTOR (SI)	
Q514	B1GBCFJJ0048	TRANSISTOR (SI)	
Q515	B1ABDF000026	TRANSISTOR (SI)	
		(DIODE)	
D501	MA111	DIODE (SI)	S
		(BATTERY)	
BAT501	CR2032/H9B	BATTERY	!
		(CAPACITORS)	
C501	F2G0J4700032	47	
C502	ECJOEF1C104Z	0.1	
C503	ECJOEF1C104Z	0.1	
C505	ECJOEF1C104Z	0.1	
C507	ECJ1VF1A105Z	1	
C508	ECJOEB1H102K	0.001	
C509	ECJ1VF1A105Z	1	
C510	ECJOEB1H102K	0.001	
C511	F2G0J4700032	47	
C512	ECJOEB1A104K	0.1	
C513	ECJOEB1H102K	0.001	
C514	ECJOEB1H102K	0.001	
C516	ECJOEB1H102K	0.001	
C517	ECJOEF1C104Z	0.1	
C518	ECJOEF1C104Z	0.1	
C521	ECJOEB1H102K	0.001	
C522	ECJOEB1H222K	0.0022	
C523	ECJOEF1C104Z	0.1	
C524	ECJOEF1C104Z	0.1	
C525	ECJOEC1H101J	100p	
C526	ECJOEF1C104Z	0.1	
C527	ECJOEF1C104Z	0.1	
C528	ECJOEF1C104Z	0.1	
C529	ECJOEF1C104Z	0.1	
C530	ECJOEF1C104Z	0.1	
C531	ECJOEF1C104Z	0.1	
C532	ECJOEF1C104Z	0.1	
C533	ECJOEF1C104Z	0.1	
C534	ECJOEB1A104K	0.1	
C535	ECJOEB1A104K	0.1	
C536	ECJOEC1H100D	10p	
C538	ECJOEF1C104Z	0.1	
C539	ECJOEC1H150J	15p	
C540	ECJOEF1C104Z	0.1	
C541	ECJOEF1C104Z	0.1	
C542	ECJOEF1C104Z	0.1	
C543	ECJOEF1C104Z	0.1	
C544	ECJOEF1C104Z	0.1	
C545	ECJOEF1C104Z	0.1	
C546	ECJOEB1H102K	0.001	
C548	ECJOEF1C104Z	0.1	
C549	ECJOEF1C104Z	0.1	
C550	ECJOEF1C104Z	0.1	
C551	F2G0J4700032	47	
C553	ECJOEF1C104Z	0.1	
C556	ECJOEF1C104Z	0.1	
C559	ECJOEB1C103K	0.01	
C561	ECJOEB1A104K	0.1	
C563	ECJ1VF1H104Z	0.1	
C564	ECJOEF1C104Z	0.1	
C567	ECJOEC1H560J	56p	
C568	ECJ1VF1H104Z	0.1	
C570	ECJOEB1E472K	0.0047	
C573	F2G1C1000014	10	
C574	ECJOEB1A273K	0.027	

Ref. No.	Part No.	Part Name & Description	Remarks
C575	ECJOEC1H101J	100p	
C578	ECJOEB1H102K	0.001	
C580	ECJOEB1C103K	0.01	
C581	ECJOEB1E472K	0.0047	
C582	ECJOEF1C104Z	0.1	
C583	ECJOEC1H330J	33p	
C586	ECJOEF1C104Z	0.1	
C587	ECJ1VF1A105Z	1	
C588	ECJOEB1A104K	0.1	
C589	ECUE1A104KBQ	0.1	S
C590	ECUE1A104KBQ	0.1	S
C591	ECJOEF1C104Z	0.1	
C592	ECJ1VF1A105Z	1	
C594	ECJOEB1C223K	0.022	
C595	ECJ1VB0J475K	4.7	
C596	ECJOEC1H820J	82p	
C597	ECJOEF1C104Z	0.1	
C598	ECJOEF1C104Z	0.1	
C599	ECJOEF1C104Z	0.1	
C600	ECJOEC1H100D	10p	
C601	ECJOEC1H120J	12p	
C602	ECJOEF1C104Z	0.1	
C603	ECJOEB1H102K	0.001	
C604	ECJ1VF1A105Z	1	
C605	ECJOEC1H120J	12p	
C606	ECJ1VF1A105Z	1	
C607	ECJOEF1C104Z	0.1	
C608	ECJOEB1H102K	0.001	
C609	F2G1C1000014	10	
C611	ECJOEC1H100D	10p	
C612	ECJOEF1C104Z	0.1	
C613	ECUE1A104KBQ	0.1	S
C615	ECJOEC1H181J	180p	
C617	ECJOEF1C104Z	0.1	
C622	ECJOEB1A104K	0.1	
C623	ECJOEB1A104K	0.1	
C624	ECJOEF1C104Z	0.1	
C626	ECJOEF1C104Z	0.1	
C627	ECJOEB1A104K	0.1	
C629	ECJOEB1A104K	0.1	
C630	ECJOEB1A104K	0.1	
C632	ECJOEB1A104K	0.1	
C633	ECJOEB1A104K	0.1	
C636	ECJOEF1C104Z	0.1	
C637	ECJOEB0J224K	0.22	
C638	ECJOEB0J224K	0.22	
C639	ECJOEF1C104Z	0.1	
C642	ECJOEF1C104Z	0.1	
C646	ECJOEF1C104Z	0.1	
C648	ECJOEB1H102K	0.001	
C649	F2G0J1010042	100	
C650	ECJOEC1H181J	180p	
C651	ECJOEB1C103K	0.01	
C652	ECJOEB1C103K	0.01	
C653	ECUV0J106KB	10	
C666	ECJOEF1C104Z	0.1	
C667	ECJOEF1C104Z	0.1	
		(CONNECTORS)	
CN501	K1KA08A00440	CONNECTOR, 8 PIN	
CN502	K1KA10A00441	CONNECTOR, 10 PIN	
CN503	K1KA10A00441	CONNECTOR, 10 PIN	
CN504	K1KA04A00527	CONNECTOR, 4 PIN	
CN505	K1KA07A00257	CONNECTOR, 7 PIN	
CN507	K1KA15A00163	CONNECTOR, 15 PIN	
CN508	K1MN08A00017	CONNECTOR, 8 PIN	
CN509	K1KA02A00587	CONNECTOR, 2 PIN	
		(COILS)	
L501	PQLQR2KA20T	COIL	S
L507	PQLQR2KA113	COIL	S
L512	PQLQR2KA113	COIL	S
L514	PQLQR2KA113	COIL	S
		(RESISTORS)	
R505	ERJ2GEJ101	100	

Ref. No.	Part No.	Part Name & Description	Remarks
R507	ERJ2GEJ472X	4.7k	
R508	ERJ2GEJ472X	4.7k	
R509	ERJ2GEJ101	100	
R510	ERJ2GEJ472X	4.7k	
R511	ERJ2GEJ564	560k	
R512	ERJ2GEJ332	3.3k	
R513	ERJ3GEYJ333	33k	
R514	ERJ2GEJ393X	39k	
R515	ERJ2GEJ222	2.2k	
R516	ERJ2GEJ151	150	
R519	ERJ2GEJ101	100	
R521	ERJ2GEJ101	100	
R522	ERJ2GEJ101	100	
R523	ERJ2GEJ472X	4.7k	
R524	ERJ2GEJ101	100	
R526	ERJ3EKF1101	1.1k	
R527	ERJ3EKF3602	36k	
R528	ERJ3GEYJ220	22	
R529	ERJ2GEJ223	22k	
R530	ERJ2GEJ104	100k	
R531	ERJ2GEJ103	10k	
R532	ERJ2GEJ433	43k	
R533	ERJ2GEJ203	20k	
R534	ERJ2GEJ103	10k	
R535	ERJ2GEJ223	22k	
R536	ERJ2GEJ4R7	4.7	
R537	ERJ2GEJ222	2.2k	
R538	ERJ2GEJ182	1.8k	
R541	ERJ2GEJ334	330k	
R542	ERJ2GEJ475	4.7M	
R543	ERJ2GEJ222	2.2k	
R544	ERJ2GEJ471	470	
R545	ERJ2GEJ101	100	
R546	ERJ2GEJ101	100	
R547	ERJ2GEJ101	100	
R548	ERJ2GEJ101	100	
R550	ERJ2GEJ822	8.2k	
R551	ERJ2GEJ123	12k	
R552	ERJ2GEJ102	1k	
R555	ERJ2GEJ683	68k	
R556	ERJ2GEJ105X	1M	
R557	PQ4R10XJ100	10	S
R558	ERJ2GEJ332	3.3k	
R560	ERJ2GEJ221	220	
R561	ERJ2GEJ221	220	
R562	ERJ2GEJ472X	4.7k	
R564	ERJ2GEJ223	22k	
R565	ERJ2GEJ224	220k	
R566	ERJ2GEJ224	220k	
R567	ERJ2GEJ222	2.2k	
R568	ERJ2GEJ102	1k	
R570	ERJ2GEJ684	680k	
R572	ERJ2GEJ103	10k	
R574	ERJ2GEYJ474	470k	S
R575	ERJ2GEJ103	10k	
R577	ERJ2GEJ473	47k	
R580	ERJ2GEJ473	47k	
R581	ERJ2GEJ472X	4.7k	
R583	ERJ2GEJ683	68k	
R587	ERJ2GEJ273X	27k	
R588	ERJ2GEJ333	33k	
R589	ERJ2GEJ153	15k	
R590	ERJ2GEJ392	3.9k	
R591	ERJ2GEJ182	1.8k	
R593	ERJ2GEJ224	220k	
R594	ERJ2GEJ101	100	
R595	ERJ2GEJ181	180	
R596	ERJ2GEJ103	10k	
R597	ERJ2GEJ103	10k	
R601	ERJ2GEJ473	47k	
R602	ERJ2GEJ101	100	
R603	ERJ2GEJ272	2.7k	
R604	ERJ2GEJ124	120k	

Ref. No.	Part No.	Part Name & Description	Remarks
R606	PQ4R18XJ220	22	S
R607	ERJ2GEJ124	120k	
R608	ERJ2GEJ334	330k	
R609	ERJ2GEJ473	47k	
R613	ERJ2GEJ563	56k	
R614	ERJ2GEJ682	6.8k	
R617	ERJ2GEJ473	47k	
R619	ERJ2GEJ102	1k	
R622	ERJ2GEJ332	3.3k	
R624	ERJ2GEJ472X	4.7k	
R626	ERJ2GEJ332	3.3k	
R627	ERJ2GEJ272	2.7k	
R628	ERJ2GEJ102	1k	
R630	ERJ2GEJ101	100	
R631	ERJ2GEJ101	100	
R633	ERJ2GEJ472X	4.7k	
R638	ERJ2GEJ472X	4.7k	
R506	ERJ2GEOR00	0	
R554	ERJ2GEOR00	0	
R569	ERJ2GEOR00	0	
R598	ERJ2GEOR00	0	
R618	ERJ2GEOR00	0	
R637	ERJ2GEOR00	0	
J503	ERJ2GEOR00	0	
J504	ERJ2GEOR00	0	
L504	ERJ3GEYJ103	10k	
L517	ERJ3GEYOR00	0	
L518	ERJ3GEYOR00	0	
		(COMPONENTS PARTS)	
RA501	EXB38V103JV	RESISTOR ARRAY	
RA502	EXB28V101JX	RESISTOR ARRAY	
RA503	EXB28V101JX	RESISTOR ARRAY	
RA504	D1H84724A013	RESISTOR ARRAY	S
		(CRYSTAL OSCILLATORS)	
X501	H0A327200147	CRYSTAL OSCILLATOR	
X502	H2C240500006	CRYSTAL OSCILLATOR	
X503	H0J322500006	CRYSTAL OSCILLATOR	

20.2.4. Analog Board Parts (KX-FP207FX)

Ref. No.	Part No.	Part Name & Description	Remarks
PCB2	PFLP1809SP-A	ANALOG BOARD ASS'Y (RTL)	△
		(IC)	
IC101	C0ABEB000083	IC	
		(TRANSISTORS)	
Q109	B1ABDF000026	TRANSISTOR (SI)	
Q110	B1GBCFEN0010	TRANSISTOR (SI)	
Q111	B1GBCFEN0010	TRANSISTOR (SI)	
		(DIODES)	
D101	B0EAAD000001	DIODE (SI)	
D102	B0EAAD000001	DIODE (SI)	
D104	MA4030	DIODE (SI)	S
D105	MA4030	DIODE (SI)	S
D110	MA4240	DIODE (SI)	S
D111	B0EAAD000001	DIODE (SI)	
D112	B0EAAD000001	DIODE (SI)	
DA102	B0ADEJ000026	DIODE (SI)	
		(JACKS AND CONNECTORS)	
CN101	K3E032C00040	CONNECTOR, 15 PIN	
CN102	K1KA06A00428	CONNECTOR, 6 PIN	
CN103	K2LB1YYB0002	JACK	
CN104	K2LB1YYB0002	JACK	
CN105	K1KA02A00587	CONNECTOR, 2 PIN	
		(COILS)	
L101	PQLQR2KA113	COIL	S
L102	PQLQR2KA113	COIL	S
L103	PQLQR2KA113	COIL	S

Ref. No.	Part No.	Part Name & Description	Remarks
L104	PQLQR2KA113	COIL	S
L110	PQLQR2BT	COIL	S
L111	PQLQR2BT	COIL	S
L112	PQLQR2BT	COIL	S
L113	PQLQR2BT	COIL	S
		(PHOTO ELECTRIC TRANSDUCER)	
PC103	ON3181	PHOTO COUPLER	S △
		(RELAYS)	
RLY101	K6B1CYY00005	RELAY	△
RLY102	K6B1CYY00005	RELAY	△
		(THERMISTOR)	
POS101	PFR002	POSISTOR	!S
		(TRANSFORMER)	
T101	G4AYA0000016	TRANSFORMER	△
		(VARISTORS)	
SA101	PFRZRA311P6T	VARISTOR (Surge Absorber)	S
SA102	J0LS00000024	VARISTOR (Surge Absorber)	△
		(RESISTORS)	
R102	ERJ3GEYJ103	10k	
R103	ERJ3GEYJ103	10k	
R104	ERJ3GEYJ433	43k	
R106	ERJ3GEYJ433	43k	
R107	ERJ3GEYJ220	22	
R109	ERJ3GEYJ223	22k	
R111	ERJ3GEYJ184	180k	
R112	ERJ3GEYJ223	22k	
R113	ERJ3GEYJ622	6.2k	
R120	ERDS2TJ331	330	S
R135	ERJ3GEYJ333	33k	
R136	ERJ3GEYJ394	390k	
R138	ERDS1TJ473	47k	S
R140	ERJ3GEYJ394	390k	
R143	ERJ3GEYJ203	20k	
R147	ERJ3GEYOR00	0	
R148	ERJ3GEYJ473	47k	
R149	ERJ3GEYJ331	330	
R150	ERDS1TJ333	33k	S
R151	ERJ3GEYJ562	5.6k	
R152	ERJ3GEYJ562	5.6k	
R158	ERJ3GEYJ152	1.5k	
R160	ERJ3GEYJ152	1.5k	
R161	ERJ3GEYJ331	330	
R164	ERDS2TJ101	100	S
R167	ERG2SJJ121	120	
		(CAPACITORS)	
C101	ECJ1VB1H102K	0.001	
C102	ECEA0JKA470	47	
C104	ECJ1VF1E104Z	0.1	
C105	ECJ1VB1H221K	220p	
C106	ECJ1VB1H221K	220p	
C107	ECEA0JKA470	47	
C108	ECJ1VC1H100D	10p	
C109	ECJ1VB1H682K	0.0068	
C110	ECJ1VB1E473K	0.047	
C111	ECJ1VB1H682K	0.0068	
C112	ECJ1VB1E473K	0.047	
C113	ECJ1VB1E473K	0.047	
C115	ECJ1VB1E473K	0.047	
C117	ECEA1HKS2R2	2.2	S
C118	ECJ1VB1H103K	0.01	
C127	ECJ1VB1H331K	330p	
C128	ECQE2104KF	0.1	
C131	ECJ1VC1H101J	100p	
C132	ECJ1VB1H331K	330p	
C133	ECQE2104KF	0.1	
C137	ECJ1VB1H472K	0.0047	

Ref. No.	Part No.	Part Name & Description	Remarks
C138	ECQE2474KF	0.47	
C139	ECJ1VB1C393K	0.039	
C142	ECJ1VB1C393K	0.039	
C145	ECEA0JKA470	47	
C146	ECJ1VB1H103K	0.01	
C149	ECEA0JKA470	47	
C150	ECJ1VB1H103K	0.01	
C151	ECJ1VB1H103K	0.01	
C157	ECJ1VB1H104K	0.1	

20.2.5. Analog Board Parts (KX-FP218FX)

Ref. No.	Part No.	Part Name & Description	Remarks
PCB2	PFLP1834SP-A	ANALOG BOARD ASS'Y (RTL)	△
		(ICs)	
IC101	C0ABEB000083	IC	
		(TRANSISTORS)	
Q109	B1ABDF000026	TRANSISTOR (SI)	
Q110	B1GBCFEN0010	TRANSISTOR (SI)	
Q111	B1GBCFEN0010	TRANSISTOR (SI)	
		(DIODES)	
D101	B0EAAD000001	DIODE (SI)	
D102	B0EAAD000001	DIODE (SI)	
D104	MA4030	DIODE (SI)	S
D105	MA4030	DIODE (SI)	S
D110	MA4240	DIODE (SI)	S
D111	B0EAAD000001	DIODE (SI)	
D112	B0EAAD000001	DIODE (SI)	
DA102	BOADEJ000026	DIODE (SI)	
		(CONNECTORS & JACK)	
CN101	K3E032C00040	CONNECTOR, 15 PIN	
CN102	K1KA06A00428	CONNECTOR, 6 PIN	
CN103	K2LB1YYB0002	JACK	
CN105	K1KA02A00587	CONNECTOR, 2 PIN	
		(COILS)	
L101	PQLQR2KA113	COIL	S
L102	PQLQR2KA113	COIL	S
L103	PQLQR2KA113	COIL	S
L104	PQLQR2KA113	COIL	S
L110	PQLQR2BT	COIL	S
L111	PQLQR2BT	COIL	S
		(RELAYS)	
RLY101	K6B1CYY00005	RELAY	△
RLY102	K6B1CYY00005	RELAY	△
		(THERMISTOR)	
POS101	PFRT002	POSISTOR	!S
		(PHOTO ELECTRIC TRANSDUCERS)	
PC103	0N3181	PHOTO COUPLER	S△
		(TRANSFORMER)	
T101	G4AYA0000016	TRANSFORMER	△
		(VARISTORS)	
SA101	PFRZRA311P6T	VARIATOR (Surge Absorber)	S
SA102	J0LS00000024	VARIATOR (Surge Absorber)	△
		(RESISTORS)	
R102	ERJ3GEYJ103	10k	
R103	ERJ3GEYJ103	10k	
R104	ERJ3GEYJ433	43k	
R106	ERJ3GEYJ433	43k	
R107	ERJ3GEYJ220	22	
R109	ERJ3GEYJ223	22k	

Ref. No.	Part No.	Part Name & Description	Remarks
R111	ERJ3GEYJ184	180k	
R112	ERJ3GEYJ223	22k	
R113	ERJ3GEYJ622	6.2k	
R120	ERDS2TJ331	330	S
R135	ERJ3GEYJ333	33k	
R136	ERJ3GEYJ394	390k	
R138	ERDS1TJ473	47k	S
R140	ERJ3GEYJ394	390k	
R143	ERJ3GEYJ203	20k	
R147	ERJ3GEY0R00	0	
R148	ERJ3GEYJ473	47k	
R149	ERJ3GEYJ331	330	
R150	ERDS1TJ333	33k	S
R151	ERJ3GEYJ562	5.6k	
R152	ERJ3GEYJ562	5.6k	
R158	ERJ3GEYJ152	1.5k	
R160	ERJ3GEYJ152	1.5k	
R161	ERJ3GEYJ331	330	
R164	ERDS2TJ101	100	S
R167	ERG2SJ121	120	
		(CAPACITORS)	
C101	ECJ1VB1H102K	0.001	
C102	ECEA0JKA470	47	
C104	ECJ1VF1E104Z	0.1	
C105	ECJ1VB1H221K	220p	
C106	ECJ1VB1H221K	220p	
C107	ECEA0JKA470	47	
C108	ECJ1VC1H100D	10p	
C109	ECJ1VB1H682K	0.0068	
C110	ECJ1VB1E473K	0.047	
C111	ECJ1VB1H682K	0.0068	
C112	ECJ1VB1E473K	0.047	
C113	ECJ1VB1E473K	0.047	
C115	ECJ1VB1E473K	0.047	
C117	ECEALHKS2R2	2.2	S
C118	ECJ1VB1H103K	0.01	
C127	ECJ1VB1H331K	330p	
C128	ECQE2104KF	0.1	
C131	ECJ1VC1H101J	100p	
C132	ECJ1VB1H331K	330p	
C133	ECQE2104KF	0.1	
C137	ECJ1VB1H472K	0.0047	
C138	ECQE2474KF	0.47	
C139	ECJ1VB1C393K	0.039	
C142	ECJ1VB1C393K	0.039	
C145	ECEA0JKA470	47	
C146	ECJ1VB1H103K	0.01	
C149	ECEA0JKA470	47	
C150	ECJ1VB1H103K	0.01	
C151	ECJ1VB1H103K	0.01	
C157	ECJ1VB1H104K	0.1	

20.2.6. Operation Board Parts (KX-FP207FX)

Ref. No.	Part No.	Part Name & Description	Remarks
PCB3	PFWP2FP205M	OPERATION BOARD ASS'Y (RTL)	
		(IC)	
IC301	C1ZBZ0002089	IC	
		(DIODES)	
LED301	B3AAA0000534	LED	
		(LIQUID CRYSTAL DISPLAY)	
CN302	L5DAAF000001	LIQUID CRYSTAL DISPLAY	S
		(CONNECTOR)	
CN301	K1KA08B00243	CONNECTOR, 8 PIN	

Ref. No.	Part No.	Part Name & Description	Remarks
		(SENSOR SWITCHES)	
E30	K0L1BA000126	SWITCH, SENSOR LEVER	
E31	K0L1BA000127	SWITCH, SENSOR LEVER	
		(SWITCHES)	
SW301	K0H1BA000259	SPECIAL SWITCH	
SW302	K0H1BA000259	SPECIAL SWITCH	
SW303	K0H1BA000259	SPECIAL SWITCH	
SW304	K0H1BA000259	SPECIAL SWITCH	
SW305	K0H1BA000259	SPECIAL SWITCH	
SW311	K0H1BA000259	SPECIAL SWITCH	
SW312	K0H1BA000259	SPECIAL SWITCH	
SW313	K0H1BA000259	SPECIAL SWITCH	
SW314	K0H1BA000259	SPECIAL SWITCH	
SW315	K0H1BA000259	SPECIAL SWITCH	
SW316	K0H1BA000259	SPECIAL SWITCH	
SW317	K0H1BA000259	SPECIAL SWITCH	
SW318	K0H1BA000259	SPECIAL SWITCH	
SW319	K0H1BA000259	SPECIAL SWITCH	
SW320	K0H1BA000259	SPECIAL SWITCH	
SW321	K0H1BA000259	SPECIAL SWITCH	
SW322	K0H1BA000259	SPECIAL SWITCH	
SW323	K0H1BA000259	SPECIAL SWITCH	
SW324	K0H1BA000259	SPECIAL SWITCH	
SW325	K0H1BA000259	SPECIAL SWITCH	
SW326	K0H1BA000259	SPECIAL SWITCH	
SW327	K0H1BA000259	SPECIAL SWITCH	
SW328	K0H1BA000259	SPECIAL SWITCH	
SW329	K0H1BA000259	SPECIAL SWITCH	
SW330	K0H1BA000259	SPECIAL SWITCH	
SW331	K0H1BA000259	SPECIAL SWITCH	
SW332	K0H1BA000259	SPECIAL SWITCH	
SW333	K0H1BA000259	SPECIAL SWITCH	
SW334	K0H1BA000259	SPECIAL SWITCH	
		(RESISTORS)	
R300	ERJ3GEYJ680	68	
R301	ERJ3GEYJ181	180	
R302	ERJ3GEYJ271	270	
R303	ERJ3GEYJ181	180	
R310	ERJ3GEYJ183	18k	
R311	ERJ3GEYJ122	1.2k	
R312	ERJ3GEYJ821	820	
R314	ERJ3GEYJ222	2.2k	
R315	ERJ3GEYJ4R7	4.7	
R316	ERJ3GEYJ181	180	
R320	ERJ3GEYJ331	330	
R330	ERJ3GEYJ472	4.7k	
R331	ERJ3GEYJ101	100	
R332	ERJ3GEYJ472	4.7k	
R333	ERJ3GEYJ101	100	
R341	ERJ3GEYJ332	3.3k	
R342	ERJ3GEYJ181	180	
R343	ERJ3GEYJ102	1k	
		(CAPACITORS)	
C300	ECUV1C104ZFV	0.1	
C302	ECEA0JKS101	100	S
C303	ECUV1H102KBV	0.001	
C304	ECUV1H101JCV	100P	
C305	ECUV1H331JCV	330P	
C306	ECUV1H331JCV	330P	
C307	ECUV1C104ZFV	0.1	
C308	ECUV1C104ZFV	0.1	
C310	ECUV1C104ZFV	0.1	
C311	ECUV1C104ZFV	0.1	
C330	ECUV1H103KBV	0.01	
C331	ECUV1H103KBV	0.01	
C341	ECUV1H101JCV	100P	

20.2.7. Operation Board Parts (KX-FP218FX)

Ref. No.	Part No.	Part Name & Description	Remarks
PCB3	FFWP2FP215C	OPERATION BOARD ASS'Y (RTL)	
		(IC)	
IC301	C1ZBZ0002089	IC	
		(DIODES)	
LED301	B3AAA0000534	LED	
		(LIQUID CRYSTAL DISPLAY)	
CN302	L5DAAF00001	LIQUID CRYSTAL DISPLAY	S
		(CONNECTOR)	
CN301	K1KA08B00243	CONNECTOR, 8 PIN	
		(SENSOR SWITCHES)	
E30	K0L1BA000126	SWITCH, SENSOR LEVER	
E31	K0L1BA000127	SWITCH, SENSOR LEVER	
		(SWITCHES)	
SW301	K0H1BA000259	SPECIAL SWITCH	
SW302	K0H1BA000259	SPECIAL SWITCH	
SW303	K0H1BA000259	SPECIAL SWITCH	
SW304	K0H1BA000259	SPECIAL SWITCH	
SW305	K0H1BA000259	SPECIAL SWITCH	
SW306	K0H1BA000259	SPECIAL SWITCH	
SW307	K0H1BA000259	SPECIAL SWITCH	
SW308	K0H1BA000259	SPECIAL SWITCH	
SW309	K0H1BA000259	SPECIAL SWITCH	
SW310	K0H1BA000259	SPECIAL SWITCH	
SW311	K0H1BA000259	SPECIAL SWITCH	
SW312	K0H1BA000259	SPECIAL SWITCH	
SW313	K0H1BA000259	SPECIAL SWITCH	
SW314	K0H1BA000259	SPECIAL SWITCH	
SW315	K0H1BA000259	SPECIAL SWITCH	
SW316	K0H1BA000259	SPECIAL SWITCH	
SW317	K0H1BA000259	SPECIAL SWITCH	
SW318	K0H1BA000259	SPECIAL SWITCH	
SW319	K0H1BA000259	SPECIAL SWITCH	
SW320	K0H1BA000259	SPECIAL SWITCH	
SW321	K0H1BA000259	SPECIAL SWITCH	
SW322	K0H1BA000259	SPECIAL SWITCH	
SW323	K0H1BA000259	SPECIAL SWITCH	
SW324	K0H1BA000259	SPECIAL SWITCH	
SW325	K0H1BA000259	SPECIAL SWITCH	
SW326	K0H1BA000259	SPECIAL SWITCH	
SW327	K0H1BA000259	SPECIAL SWITCH	
SW328	K0H1BA000259	SPECIAL SWITCH	
SW329	K0H1BA000259	SPECIAL SWITCH	
SW330	K0H1BA000259	SPECIAL SWITCH	
SW331	K0H1BA000259	SPECIAL SWITCH	
SW332	K0H1BA000259	SPECIAL SWITCH	
SW333	K0H1BA000259	SPECIAL SWITCH	
SW334	K0H1BA000259	SPECIAL SWITCH	
		(RESISTORS)	
R300	ERJ3GEYJ680	68	
R301	ERJ3GEYJ181	180	
R302	ERJ3GEYJ271	270	
R303	ERJ3GEYJ181	180	
R310	ERJ3GEYJ183	18k	
R311	ERJ3GEYJ122	1.2k	
R312	ERJ3GEYJ821	820	
R314	ERJ3GEYJ222	2.2k	
R315	ERJ3GEYJ4R7	4.7	
R316	ERJ3GEYJ181	180	
R320	ERJ3GEYJ331	330	
R330	ERJ3GEYJ472	4.7k	
R331	ERJ3GEYJ101	100	
R332	ERJ3GEYJ472	4.7k	

Ref. No.	Part No.	Part Name & Description	Remarks
R333	ERJ3GEYJ101	100	
R341	ERJ3GEYJ332	3.3k	
R342	ERJ3GEYJ181	180	
R343	ERJ3GEYJ102	1k	
		(CAPACITORS)	
C300	ECUV1C104ZJV	0.1	
C302	ECEA0JKS101	100	S
C303	ECUV1H102KBV	0.001	
C304	ECUV1H101JCV	100p	
C305	ECUV1H331JCV	330p	
C306	ECUV1H331JCV	330p	
C307	ECUV1C104ZJV	0.1	
C308	ECUV1C104ZJV	0.1	
C310	ECUV1C104ZJV	0.1	
C311	ECUV1C104ZJV	0.1	
C330	ECUV1H103KBV	0.01	
C331	ECUV1H103KBV	0.01	
C341	ECUV1H101JCV	100p	

20.2.8. Power Supply Board Parts

Ref. No.	Part No.	Part Name & Description	Remarks
PCB4	N0AC2GJ00006	POWER SUPPLY BOARD ASS'Y (RTL)	△
		(ICs)	
IC101	PFVIFA5518N	IC	S
IC201	TL431CDBVR	IC	
		(TRANSISTORS)	
Q101	FQPF4N90C	TRANSISTOR (SI)	△
Q203	2SC3928	TRANSISTOR (SI)	
		(DIODES)	
D101	PFVD1N4005	DIODE (SI)	S △
D102	PFVD1N4005	DIODE (SI)	S △
D103	PFVD1N4005	DIODE (SI)	S △
D104	PFVD1N4005	DIODE (SI)	S △
D105	PQVDP1007	DIODE (SI)	S
D106	PFVDD1NL20U	DIODE (SI)	S
D107	MA165	DIODE (SI)	S
D110	PFVD1N4005	DIODE (SI)	S △
D201	SF50DG	DIODE (SI)	S
D202	PFVDD1NL20U	DIODE (SI)	S
D205	MTZJ6R2B	DIODE (SI)	S
		(CONNECTOR)	
CN202	2921618	CONNECTOR, 8 PIN	S △
		(COIL)	
L101	ELF15N004A	COIL	△
		(COMPONENTS PARTS)	
L102	EXCELDR35	COMPONENTS PARTS	
		(FUSE)	
F101	PFBAST250315	FUSE	S △
		PHOTO ELECTRIC TRANSDUCER	
PC101	PFVIPC123	PHOTO COUPLER	S △
		(TRANSFORMER)	
T101	A044A2801	TRANSFORMER	S △
		(VARIABLE RESISTOR)	
VR201	EVNCYAA03B53	VARIABLE RESISTOR	S
		(VARISTOR)	
ZNR101	ERZV10D751	VARISTOR	△

Ref. No.	Part No.	Part Name & Description	Remarks
		(RESISTORS)	
JP201	ERJ3GEY0R00	0	
JP211	ERJ3GEY0R00	0	
R101	ERJ8GEYJ105	1M	
R102	ERJ8GEYJ105	1M	
R103	ERJ8GEYJ105	1M	
R104	ERJ3GEYJ473	47k	
R105	ERX2SJR22E	0.22	
R106	ERG2SJ104	100k	
R107	ERG2SJ470	47	
R110	ERDS2TJ470	47	
R111	ERDS2TJ150	15	
R112	ERJ3GEYJ101	100	
R113	ERJ3GEYJ103	10k	
R122	ERJ3GEYJ391	390	
R123	ERJ3GEYJ182	1.8k	
R201	ERDS2TJ470	47	
R202	ERJ3GEYJ223	22k	
R221	ERJ3GEYJ102	1k	
R222	ERJ3GEYJ102	1k	
R223	ERJ3GEYJ102	1k	
R224	ERJ3GEYJ562	5.6k	
R225	ERJ3GEYJ332	3.3k	
R229	ERJ3GEYJ183	18k	
R230	ERG2SJ151	150	
R231	ERG2SJ151	150	
R232	ERJ3GENF153	15k	
R233	ERJ3GENF473	47k	
R234	ERJ3GENF473	47k	
		(CAPACITORS)	
C101	ECQU2A104MLA	0.1	△
C102	ECQU2A104MLA	0.1	△
C103	DE1E102MN4AL	0.001	S △
C105	DE1E102MN4AL	0.001	S △
C106	EEUGH2W470U	47	
C108	PFKDD3AD102K	0.001	S
C109	PFKDD3DD470J	47p	S
C110	DE1E102MN4AL	0.001	S △
C111	35YXA47M71TA	47	S
C121	ECJ1VB1H472K	0.0047	
C122	ECJ1VB1A224K	0.22	
C123	ECJ1VB1H104K	0.1	
C124	ECJ1VB1H103K	0.01	
C201	KY35VB470M	470	
C205	ECJ1VB1E104K	0.1	
C211	KY10VB470M	470	
C212	PFCEA33102N2	0.001	S
C213	ECJ1VB1E104K	0.1	
C215	PFCEA33102N2	0.001	S
C217	KY25VB100M	100	
C218	ECJ1VB1H104K	0.1	

20.2.9. Interface Board Parts (KX-FP207FX)

Ref. No.	Part No.	Part Name & Description	Remarks
PCB5	PFLP1809MZ-B	INTERFACE BOARD ASS'Y (RTL)	
		(TRANSISTORS)	
Q401	B1CHR000003	TRANSISTOR (SI)	
Q402	2SB1322	TRANSISTOR (SI)	S
Q403	B1GBCFGG0028	TRANSISTOR (SI)	
IC401	B1HAGFF00015	TRANSISTOR (SI)	
		(DIODES)	
D401	B0EAD000001	DIODE (SI)	
D402	B0BA7R900004	DIODE (SI)	
D403	B0BA7R900004	DIODE (SI)	
		(CONNECTORS)	

Ref. No.	Part No.	Part Name & Description	Remarks
CN402	PQJS10A10Z	CONNECTOR, 10 PIN	S
CN403	PQJS10A10Z	CONNECTOR, 10 PIN	S
CN404	K1KA11A00158	CONNECTOR, 11 PIN	
CN405	K1KA05AA0193	CONNECTOR, 5 PIN	
CN408	K1KA02AA0193	CONNECTOR, 2 PIN	
CN409	K1KA02A00585	CONNECTOR, 2 PIN	
CN411	K1KA08A00440	CONNECTOR, 8 PIN	
		(FUSE)	
F401	K5H122200005	FUSE	
		(RESISTORS)	
R401	ERJ3GEYJ562	5.6k	
R402	ERDS1TJ152	1.5k	
R403	ERJ3GEYJ821	820	
R404	PQ4R10XJ221	220	S
R455	ERJ3GEYJ101	100	
		(CAPACITORS)	
C402	ECJ1VFLH104Z	0.1	
C403	ECJ1VFLH104Z	0.1	
C404	ECJ1VCLH101J	100p	
C405	ECJ1VCLH101J	100p	
C406	F2A1C2210033	220	
C407	ECEA1VKA330	33	

20.2.10. Interface Board Parts (KX-FP218FX)

Ref. No.	Part No.	Part Name & Description	Remarks
PCB5	PFLP1834CZ-B	INTERFACE BOARD ASS'Y (RTL)	
		(TRANSISTORS)	
Q401	B1CHRD000003	TRANSISTOR(SI)	
Q402	ZSB1322	TRANSISTOR(SI)	S
Q403	B1GBCFGG0028	TRANSISTOR(SI)	
IC401	B1HAGFF00015	TRANSISTOR(SI)	
		(DIODES)	
D401	B0EAAD000001	DIODE(SI)	
D402	B0BA7R900004	DIODE(SI)	
D403	B0BA7R900004	DIODE(SI)	
		(CONNECTORS)	
CN402	PQJS10A10Z	CONNECTOR, 10 PIN	S
CN403	PQJS10A10Z	CONNECTOR, 10 PIN	S
CN404	K1KA11A00158	CONNECTOR, 11 PIN	
CN405	K1KA05AA0193	CONNECTOR, 5 PIN	
CN408	K1KA02AA0193	CONNECTOR, 2 PIN	
CN409	K1KA02A00585	CONNECTOR, 2 PIN	
CN411	K1KA08A00440	CONNECTOR, 8 PIN	
		(FUSE)	
F401	K5H122200005	FUSE	
		(RESISTORS)	
R401	ERJ3GEYJ562	5.6k	
R402	ERDS1TJ152	1.5k	
R403	ERJ3GEYJ821	820	
R404	PQ4R10XJ221	220	S
R455	ERJ3GEYJ101	100	
		(CAPACITORS)	
C402	ECJ1VFLH104Z	0.1	
C403	ECJ1VFLH104Z	0.1	
C404	ECJ1VCLH101J	100p	
C405	ECJ1VCLH101J	100p	
C406	F2A1C2210033	220	
C407	ECEA1VKA330	33	

20.2.11. Sensor Board Parts

Ref. No.	Part No.	Part Name & Description	Remarks
PCB6	PFWP4FG2451M	SENSOR BOARD ASS'Y (RTL)	
CN1001	K1KA04B00225	CONNECTOR, 4 PIN	
SW1001	K0L2BA000001	SWITCH, SENSOR LEVER	
SW1002	K0MA11000041	REED SWITCH	

20.2.12. Film End Sensor Board Parts

Ref. No.	Part No.	Part Name & Description	Remarks
PCB7	PFWP5FG2451M	FILM END SENSOR BOARD ASS'Y (RTL)	
E70	PFJS02M17Z	CONNECTOR, 2 PIN	
SW1003	K0L1BA000111	SWITCH, SENSOR LEVER	

20.2.13. Motor Position Sensor Board Parts

Ref. No.	Part No.	Part Name & Description	Remarks
PCB8	PFWP6FG2451M	MOTOR POSITION SENSOR BOARD ASS'Y (RTL)	
E80	K0L1BA000128	SWITCH, SENSOR LEVER	
E81	PFJS02M15Z	CONNECTOR, 2 PIN	

20.2.14. Hook Switth Board Parts

Ref. No.	Part No.	Part Name & Description	Remarks
PCB9	PFLP1799MZ	HOOK SWITCH BOARD ASS'Y (RTL)	
		(JACK AND CONNECTOR)	
CN1501	K2LA1YYB0001	JACK	
CN1502	K1KA06B00185	CONNECTOR, 6 PIN	
		(SWITCH)	
SW1501	PQSH2B105Z	PUSH SWITCH	
		(COILS)	
L1501	PQLQR2KB113T	COIL	S
L1502	PQLQR2KB113T	COIL	S
L1503	PQLQR2KB113T	COIL	S
L1504	PQLQR2KB113T	COIL	S
		(RESISTORS)	
JJ1501	ERJ8GEY0R00	0	
JJ1502	ERJ8GEY0R00	0	

20.2.15. MIC Board Parts (KX-FP218FX)

Ref. No.	Part No.	Part Name & Description	Remarks
PCB10	PFWP3FP215C	MIC BOARD ASS'Y (RTL)	
MIC	WM54BY	MICROPHONE UNIT	S

20.2.16. Service Fixtures & Tools

Ref. No.	Part No.	Part Name & Description	Remarks
EC1	PFZZ11K13Z	EXTENSION CORD, 11 PIN	
EC2	PQZZ7K11Z	EXTENSION CORD, 7 PIN	
EC3	PQZZ8K15Z	EXTENSION CORD, 8 PIN	
EC4	PQZZ8K15Z	EXTENSION CORD, 8 PIN	
EC5	PQZZ2K12Z	EXTENSION CORD, 2 PIN	
EC6	PQZZ4K7Z	EXTENSION CORD, 4 PIN	
EC7	PQZZ2K12Z	EXTENSION CORD, 2 PIN	
EC8	PFZZ5K13Z	EXTENSION CORD, 5 PIN	
EC9	PQZZ2K6Z	EXTENSION CORD, 2 PIN	
EC10	PFZZ15K1Z	EXTENSION CORD, 15 PIN	
EC11	PFZZ10K3Z	EXTENSION CORD, 10 PIN	
EC12	PFZZ10K3Z	EXTENSION CORD, 10 PIN	
EC13	PQZZ2K12Z	EXTENSION CORD, 2 PIN (KX-FP218)	
	KM79811245C0	BASIC FACSIMILE TECHNIQUE (for training service technicians)	

Note:

Tools and Extension Cords are useful for servicing.
(They make servicing easy.)

Y.F
KXFP207FX-S
KXFP218FX-S